Installation Guide

HP 8702D Lightwave Component Analyzer



© Copyright Hewlett-Packard Company 1998
All Rights Reserved. Reproduction, adaptation, or translation without prior written permission is prohibited, except as allowed under copyright laws.

HP Part No. 08702-90051
Printed in USA
February 1998

Hewlett-Packard Company
Lightwave Operations
1400 Fountaingrove Parkway
Santa Rosa, CA 95403-1799,
USA
(707) 577-1400

Notice.

The information contained in this document is subject to change without notice. Companies, names, and data used in examples herein are fictitious unless otherwise noted. Hewlett-Packard makes no warranty of any kind with regard to this material, including but not limited to, the implied warranties of merchantability and fitness for a particular purpose. Hewlett-Packard shall not be liable for errors contained herein or for incidental or consequential damages in connection with the furnishing, performance, or use of this material.

Restricted Rights Legend.

Use, duplication, or disclosure by the U.S. Government is subject to restrictions as set forth in subparagraph (c) (1) (ii) of the Rights in Technical Data and Computer Software clause at DFARS 252.227-7013 for DOD agencies, and subparagraphs (c) (1) and (c) (2) of the Commercial Computer Software Restricted Rights clause at FAR 52.227-19 for other agencies.

Warranty.

This Hewlett-Packard instrument product is warranted against defects in material and workmanship for a period of one year from date of shipment. During the warranty period, Hewlett-Packard Company will, at its option, either repair or replace products which prove to be defective. For warranty service or repair, this product must be returned to a service facility designated by Hewlett-Packard. Buyer shall prepay shipping charges to Hewlett-Packard and Hewlett-Packard shall pay shipping charges to return the product to Buyer. However, Buyer shall pay all shipping charges, duties, and taxes for products returned to Hewlett-Packard from another country.

Hewlett-Packard warrants that its software and firmware designated by Hewlett-Packard for use with an instrument will execute its programming instructions when properly installed on that instrument. Hewlett-Packard does not warrant that the operation of the instrument, or software, or firmware will be uninterrupted or error-free.

Limitation of Warranty.

The foregoing warranty shall not apply to defects resulting from improper or inadequate maintenance by Buyer, Buyer-supplied software or interfacing, unauthorized modification or misuse, operation outside of the environmental specifications for the product, or improper site preparation or maintenance.

No other warranty is expressed or implied. Hewlett-Packard specifically

disclaims the implied warranties of merchantability and fitness for a particular purpose.

Exclusive Remedies.

The remedies provided herein are buyer's sole and exclusive remedies. Hewlett-Packard shall not be liable for any direct, indirect, special, incidental, or consequential damages, whether based on contract, tort, or any other legal theory.

Safety Symbols.

CAUTION

The *caution* sign denotes a hazard. It calls attention to a procedure which, if not correctly performed or adhered to, could result in damage to or destruction of the product. Do not proceed beyond a caution sign until the indicated conditions are fully understood and met.

WARNING

The *warning* sign denotes a hazard. It calls attention to a procedure which, if not correctly performed or adhered to, could result in injury or loss of life. Do not proceed beyond a warning sign until the indicated conditions are fully understood and met.



The instruction manual symbol. The product is marked with this warning symbol when it is necessary for the user to refer to the instructions in the manual.



The laser radiation symbol. This warning symbol is marked on products which have a laser output.



The AC symbol is used to indicate the required nature of the line module input power.



The ON symbols are used to mark the positions of the instrument power line switch.



The OFF symbols are used to mark the positions of the instrument power line switch.



The CE mark is a registered trademark of the European Community.



The CSA mark is a registered trademark of the Canadian Standards Association.

ISM1 A

This text denotes the instrument is an Industrial Scientific and Medical Group 1 Class A product.

Typographical Conventions.

The following conventions are used in this book:

Key type for keys or text located on the keyboard or instrument.

Softkey type for key names that are displayed on the instrument's screen.

Display type for words or characters displayed on the computer's screen or instrument's display.

User type for words or characters that you type or enter.

Emphasis type for words or characters that emphasize some point or that are used as place holders for text that you type.

Installation at a Glance

The procedures in this book provide step-by-step instructions for installing the HP 8702D.

Be sure to verify the HP 8702D's performance

Chapter 2, "Automated Verification", Chapter 3, "Manual Verification", and Chapter 4, "Performance Tests" provide verification procedures and performance tests. Verification procedures are intended to provide a high level of confidence that the instrument is operating properly. Two versions of verification procedures are provided: automated and manual. The performance tests, along with the verification tests, provide the same quality of performance testing that is done at the factory. Chapter 5, "Automated Verification – Option 011" and Chapter 6, "Performance Tests – Option 011" provide verification procedures and performance tests for the HP 8702D Option 011.

Hewlett-Packard recommends that you verify your analyzer measurement system every six months. Hewlett-Packard also suggests that you get your verification kit recertified annually. Refer to *HP 85029B 7 mm Verification Kit Operating and Service Manual* for more information.

These system verification procedures do *not* apply to analyzers with Option 075 (75 ohm analyzers).

General Safety Considerations

This product has been designed and tested in accordance with IEC Publication 1010, Safety Requirements for Electronic Measuring Apparatus, and has been supplied in a safe condition. The instruction documentation contains information and warnings which must be followed by the user to ensure safe operation and to maintain the product in a safe condition.

WARNING

If this product is not used as specified, the protection provided by the equipment could be impaired. This product must be used in a normal condition (in which all means for protection are intact) only.

WARNING

No operator serviceable parts inside. Refer servicing to qualified personnel. To prevent electrical shock, do not remove covers.

Certification

Hewlett-Packard Company certifies that this product met its published specifications at the time of shipment from the factory. Hewlett-Packard further certifies that its calibration measurements are traceable to the United States National Institute of Standards and Technology, to the extent allowed by the Institute's calibration facility, and to the calibration facilities of other International Standards Organization members.

Assistance

Product maintenance agreements and other customer assistance agreements are available for Hewlett-Packard products. For any assistance, contact your nearest Hewlett-Packard Sales and Service Office.

Contents

1 Installing the HP 8702D

- Step 1. Inspect the Shipment 1-4
- Step 2. Set up Static-Safe Workstation 1-5
- Step 3. Option 1D5, Connect the Frequency Reference 1-7
- Step 4. Check the Fuse and Voltage Selection 1-8
- Step 5. Connect the Line-Power Cable 1-10
- Step 6. Connect a Keyboard 1-11
- Step 7. Turn on the HP 8702D 1-12
- Step 8. Connect a Printer or Plotter 1-13
- Step 9. If You Connect a Printer 1-14
- Step 10. If You Connect a Plotter 1-15
- Step 11. Set the Clock 1-16
- Step 12. Check the Operation 1-17
- Step 13. Check the Operation (Option 011) 1-22
- Step 14. Copy the EEPROM Disk 1-27

2 Automated Verification

- Step 1. Initialization 2-4
- Step 2. Measurement Calibration 2-5
- Step 3. Device Verification 2-7
- In Case of Difficulty 2-10

3 Manual Verification

- Step 1. Initialization 3-3
- Step 2. Measurement Calibration 3-5
- Step 3. Device Verification 3-7
- In Case of Difficulty 3-11

4 Performance Tests

- 1. Test Port Output Frequency Range and Accuracy 4-4
- 2. External Source Mode Frequency Range 4-6
- 3. Test Port Output Power Accuracy 4-8
- 4. Test Port Output Power Range and Linearity 4-11
- 5. Minimum R Channel Level 4-14
- 6. Test Port Input Noise Floor Level 4-19
- 7. Test Port Input Frequency Response 4-23
- 8. Test Port Crosstalk 4-34

Contents

- 9. Calibration Coefficients 4-39
 - 10. System Trace Noise (Only for Analyzers without Option 006) 4-46
 - 11. System Trace Noise (Only for Analyzers with Option 006) 4-48
 - 12. Test Port Input Impedance 4-51
 - 13. Test Port Receiver Magnitude Dynamic Accuracy 4-55
 - 14. Test Port Receiver Phase Dynamic Accuracy 4-63
 - 15. Test Port Receiver Magnitude Compression 4-65
 - 16. Test Port Receiver Phase Compression 4-68
 - 17. Test Port Output/Input Harmonics (Option 002 Analyzers without Option 006 Only) 4-71
 - 18. Test Port Output/Input Harmonics (Option 002 Analyzers with Option 006 Only) 4-76
 - Performance Test Records 4-81
- 5 Automated Verification – Option 011**
- HP 8702D Option 011 and HP 85046A/47A System Verification 5-4
 - Step 1. Initialization 5-5
 - Step 2. Measurement Calibration 5-7
 - Step 3. Device Verification 5-10
 - In Case of Difficulty 5-14
 - HP 8702D Option 011 and HP 85044A System Verification 5-15
 - Step 1. Initialization 5-16
 - Step 2. Measurement Calibration 5-17
 - Step 3. Device Verification 5-19
 - In Case of Difficulty 5-23
- 6 Performance Tests – Option 011**
- 1. Source Frequency Range and Accuracy 6-4
 - 2. Source Power Range, Linearity, and Accuracy 6-6
 - 3. Receiver Minimum R Channel Level 6-12
 - 4. Receiver Minimum R Channel Level for External Source Mode 6-15
 - 5. Receiver Channel Noise Floor Level (Only for Analyzers without Option 006) 6-18
 - 6. Receiver Channel Noise Floor Level (Only for Analyzers with Option 006) 6-21
 - 7. Receiver Magnitude Frequency Response 6-25
 - 8. Receiver Phase Frequency Response 6-29

Contents

- 9. Receiver Input Crosstalk 6-32
- 10. Receiver Trace Noise 6-38
- 11. Receiver Input Impedance 6-40
- 12. Receiver Magnitude Dynamic Accuracy 6-45
- 13. Receiver Phase Dynamic Accuracy 6-53
- 14. Receiver Magnitude Compression 6-55
- 15. Receiver Phase Compression 6-63
- 16. Source and Receiver Harmonics (Option 002 Only) 6-70
- 17. Receiver Magnitude Frequency Response
(Option 002 Only) 6-75
- Performance Test Records - Option 011 6-78

7 If You Encounter a Problem

- If the display does not light 7-4
- If the fan does not run 7-5
- If data entry keys don't respond 7-6
- If there is no RF signal 7-7
- Returning the Instrument for Service 7-8
- Hewlett-Packard Sales and Service Offices 7-11

Contents

Installing the HP 8702D

Installing the HP 8702D

The instructions in this chapter show you how to install your HP 8702D. You should be able to finish these procedures in about ten to twenty minutes.

Refer to “Specifications and Regulatory Information”, in the *HP 8702D Reference* manual, for information on operating conditions such as temperature.

If you should ever need to clean the cabinet, use a damp cloth only.

WARNING

Any interruption of the protective conductor inside or outside of the product is likely to make the product dangerous. Intentional interruption is prohibited.

CAUTION

This product has autoranging line voltage input. Be sure the supply voltage is within the specified range.

CAUTION

VENTILATION REQUIREMENTS: When installing the product in a cabinet, the convection into and out of the product must not be restricted. The ambient temperature (outside the cabinet) must be less than the maximum operating temperature of the product by 4°C for every 100 watts dissipated in the cabinet. If the total power dissipated in the cabinet is greater than 800 watts, then forced convection must be used.

CAUTION

This product is designed for use in INSTALLATION CATEGORY II and POLLUTION DEGREE 2, per IEC 1010 and 664 respectively.

What you'll find in this chapter

- Step 1. Inspect the Shipment 1-4
- Step 2. Set up Static-Safe Workstation 1-5
- Step 3. Option 1D5, Connect the Frequency Reference 1-7
- Step 4. Check the Fuse and Voltage Selection 1-8
- Step 5. Connect the Line-Power Cable 1-10
- Step 6. Connect a Keyboard 1-11
- Step 7. Turn on the HP 8702D 1-12
- Step 8. Connect a Printer or Plotter 1-13
- Step 9. If You Connect a Printer 1-14
- Step 10. If You Connect a Plotter 1-15
- Step 11. Set the Clock 1-16
- Step 12. Check the Operation 1-17
- Step 13. Check the Operation (Option 011) 1-22
- Step 14. Copy the EEPROM Disk 1-27

Step 1. Inspect the Shipment

Step 1. Inspect the Shipment

- 1 Verify that all components ordered have arrived by comparing the shipping forms to the original purchase order. Inspect all shipping containers.

If your shipment is damaged or incomplete, save the packing materials and notify both the shipping carrier and the nearest Hewlett-Packard sales and service office. HP will arrange for repair or replacement of damaged or incomplete shipments without waiting for a settlement from the transportation company. Notify the HP customer engineer of any problems.

WARNING

The HP 8702D weighs approximately 75 pounds (34 kilograms). Use correct lifting techniques.

The PORT 1 connector moves.

This is *not* a defect. This connector is designed to move so that test sets and other accessories can be more easily connected to the instrument.

- 2 Make sure that the serial number and options listed on the instrument's rear-panel label match the serial number and options listed on the shipping document.

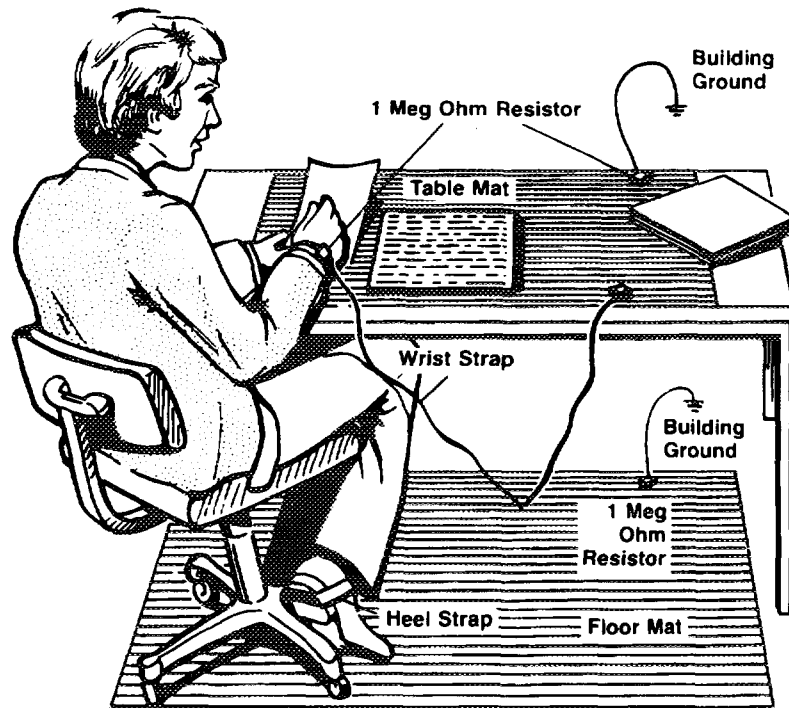

Figure 1-1. Serial Number Label

Step 2. Set up Static-Safe Workstation

Electrostatic discharge (ESD) can damage or destroy the input circuits of the HP 8702D. ESD can also damage or destroy electronic components that you are measuring. All work should be performed at a static-safe work station. The following figure shows an example of a static-safe work station (without the instrument) using two types of ESD protection:

- Conductive table-mat and wrist-strap combination.
- Conductive floor-mat and heel-strap combination.



Step 2. Set up Static-Safe Workstation

Both types, when used together, provide a significant level of ESD protection. Of the two, only the table-mat and wrist-strap combination provides adequate ESD protection when used alone.

To ensure user safety, the static-safe accessories must provide at least 1 M Ω of isolation from ground. Refer to Table 1-1 for information on ordering static-safe accessories.

WARNING

These techniques for a static-safe work station should not be used when working on circuitry with a voltage potential greater than 500 volts.

Reducing ESD Damage

The following suggestions may help reduce ESD damage that occurs during testing and servicing operations.

- Personnel should be grounded with a resistor-isolated wrist strap before removing any assembly from the unit.
- Be sure all instruments are properly earth-grounded to prevent a buildup of static charge.

Table 1-1. Static-Safe Accessories

HP Part Number	Description
9300-0797	3M static control mat 0.6 m \times 1.2 m (2 ft \times 4 ft) and 4.6 cm (15 ft) ground wire. (The wrist-strap and wrist-strap cord are not included. They must be ordered separately.)
9300-0980	Wrist-strap cord 1.5 m (5 ft)
9300-1383	Wrist-strap, color black, stainless steel, without cord, has four adjustable links and a 7 mm post-type connection.
9300-1169	ESD heel-strap (reusable 6 to 12 months)

Step 3. Option 1D5, Connect the Frequency Reference

If your instrument has the optional high stability frequency reference installed, connect the jumper cable on the HP 8702D rear panel as shown in Figure 1-2.

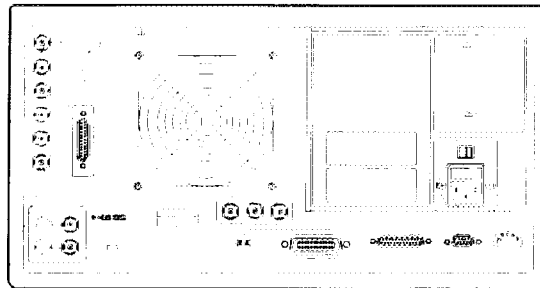

Figure 1-2. Jumper Cable Connection

Step 4. Check the Fuse and Voltage Selection

- 1 Locate the line-input connector on the instrument's rear panel.
- 2 Disconnect the line-power cable if it is connected.
- 3 Use a small flat-blade screwdriver to open the pull-out fuse drawer.

WARNING

The power cord is connected to internal capacitors that may remain live for 10 seconds after you disconnect the cord from the power supply.

Figure 1-3. Line Fuse Removal and Replacement

- 4 Verify that the value of the line-voltage fuse in the pull-out drawer is correct. The recommended fuse is an IEC 127 5×20 mm, 3A, 250 V, HP part number 2110-0780.

Notice that an extra fuse is provided in a drawer located on the fuse holder.

Step 4. Check the Fuse and Voltage Selection**WARNING**

For continued protection against fire hazard, replace line fuse only with same type and ratings, (type T 3A/250V for 100/240V operation). The use of other fuses or materials is prohibited.

- 5 Set the rear panel line-voltage selector to the position that corresponds to the AC power source. Refer to Figure 1-4.

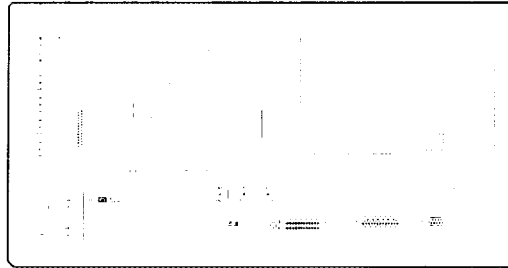

Figure 1-4. Line Voltage Selector

Table 1-2. Line Power Requirements

Power:	115 VAC: 50 WATTS MAX. 230 VAC: 50 WATTS MAX.
Voltage	nominal: 115 VAC / 230 VAC range 115 VAC: 90–132 V range 230 VAC: 198–254 V
Frequency	nominals: 50 Hz / 60 Hz range: 47–63 Hz

Step 5. Connect the Line-Power Cable

Step 5. Connect the Line-Power Cable

CAUTION

Always use the three-prong AC power cord supplied with this instrument. Failure to ensure adequate earth grounding by not using this cord may cause instrument damage.

CAUTION

Do *not* connect ac power until you have verified the line voltage is correct as described in the following paragraphs. Damage to the equipment could result.

- 1 Connect the line-power cord to the instrument's rear-panel connector. Refer to Figure 1-5.
- 2 Connect the other end of the line-power cord to the power receptacle. Refer to Figure 1-5.

Various power cables are available to connect the HP 8702D to ac power outlets unique to specific geographic areas. The cable appropriate for the area to which the HP 8702D is originally shipped is included with the unit. You can order additional ac power cables for use in different geographic areas. Refer to the *HP 8702D Reference* manual for a list of available power cables.

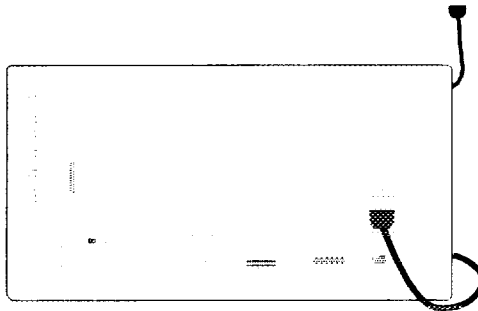

Figure 1-5. Power Cord Connection

Step 6. Connect a Keyboard

- If you plan to use a keyboard with your HP 8702D, connect it now to the instrument's rear-panel keyboard connector.

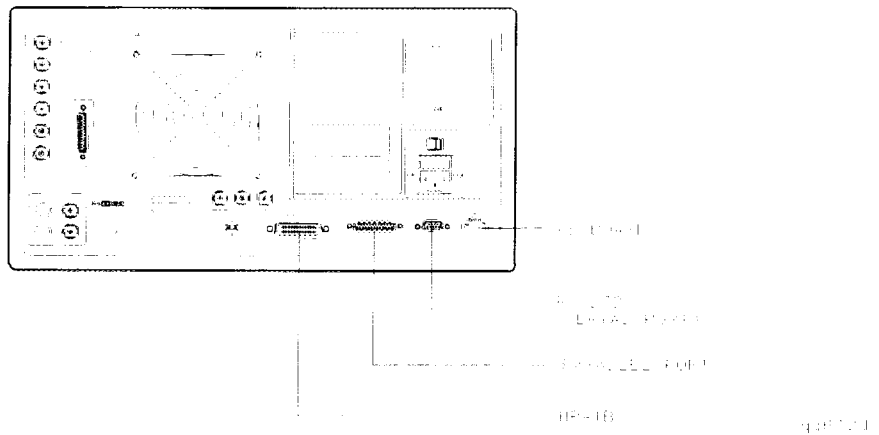

Figure 1-6. Rear Panel Peripheral Connections

Step 7. Turn on the HP 8702D

- 1 Press the front-panel LINE key. Refer to Figure 1-7.

The front-panel LINE switch disconnects the mains circuits from the mains supply after the EMC filters and before other parts of the instrument.

- 2 If the HP 8702D fails to turn on properly, consider the following possibilities:

- Is the line fuse good?
- Does the line socket have power?
- Is it plugged into the proper ac power source?

If the instrument still fails, return it to Hewlett-Packard for repair. Refer to "Returning the Instrument for Service" on page 7-8.

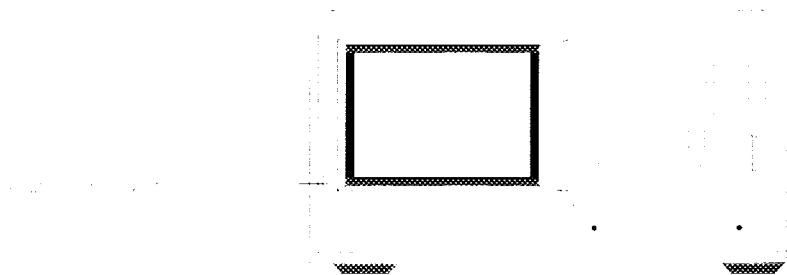

Figure 1-7. Turning on the Instrument

Step 8. Connect a Printer or Plotter

- 1 Connect a printer or plotter to the corresponding interface port. Refer to Figure 1-6 on page 1-11 for the appropriate rear panel connection.

Printer Interface	Recommended Cable
Parallel	HP 92284A
Serial	HP 24542G
HP-IB	HP 10833A/B/D

- 2 If you are using the parallel interface, press **LOCAL** and then *PARALLEL* until *COPY* appears.

The *GPIO* selection dedicates the parallel port for general purpose I/O. The HP 8702D controls the data input or output through the sequencing capability of the instrument.

- 3 If you are using an HP-IB printer or plotter, press **LOCAL**, *SYSTEM CONTROLLER* to set up the HP 8702D as the controller.

Step 9. If You Connect a Printer

- 1** Press *LOCAL*, *SET ADDRESSES*, *PRINTER PORT*.
- 2** Press the key that corresponds to the printer interface: *HPIB*, *PARALLEL* (parallel port), or *SERIAL* (serial port).
- 3** If you selected *HPIB*, the HP-IB address is active so you can then set the address of your printer. The default HP-IB printer address is 1.
- 4** If you select *SERIAL*, adjust the HP 8702D's baud rate and handshaking protocol:
 - a** Press *PRINTER BAUD RATE*, and use the up and down arrow front-panel keys to select the baud rate.
 - b** Set the transmission control, *XMIT CNTRL* (handshaking protocol) to either *XON/XOFF* or *DTR/DSR* (equal to the transmission control set on the peripheral).

XON/XOFF selects software handshaking. *DTR/DSR* selects hardware handshaking. Consult the printer's manual for the proper settings.
- 5** Press *PRNTR TYPE* until the correct printer choice appears:
 - *ThinkJet* (QuietJet)
 - *DeskJet* (except for HP DeskJet 540)
 - *LaserJet*
 - *PaintJet*
 - *Epson-P2* (printers that conform to the ESC.P2 printer control language)
 - *DJ540* (converts 100 dpi raster information to 300 dpi raster format)

Step 10. If You Connect a Plotter

- 1** Press *LOCAL*, *SET ADDRESSES*, *PLOTTER PORT*.
- 2** Press the key that corresponds to the plotter interface: *HPIB*, *PARALLEL* (parallel port), or *SERIAL* (serial port).
- 3** If you selected *HPIB*, the HP-IB address is active so you can then set the address of your plotter. The default HP-IB plotter address is 5.
- 4** If you select *SERIAL*, adjust the HP 8702D's baud rate and handshaking protocol:
 - a** Press *PLOTTER BAUD RATE*, and use the up and down arrow front-panel keys to select the baud rate.
 - b** Set the transmission control, *XMIT CNTRL* (handshaking protocol) to either *XON/XOFF* or *DTR/DSR* (equal to the transmission control set on the peripheral).

XON/XOFF selects software handshaking. *DTR/DSR* selects hardware handshaking. Consult the printer's manual for the proper settings.
- 5** Press *PLTR TYPE* until the correct plotter selection appears:
 - Choose *PLTR TYPE [PLOTTER]* if you will be using a plotter to make your hardcopy.
 - Choose *PLTR TYPE [HPGL PRT]* if you will be using an HPGL compatible printer to make your hardcopy.

Step 11. Set the Clock

- 1 Press **SYSTEM**, *SET CLOCK* to begin setting and activating the time stamp feature so the *HP 8702D* places the time and date on your hardcopies and disk directories.
- 2 Press the appropriate softkey to set the time and date.
- 3 Press *ROUND SECONDS* when the time is exactly as you have set it.
- 4 Press *TIME STAMP* so that *ON* is displayed on the softkey label. Then, press *RETURN*.



Figure 1-8. Setting the Clock

Step 12. Check the Operation

If your instrument is an HP 8702D Option 011, skip this step and continue with “Step 13. Check the Operation (Option 011)” on page 1-22.

- 1 Turn off the LINE power switch. Then, turn back on the LINE power switch.
- 2 Locate the serial number and configuration options shown on the display. Compare them to the shipment documents.
- 3 Press PRESET, and observe items shown in Figure 1-9.

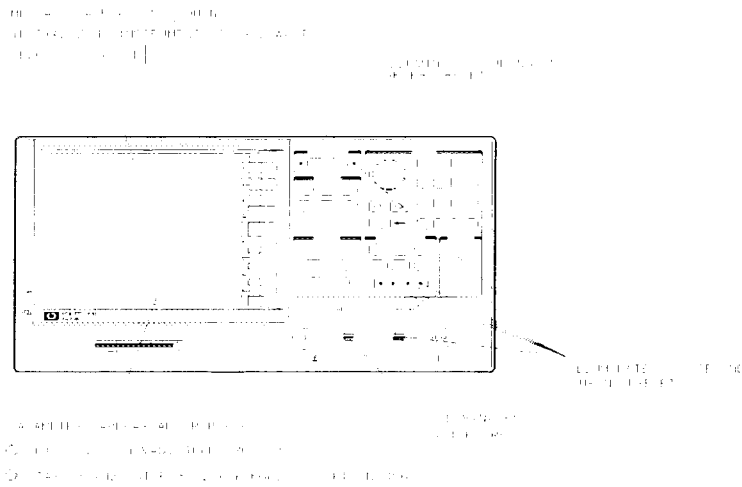

Figure 1-9. Checking the Operation

- 4 Connect the equipment as shown in Figure 1-10.

Step 12. Check the Operation



Figure 1-10. Operation Check Connections

- 5** Press PRESET, SYSTEM, *SERVICE MENU*, TESTS, EXTERNAL TESTS, EXECUTE TEST.
- 6** Follow the prompts shown on the display, and then press *CONTINUE*.
- 7** Press the up-arrow key, *EXECUTE TEST*, and then follow the prompts shown on the display. Then press *CONTINUE*.
- 8** Connect the equipment as shown in Figure 1-11 and press PRESET.

The test port return cable should have low-loss characteristics to avoid a degradation in frequency response at higher frequencies.

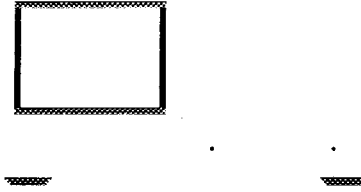
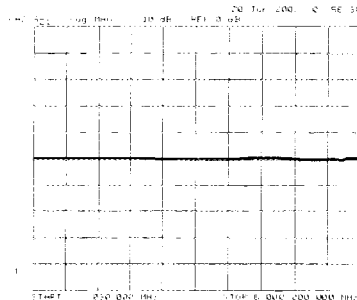

Figure 1-11. Transmission Mode Connections

- 9 Press CHAN2 to check the forward transmission mode for channel 2. Look at the measurement trace displayed on the HP 8702D. It should be similar to the trace shown in Figure 1-12.

The HP 8702D display shown in Figure 1-12 and Figure 1-13 are HP 8702D Option 006 displays (30 kHz to 6 GHz span).



catch2_c.tif

Figure 1-12. Forward Transmission Display

- 10 Press MEAS and then *Trans: E/E S12 REV* to check the reverse transmission mode for channel 2. The measurement trace should be similar to the trace shown in Figure 1-13.

Step 12. Check the Operation

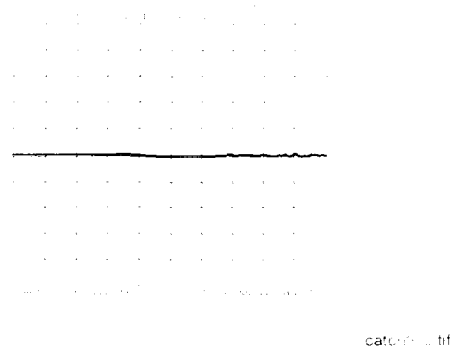

Figure 1-13. Reverse Transmission Display

- 11 Connect the equipment as shown in Figure 1-14 and press PRESET.

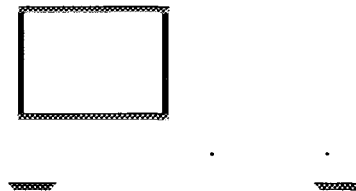

Figure 1-14. Transmission Load Match Connections

- 12 Look at the measurement trace displayed on the HP 8702D. It should be similar to the trace displayed in Figure 1-15.

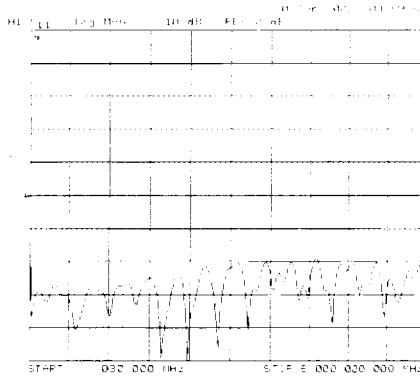

Figure 1-15. Forward Transmission Mode

- 13** Press MEAS, Refl: E S22 REV to check the reverse reflection mode for channel 1. The measurement trace should be similar to Figure 1-16.

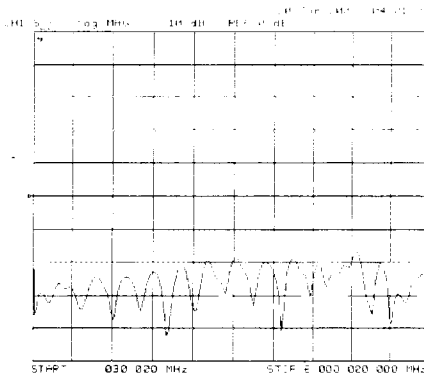

Figure 1-16. Reverse Reflection Mode

- 14** Continual with "Step 14. Copy the EEPROM Disk" on page 1-27.

Step 13. Check the Operation (Option 011)

Step 13. Check the Operation (Option 011)

An HP 85047A S-parameter test set must be used when making measurements.

- 1 Turn off the LINE power switch. Then, turn back on the LINE power switch.
- 2 Locate the serial number and configuration options shown on the display. Compare them to the shipment documents.
- 3 Press PRESET, and observe that the analyzer is operating properly as shown in Figure 1-17.

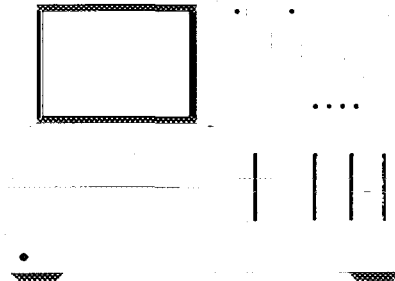

Figure 1-17. Checking the Operation (Option 011)

- 4 Connect the equipment as shown in Figure 1-18.

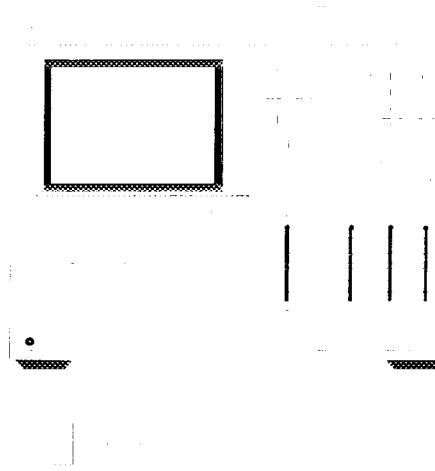

Figure 1-18. Operation Check Connections

- 5** Press *PRESET*, *SYSTEM*, *SERVICE MENU*, *TESTS*, *EXTERNAL TESTS*, *EXECUTE TEST*.
- 6** Follow the prompts shown on the display, and then press *CONTINUE*.
- 7** Press the up-arrow key, *EXECUTE TEST*, and then follow the prompts shown on the display. Then press *CONTINUE*.
- 8** Connect the equipment as shown in Figure 1-19 and press *PRESET*.

The test port return cable should have low-loss characteristics to avoid a degradation in frequency response at higher frequencies.

Step 13. Check the Operation (Option 011)

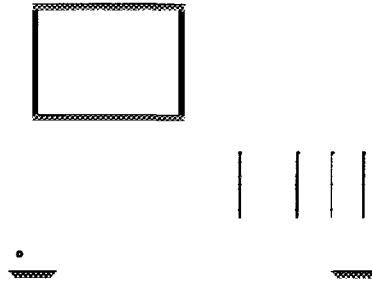

Figure 1-19. Transmission Mode Connections

- 9 Press CH2 to check the forward transmission mode for channel 2. Look at the measurement trace displayed on the analyzer. It should be similar to the trace shown in Figure 1-20.

The analyzer display shown in Figure 1-20 and Figure 1-21 are HP 8702D Option 011, Option 006 displays (30 kHz to 6 GHz span).

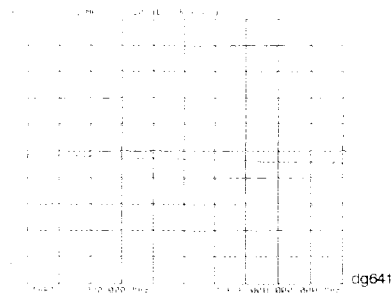

Figure 1-20. Forward Transmission Display

Step 13. Check the Operation (Option 011)

- 10** Press MEAS and then *Trans: E/E S12 REV* to check the reverse transmission mode for channel 2. The measurement trace should be similar to the trace shown in Figure 1-21.

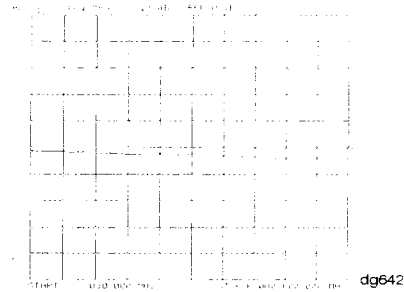

Figure 1-21. Reverse Transmission Display

- 11** Connect the equipment as shown in Figure 1-22 and press PRESET.

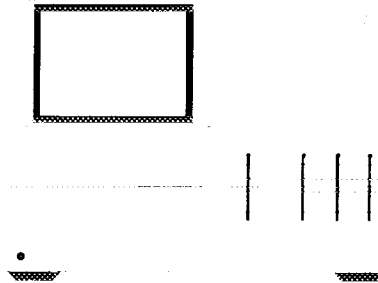

Figure 1-22. Transmission Load Match Connections

Step 13. Check the Operation (Option 011)

- 12 Look at the measurement trace displayed on the analyzer. It should be similar to the trace displayed in Figure 1-23.

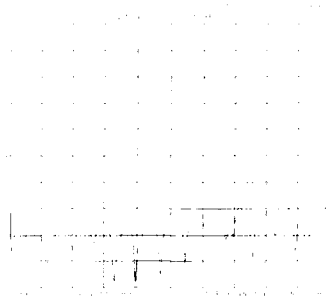

Figure 1-23. Forward Transmission Mode

- 13 Press MEAS, *Ref: E S22 REV* to check the reverse reflection mode for channel 1. The measurement trace should be similar to Figure 1-24.

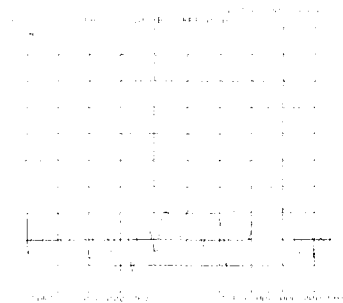

Figure 1-24. Reverse Reflection Mode

Step 14. Copy the EEPROM Disk

The HP 8702D is shipped from the factory with an EEPROM backup disk which is unique to each instrument. The backup disk contains a copy of correction constants which were stored in the instrument's internal memory at the factory. If your HP 8702D should ever be damaged, these correction constants may need to be reinstalled from the disk. Use the following procedure to create a backup copy of the disk.

The disks can be ordered as HP 92192A (box of 10).

- 1** Insert a 3.5-inch disk into the HP 8702D's disk drive.
- 2** Press PRESET so that the preset state is stored.
- 3** If the disk is not formatted, press SAVE/RECALL, *FILE UTILITIES*, *FORMAT DISK*.
 - To format a LIF disk, select *FORMAT:LIF* (The supplied EEPROM backup disk is LIF. The HP 8702D does not support LIF-HFS format.)
 - To format a DOS disk, select *FORMAT:DOS*.

Press *FORMAT INT DISK*, and answer *YES* at the query.

- 4** Press SYSTEM, *SERVICE MENU*, *SERVICE MODES*, *MORE*, *STORE EEPR ON*, SAVE/RECALL, *SAVE RCL MENU*, *SELECT DISK*, *INTERNAL DISK*, RETURN, *SAVE STATE* to store the correction-constants data onto floppy disk.

A default file "FILE0" is created. The file name appears in the upper left-hand corner of the display. The file type "ISTATE(E)" describes the file as an instrument-state with EEPROM backup.

- 5** Press *FILE UTILITIES*, *RENAME FILE*, *ERASE TITLE*. Use the RPG and the *SELECT LETTER* softkey to rename the file "FILE0" to "N12345" where 12345 represents the last 5 digits of the instrument's serial number. (The first character in the file name must be a letter.) When finished, press *DONE*.
- 6** Label the disk with the serial number of the instrument and the words "EEPROM Backup Disk".

Whenever the HP 8702D is returned to Hewlett-Packard for servicing and/or calibration, the EEPROM backup disk should be returned with the HP 8702D. This will significantly reduce the instrument repair time. The EEPROM backup disk procedure is now complete.

Installing the HP 8702D

Step 14. Copy the EEPROM Disk

Automated Verification

Automated Performance Verification

The automated performance verification procedure in this chapter provide a high level of confidence that the HP 8702D is working properly. Although this procedure is automated, it does *not* require a computer. However, you'll need to locate the *Verification Data Disk*. If you cannot locate the disk, perform the manual version located in Chapter 3, "Manual Verification". If you are using an HP 8702D Option 011, refer to Chapter 5, "Automated Verification – Option 011".

Allow the HP 8702D to warm up for one hour before starting this procedure.

In order to run this procedure, the following equipment is required:

Calibration Kit, 7 mm	HP 85031B
Verification Kit, 7 mm	HP 85029B Option 001
Test Port Extension Cable Set, 7 mm	HP 11857D
Printer	HP ThinkJet/DeskJet/LaserJet

Hewlett-Packard recommends that you verify your analyzer measurement system every six months. Hewlett-Packard also suggests that you get your verification kit recertified annually. Refer to the *HP 85029B Option 001 7 mm Verification Kit Operating and Service Manual* for more information.

<p>NOTE</p> <p>The system verification procedures do <i>not</i> apply to analyzers with Option 075 (75 Ω).</p>

<p>HP 8753D is shown in the figures</p> <p>The procedures in this chapter are designed to work with HP 8702D and HP 8753D instruments. Because of this, many of the figures label the instrument being tested as an HP 8753D. Simply substitute your HP 8702D for the HP 8753D.</p>

How to select the system verification procedure

Check to see how the verification kit floppy disk is labeled:

- If the disk is labeled Verification Data Disk, proceed with the HP 8702D Automated Mode System Verification in this chapter.
- If the disk is labeled Verification Data Disc, proceed with the HP 8702D Manual Mode System Verification procedure, located in Chapter 3, "Manual Verification".

NOTE

If your verification disk is older than your HP 8702D, you may send your HP 85029B Option 001 7 mm verification kit to the nearest service center for recertification, which includes a data disk that you can use with the HP 8702D.

What you'll find in this chapter

- Step 1. Initialization 2-4
- Step 2. Measurement Calibration 2-5
- Step 3. Device Verification 2-7
- In Case of Difficulty 2-10

Step 1. Initialization

Step 1. Initialization

- 1 Connect the equipment as shown in Figure 2-1. Let the HP 8702D warm up for one hour.

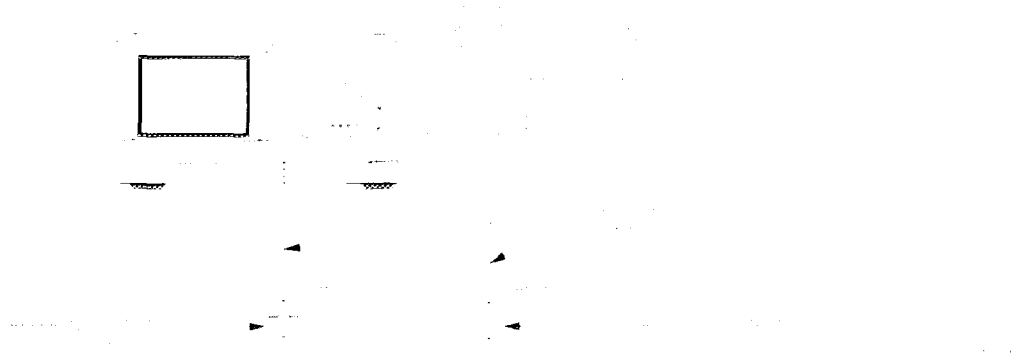

Figure 2-1. System Verification Test Setup

- 2 While the equipment is warming up, review the connector care information in the *HP 8702D User's Guide*.
- 3 Insert the verification kit disk into the HP 8702D's disk drive.
- 4 Press PRESET, SAVE/RECALL, *SELECT DISK*, *INTERNAL DISK*.
- 5 If you want a printout of the verification data for all the devices, press SYSTEM, *SERVICE MENU*, *TEST OPTIONS*, *RECORD ON*.

If you switch on the record function, you *cannot* switch it off during the verification procedure.

- 6 Position the paper in the printer so that printing starts at the top of the page.
- 7 Press SYSTEM, *SERVICE MENU*, *TESTS*, *SYS VER TESTS*, *EXECUTE TEST*.
- 8 When the HP 8702D displays, Sys Ver Init DONE, the initialization procedure is complete.

Do *not* press PRESET or recall another instrument state. You must use the instrument state that you loaded during the initialization procedure.

Step 2. Measurement Calibration

- 1 Press *CAL*, *CAL KIT & STDS*, *SELECT CAL KIT*, *CAL KIT:7mm*, *RETURN*, *RETURN*, *CALIBRATE MENU*, *FULL 2-PORT*.
- 2 Press *ISOLATION*, *OMIT ISOLATION*, *ISOLATION DONE*.
- 3 Press *REFLECTION*.
- 4 Connect the “open” end of the open/short combination (supplied in the calibration kit) to reference test port 1, as shown in Figure 2-2.

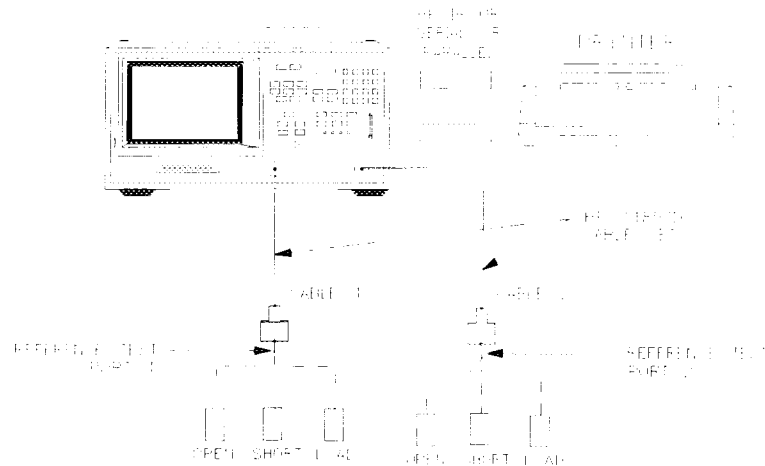

Fig. 2-2

Figure 2-2. Connections for Measurement Calibration Standards

- 5 Press *FORWARD:OPEN*.
- 6 When the HP 8702D finishes measuring the standard, connect the “short” end of the open/short combination to reference test port 1.
- 7 Press *FORWARD:SHORT*.
- 8 When the HP 8702D finishes measuring the standard, connect the 50 ohm termination (supplied in the calibration kit) to reference test port 1.
- 9 Press *FORWARD:LOAD*.
- 10 When the HP 8702D finishes measuring the standard, connect the “open” end of the open/short combination to reference test port 2.

Step 2. Measurement Calibration

- 11 Press *REVERSE:OPEN*.
- 12 When the HP 8702D finishes measuring the standard, connect the “short” end of the open/short combination to reference test port 2.
- 13 Press *REVERSE:SHORT*.
- 14 When the HP 8702D finishes measuring the standard, connect the 50 ohm termination to reference test port 2.
- 15 Press *REVERSE:LOAD*.
- 16 When the HP 8702D finishes measuring the standard, press *STANDARDS DONE*. The HP 8702D briefly displays, *COMPUTING CAL COEFFICIENTS*.
- 17 Connect the test port cables as shown Figure 2-3.

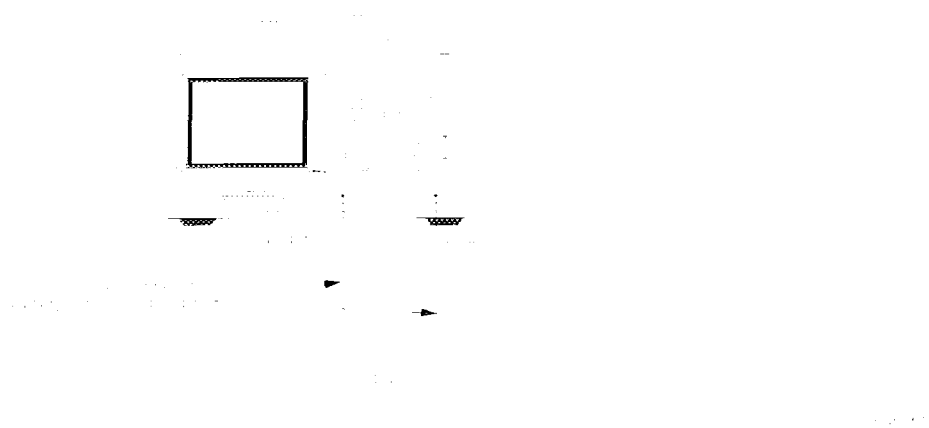

Figure 2-3. Transmission Calibration Setup

- 18 Press *TRANSMISSION, FWD TRANS THRU*.
- 19 When the HP 8702D finishes the measurement, press *FWD MATCH THRU*.
- 20 When the HP 8702D finishes the measurement, press *REV TRANS THRU*.
- 21 When the HP 8702D finishes the measurement, press *REV MATCH THRU*.
- 22 When the HP 8702D displays, *PRESS 'DONE' IF FINISHED WITH STD (s)*, press *STANDARDS DONE, DONE 2-PORT CAL*.
- 23 Press *SAVE/RECALL, SELECT DISK, INTERNAL MEMORY, RETURN, SAVE STATE* to save the calibration into the HP 8702D internal memory.
- 24 When the HP 8702D finishes saving the instrument state, press *SELECT DISK, INTERNAL DISK*.

Step 3. Device Verification

- 1 Press **SYSTEM**, **SERVICE MENU**, **TESTS**, **28**, **x1**, **EXECUTE TEST**.
- 2 At the prompt, connect the 20 dB attenuator (supplied in the verification kit) as shown in Figure 2-4.
- 3 Press **CONTINUE** to run the test:
 - If you switched the record function *off*, you have to press **CONTINUE** after each S-parameter measurement.
 - If you switched the record function *on*, the HP 8702D measures all S-parameters (magnitude and phase) without pausing. Also, the HP 8702D only displays and prints the pass/fail information for the S-parameter measurements that are valid for system verification.

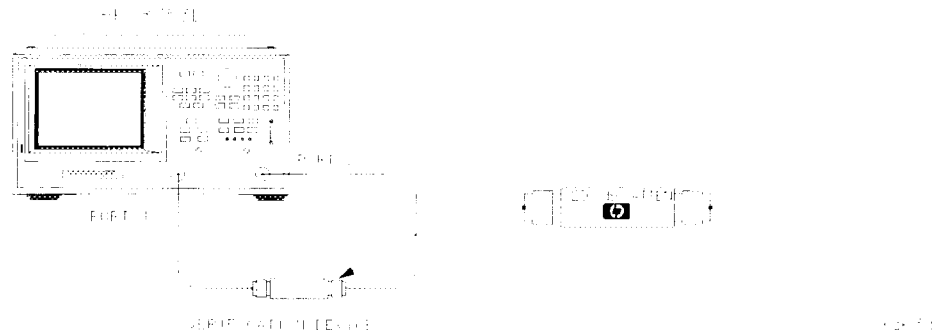

Figure 2-4. Connections for the 20 dB Verification Device

- 4 When the HP 8702D finishes all the measurements, connect the 50 dB attenuator (supplied in the verification kit), as shown in Figure 2-5.

Step 3. Device Verification

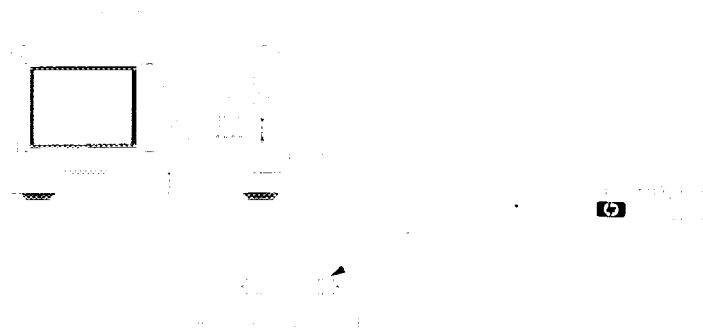

Figure 2-5. Connections for the 50 dB Verification Device

- 5 Press \uparrow , 29, x1, *EXECUTE TEST, CONTINUE*.
- 6 When all measurements are complete, replace the verification device with the verification mismatch, as shown in Figure 2-6. Be sure that you connect Port A of the verification mismatch to reference test port 1.

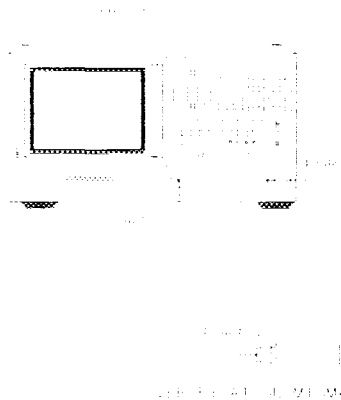

Figure 2-6. Mismatch Device Verification Setup

- 7 Press *RETURN, TESTS, 30, x1, EXECUTE TEST, CONTINUE*.
- 8 When the HP 8702D finishes all the measurements, connect the mismatch verification device, as shown in Figure 2-7. Notice that Port B is now connected to reference test port 1.

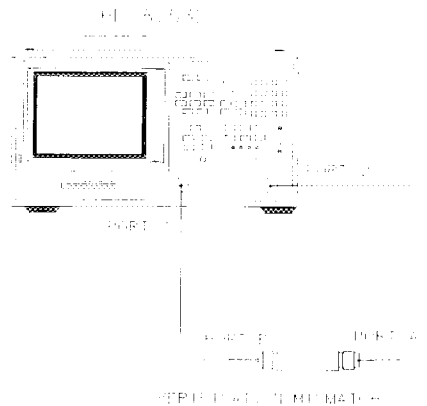

Figure 2-7. Mismatch Device Verification Setup

- 9 Press *RETURN*, *TESTS*, 31, x1, *EXECUTE TEST*, *CONTINUE*.
- 10 You have completed the system verification procedure when the HP 8702D displays, *Ver Def 4 DONE*.

In Case of Difficulty

- 1** Inspect all connections. Do *not* disconnect the cables from the HP 8702D test ports. Doing so will invalidate the calibration that you have done earlier.
- 2** Press PRESET, SAVE/RECALL, *SELECT DISK*, INTERNAL MEMORY, RETURN.
- 3** Using the front panel knob, highlight the title of the full 2-port calibration that you have done earlier, then press *RECALL STATE*.
- 4** Repeat “Step 3. Device Verification” on page 2-7.
- 5** If the HP 8702D still fails the test, check the measurement calibration as follows:
 - a** Press PRESET.
 - b** Recall the calibration by pressing SAVE/RECALL, *SELECT DISK*, INTERNAL MEMORY, RETURN.
 - c** Use the front panel knob to highlight the calibration you want to recall and press *RECALL STATE*.
 - d** Connect the short to reference test port 1.
 - e** Press MEAS, *Ref: E S11 FWD*, MENU, TRIGGER MENU, CONTINUOUS.
 - f** Press SCALE REF, *SCALE/DIV*, .05, x1.
 - g** Check that the trace response is 0.00 ± 0.05 dB.
 - h** Disconnect the short and connect it reference test port 2.
 - i** Press MEAS, *Ref: E S22 REV*.
 - j** Check that the trace response is 0.00 ± 0.05 dB.
 - k** If any of the trace responses are out of the specified limits, repeat the “Measurement Calibration” and “Device Verification” procedures.

Manual Verification

Manual Performance Verification

The manual performance verification procedure in this chapter provides a high level of confidence that the HP 8702D is working properly. If you can locate the *HP 8702D Verification Data Disk*, perform the automated version instead, which is documented in Chapter 2, "Automated Verification".

Allow the HP 8702D to warm up for one hour before starting this procedure.

In order to run this procedure, the following equipment is required:

Calibration Kit, 7 mm	HP 85031B
Verification Kit, 7 mm	HP 85029B
Test Port Extension Cable Set, 7 mm	HP 11857D
Printer	HP ThinkJet/DeskJet/LaserJet

HP 8753D is shown in the figures

The procedures in this chapter are designed to work with HP 8702D and HP 8753D instruments. Because of this, many of the figures label the instrument being tested as an HP 8753D. Simply substitute your HP 8702D for the HP 8753D.

What you'll find in this chapter

- Step 1. Initialization 3-3
- Step 2. Measurement Calibration 3-5
- Step 3. Device Verification 3-7
- In Case of Difficulty 3-11

Step 1. Initialization

- 1 Connect the equipment as shown in Figure 3-1. Let the HP 8702D warm up for one hour.

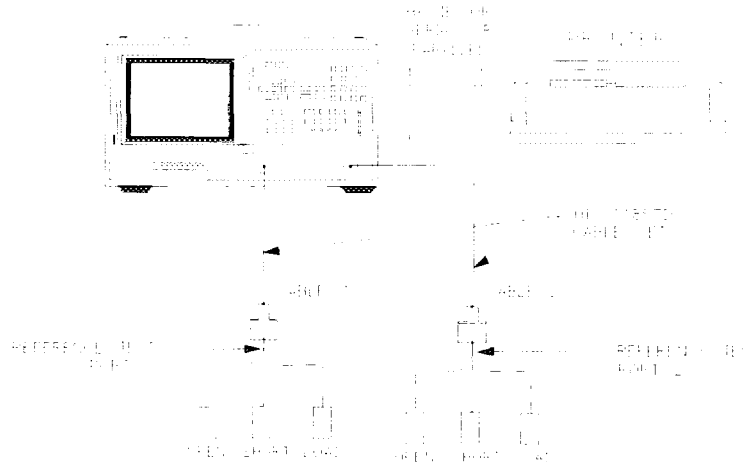

Figure 3-1. System Verification Test Setup

- 2 While the equipment is warming up, review the connector care information in the *HP 8702D User's Guide*.
- 3 Set up the system to print the verification data:
 - a Press LOCAL, SYSTEM CONTROLLER.
 - b Press SET ADDRESSES, PRINTER PORT.
 - c Press the softkey that corresponds to your printer port.
 - d If you have difficulty with the printer:
 - If the interface on your printer is HP-IB, verify that the printer address is set to 1.
 - If the interface on your printer is serial or parallel, be sure that you correctly selected the printer port *and* printer type (refer to the *HP 8702D User's Guide* for more information on how to do these tasks).

Manual Verification

Step 1. Initialization

- 4 Insert the verification kit disk into the HP 8702D disk drive.
- 5 Press PRESET, SAVE/RECALL, *SELECT DISK*, *INTERNAL DISK*.
- 6 Press SYSTEM, *SERVICE MENU*, *TESTS*, *SYS VER TESTS*, *EXECUTE TEST*.
- 7 When the HP 8702D displays, Sys Ver Init DONE, the test is complete.

CAUTION

Do *not* press PRESET or recall another instrument state. You must use the instrument state that you loaded during the initialization procedure.

Step 2. Measurement Calibration

- 1** Press *MENU*, *POWER*, *-2*, *x1* to set the HP 8702D test port power to -2 dBm.
- 2** Press *CAL*, *CAL KITS & STDS*, *SELECT CAL KIT*, *CAL KIT:7mm*, *RETURN*, *RETURN*, *CALIBRATE MENU*, *FULL 2-PORT*.
- 3** Press *ISOLATION*, *OMIT ISOLATION*, *ISOLATION DONE*.
- 4** Press *REFLECTION*.
- 5** Connect the “open” end of the open/short combination (supplied in the calibration kit) to reference test port 1, as shown in Figure 3-1.
- 6** Press *FORWARD:OPEN*.
- 7** When the HP 8702D finishes measuring the standard, connect the “short” end of the open/short combination to reference test port 1.
- 8** Press *FORWARD:SHORT*.
- 9** When the HP 8702D finishes measuring the standard, connect the 50 ohm termination (supplied in the calibration kit) to reference test port 1.
- 10** Press *REFLECTION*, *FORWARD:LOAD*.
- 11** When the HP 8702D finishes measuring the standard, connect the “open” end of the open/short combination to reference test port 2, as shown in Figure 3-1.
- 12** Press *REVERSE:OPEN*.
- 13** When the HP 8702D finishes measuring the standard, connect the “short” end of the open/short calibration standard to reference test port 2.
- 14** Press *REVERSE:SHORT*.
- 15** When the HP 8702D finishes measuring the standard, connect the 50 ohm termination to reference test port 2.
- 16** Press *REVERSE:LOAD*.
- 17** When the HP 8702D finishes measuring the standard, press *STANDARDS DONE*.
- 18** Connect the test port cables together as shown in Figure 3-2.

Step 2. Measurement Calibration

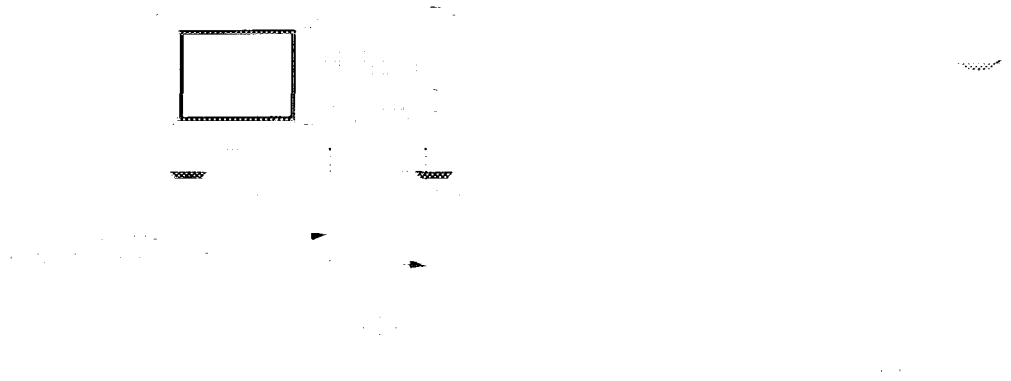

Figure 3-2. Transmission Calibration Setup

- 19** Press *TRANSMISSION, FWD TRANS THRU*.
- 20** When the HP 8702D finishes measuring the standard, press *FWD MATCH THRU*.
- 21** When the HP 8702D finishes measuring the standard, press *REV TRANS THRU*.
- 22** When the HP 8702D finishes measuring the standard, press *REV MATCH THRU*.
- 23** When the HP 8702D finishes measuring the standard, press *STANDARDS DONE, DONE 2-PORT CAL*.
- 24** Press *SAVE/RECALL, SELECT DISK, INTERNAL MEMORY, RETURN, SAVE STATE* to save the measurement calibration into the HP 8702D internal memory.
- 25** Press *SELECT DISK, INTERNAL DISK*.

Step 3. Device Verification

- 1 Press SYSTEM, SERVICE MENU, TESTS, 28, x1, EXECUTE TEST.
- 2 Connect the 20 dB attenuator (supplied in the verification kit) as shown in Figure 3-3.



Figure 3-3. Connections for the 20 dB Verification Device

- 3 Press CONTINUE to run the test.
- 4 Press MENU, POWER, -2, x1, CAL, CORRECTION ON.
- 5 Press COPY, PRINT MONOCHROME to obtain the graphical representation of the measurement.
- 6 Press COPY, LIST, PRINT ALL MONOCHROME if you prefer a tabular representation of the measurement.
- 7 Press SYSTEM, SERVICE MENU, TEST OPTIONS, CONTINUE TEST.
Ignore the error message, CAUTION: CALIBRATION REQUIRED.
- 8 Press MENU, POWER, -2, x1, CAL, CORRECTION ON.

Step 3. Device Verification

For those S-parameter measurements with upper and lower point limits shown on the HP 8702D display, you will notice that when you press the *CORRECTION ON* softkey, the measurement test status changes from FAIL to PASS.

If the test status remains FAIL after you press *CORRECTION ON*, refer to "In Case of Difficulty" on page 3-11.

- 9** Repeat Step 5 through Step 8 until you have made all the S-parameter measurements for the verification device.

For each verification device, there are a total of eight measurements (magnitude and phase for the four S-parameters).

- 10** When the HP 8702D displays, Ver Dev 1 FAIL, proceed to the next step only if *all* the tested S-parameter measurements show a PASS status after you activate error correction in Step 8. Otherwise, refer to "In Case of Difficulty" on page 3-11.
- 11** Connect the 50 dB attenuator (supplied in the verification kit) as shown in Figure 3-4.



Figure 3-4. Connections for the 50 dB Verification Device

- 12** Press *TESTS*, 29, x1, *EXECUTE TEST*, *CONTINUE*.
Ignore the error message.
- 13** Press *MENU*, *POWER*, -2, x1, *CAL*, *CORRECTION ON*.
- 14** Repeat Step 5 through Step 8 until you have made all the S-parameter measurements for the verification device.

- 15 When the HP 8702D displays, *Ver Dev 2 FAIL*, proceed to the next step only if *all* S-parameter measurements show a *PASS* status under the same condition mentioned in Step 10.
- 16 Connect the verification mismatch (supplied in the kit) as shown in Figure 3-5. Be sure port A of the verification mismatch is connected to reference test port 1.

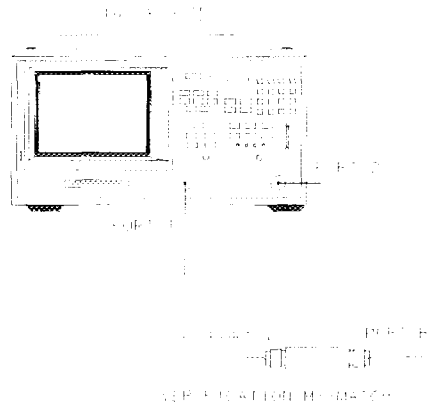

Figure 3-5. Mismatch Device Verification Setup

- 17 Press *TESTS*, 30, x1, *EXECUTE TEST*, *CONTINUE*.
Ignore the error message.
- 18 Press *MENU*, *POWER*, -2, x1, *CAL*, *CORRECTION ON*.
- 19 Repeat Step 5 through Step 8 until you have made all the S-parameter measurements for the verification device.
- 20 When the HP 8702D displays, *Ver Dev 3 FAIL*, proceed to the next step only if *all* S-parameter measurements show a *PASS* status under the same condition mentioned in Step 10.
- 21 Connect the verification mismatch as shown in Figure 3-6. Notice that port B of the verification mismatch is now connected to the reference test port 1.

Step 3. Device Verification

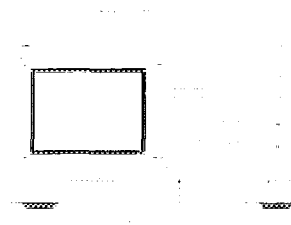

Figure 3-6. Mismatch Device Verification Setup

- 22** Press *TESTS*, 31, x1, *EXECUTE TEST*, *CONTINUE*.
Ignore the displayed error message.
- 23** Press *MENU*, *POWER*, -2, x1, *CAL*, *CORRECTION ON*.
- 24** Repeat Step 5 through Step 8 until you have made all the S-parameter measurements for the verification device.
- 25** The test is complete when the HP 8702D displays, *Ver Def 4 FAIL*, and *all* S-parameter measurements show a *PASS* status under the same condition mentioned in Step 10.

In Case of Difficulty

- 1** Inspect all connections. Do *not* disconnect the cables from the HP 8702D test ports. Doing so will invalidate the calibration done earlier.
- 2** Press PRESET, SAVE/RECALL, *SELECT DISK*, *INTERNAL MEMORY*, *RETURN*. Using the front panel knob, highlight the full 2-port cal done earlier and press *RECALL STATE*.
- 3** Repeat "Step 3. Device Verification" on page 3-7.
- 4** If the test still fails, do the following to check the calibration:
 - a** Press PRESET, *SAVE/RECALL*, *SELECT DISK*, *INTERNAL MEMORY*, *RETURN*.
 - b** Use the front panel knob to highlight the calibration you want to recall and press *RECALL STATE*.
 - c** Press MENU, *TRIGGER MENU*, *CONTINUOUS* to trigger the continuous sweeps.
 - d** Connect the short to reference test port 1.
 - e** Press MEAS, *Ref: E S11 FWD*, MENU, *TRIGGER MENU*, *CONTINUOUS*.
 - f** Press SCALE REF, *SCALE/DIV*, .05, x1.
 - g** Check to be sure the trace response is 0.00 ± 0.05 dB.
 - h** Disconnect the short and connect it the reference test port 2.
 - i** Press MEAS, *Ref: E S22 REV*.
 - j** Check to be sure the trace response is 0.00 ± 0.05 dB.
 - k** If any of the trace responses are out of the specified limits, repeat the procedures in this chapter.

Manual Verification
In Case of Difficulty



Performance Tests

Manual Performance Tests

This chapter contains procedures which test the electrical performance of the HP 8702D. If you are using an HP 8702D Option 011, perform the tests in Chapter 6, "Performance Tests – Option 011". Before starting these procedures, allow the instrument to warm up for one hour.

Each procedure has a "Performance Test Record" that is located at the end of this chapter.

To obtain the same quality of performance testing that Hewlett-Packard has administered at the factory, you must perform:

- the system verification procedures in Chapter 2, "Automated Verification" or Chapter 3, "Manual Verification".
- *all* of the performance test procedures in this chapter.

This quality of performance testing guarantees that the analyzer is performing within *all* of the published specifications. Hewlett-Packard will issue a Certificate of Calibration for your analyzer if two conditions are met.

- 1 Your analyzer passes all the performed tests.
- 2 The equipment and standards that you used to perform the tests are traceable to a national standards institute.

NOTE

If you have a particular type of measurement application that does not use all of the analyzer's measurement capabilities, you may ask your nearest Hewlett-Packard Sales and Service Office for a subset of specifications that you want verified. However, this does create a potential for making incorrect measurements, by using a different application than what was specified.

WARNING

Any servicing, adjustment, maintenance, or repair of this product must be performed only by qualified personnel. Repair information provided in the *In Case of Difficulty* sections of this chapter are provided for qualified service personnel and are intended to be used with the HP 8753D Service Guide.

HP 8753D is shown in the figures

The procedures in this chapter are designed to work with HP 8702D and HP 8753D instruments. Because of this, many of the figures label the instrument being tested as an HP 8753D. Simply substitute your HP 8702D for the HP 8753D.

What you'll find in this chapter

1. Test Port Output Frequency Range and Accuracy 4-4
 2. External Source Mode Frequency Range 4-6
 3. Test Port Output Power Accuracy 4-8
 4. Test Port Output Power Range and Linearity 4-11
 5. Minimum R Channel Level 4-14
 6. Test Port Input Noise Floor Level 4-19
 7. Test Port Input Frequency Response 4-23
 8. Test Port Crosstalk 4-34
 9. Calibration Coefficients 4-39
 10. System Trace Noise (Only for Analyzers without Option 006) 4-46
 11. System Trace Noise (Only for Analyzers with Option 006) 4-48
 12. Test Port Input Impedance 4-51
 13. Test Port Receiver Magnitude Dynamic Accuracy 4-55
 14. Test Port Receiver Phase Dynamic Accuracy 4-63
 15. Test Port Receiver Magnitude Compression 4-65
 16. Test Port Receiver Phase Compression 4-68
 17. Test Port Output/Input Harmonics (Option 002 Analyzers without Option 006 Only) 4-71
 18. Test Port Output/Input Harmonics (Option 002 Analyzers with Option 006 Only) 4-76
- Performance Test Records 4-81

1. Test Port Output Frequency Range and Accuracy

1. Test Port Output Frequency Range and Accuracy

Perform this test to verify the frequency accuracy of the HP 8702D over its entire operating frequency range.

Required Equipment

Frequency Counter	HP 5343A
Cable, 50 Ω , Type-N, 24-inch	HP P/N 8120-4781
Adapter, APC-3.5 (f) to Type-N (f)	HP P/N 1250-1745
Adapter, APC-7 to Type-N (f)	HP P/N 11524A
Adapter, Type-N (f) to BNC (m)	HP P/N 1250-1477

Additional Equipment for HP 8702D Option 075:

Minimum Loss Pad, 50 Ω to 75 Ω	HP 11852B
----------------------------------------------------	-----------

Procedure

- 1 Connect the equipment as shown in Figure 4-1.

1. Test Port Output Frequency Range and Accuracy

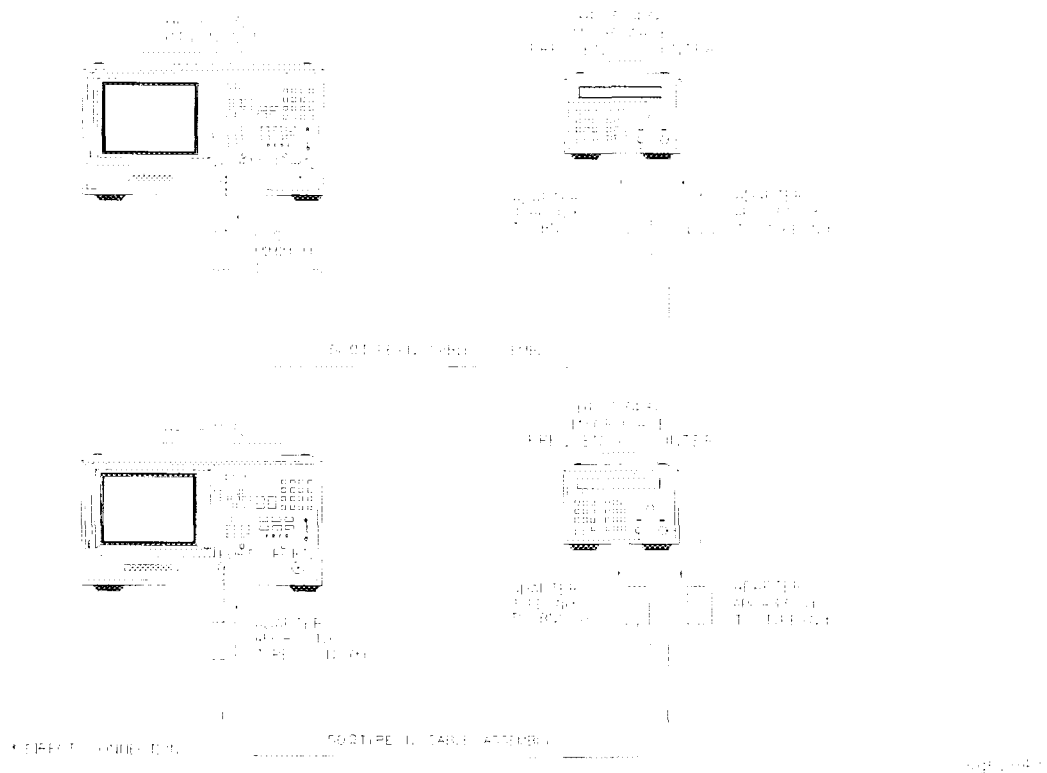

Figure 4-1. Test Port Output Frequency Range and Accuracy Test Setup

- 2 Press PRESET, MENU, *CW FREQ.*
- 3 Press 30, k/m and write the frequency counter reading on the “Performance Test Record.”
- 4 Repeat Step 3 for each instrument frequency listed in the “Performance Test Record.”

In Case of Difficulty

- 1 If any measured frequency is close to the specification limits, check the time base accuracy of the counter used.
- 2 If the analyzer fails by a significant margin at *all* frequencies (especially if the deviation increases with frequency), the master time base probably needs adjustment. In this case, refer to the *HP 8753D Service Guide*. The “Fractional-N Frequency Range Adjustment” also affects frequency accuracy.

2. External Source Mode Frequency Range

2. External Source Mode Frequency Range

Perform this test to verify that the analyzer's reference channel, input R, is capable of phase locking to an external CW signal.

Required Equipment

External Source	HP 83640A
Cable, APC-7, 24-inch	HP P/N 8120-4779
Adapter, APC-3.5 (f) to APC-7	HP P/N 1250-1747
Adapter, APC-3.5 (m) to APC-7	HP P/N 1250-1746

Procedure

- 1 On the external source, press PRESET, CW, 10, MHz/msec, POWER LEVEL, $-/\leftarrow$, 20, GHz/dB(m).
- 2 Connect the equipment as shown in Figure 4-2.

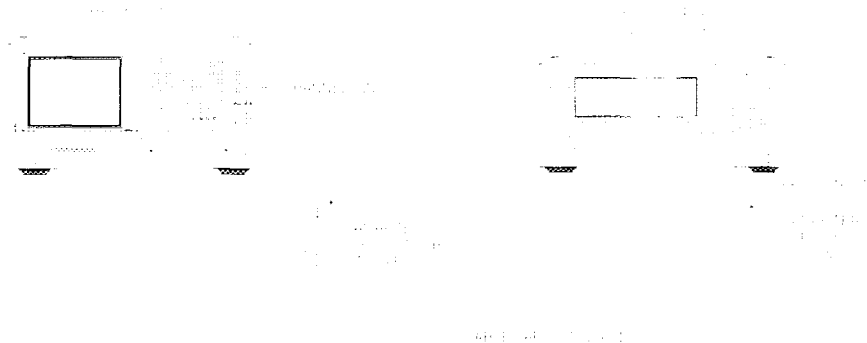

Figure 4-2. External Source Mode Frequency Range Test Setup

- 3 On the analyzer, press PRESET, MEAS, *INPUT PORTS, R*.
- 4 Press SYSTEM, *INSTRUMENT MODE, EXT SOURCE AUTO*, MENU, *CW FREQ, 10, M/μ*.

2. External Source Mode Frequency Range

- 5** Check to see if the analyzer is phase locking to the external CW signal:
 - If the analyzer displays any phase lock error messages, write “unlock” in the “Performance Test Record” for the set CW signal.
 - If the analyzer does *not* display any phase lock error messages, write “lock” in the “Performance Test Record” for the set CW signal.
- 6** On the external source, press CW, 50, MHz/ μ .
- 7** On the analyzer, press 50, M/ μ .
- 8** Repeat Step 5 through Step 7 for the other external source CW frequencies listed in the “Performance Test Record.” For analyzers with Option 006, change the power sensor to the HP 8481A for frequencies above 4 GHz.

**In Case of
Difficulty**

- 1** Be sure the external source power is set within 0 to -25 dBm.
- 2** Make sure the analyzer’s “Ext Source Auto” feature is selected. In addition, verify that the analyzer is set to measure its input channel R.
- 3** Verify that all connections are tight.

3. Test Port Output Power Accuracy

3. Test Port Output Power Accuracy

Perform this test to confirm the accuracy of the HP 8702D source output power.

Required Equipment

Equipment Required for 50Ω Analyzers

Power Meter HP 436A/437B/438A
Power Sensor HP 8482A
Adapter, APC-7 to Type-N (f) HP 11524A

Additional Equipment Required for Analyzers with Option 006

Power Sensor HP 8481A

Equipment Required for 75Ω Analyzers

Power Meter HP 436A/437B/438A
Power Sensor HP 8483A Option H03

Procedure

- 1 Zero and calibrate the power meter. For more information of how to perform this task, refer to the power meter operating manual.
- 2 Connect the equipment as shown in Figure 4-3.

3. Test Port Output Power Accuracy

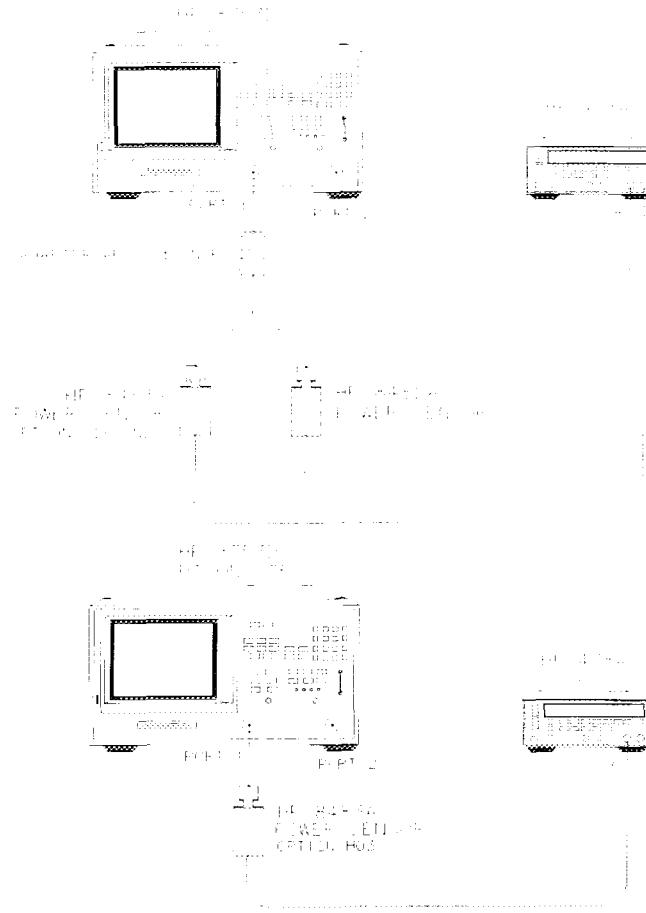

Figure 4-3. Source Output Power Accuracy Test Setup

- 3 Press PRESET.

NOTE

The factory preset test port power is 0 dBm.

- 4 Press MENU, *CWFREQ*, 300, k/m. Set the calibration factor on the power meter for this CW frequency.

3. Test Port Output Power Accuracy

- 5 Write the power meter reading on the "Performance Test Record."
- 6 Repeat Step 4 and Step 5 for each CW frequency listed in the "Performance Test Record."

**In Case of
Difficulty**

- 1 Be sure the source power is switched on. Press *MENU*, *POWER*. Check the *SOURCE PWR* softkey, *ON* should be highlighted. Otherwise, press *SOURCE PWR* to switch on the source power.
- 2 Refer to the *HP 8753D Service Guide* for more troubleshooting information.

4. Test Port Output Power Range and Linearity

4. Test Port Output Power Range and Linearity

Perform this test to verify the analyzer's test port output power range and power level linearity at selected CW frequencies.

Required Equipment

Power Meter HP 437B/438A
 Power Sensor HP 8482A
 Adapter, APC-7 to Type-N (f) HP 11524A

Additional Required Equipment for Analyzers with Option 006

Power Sensor HP 8481A

Additional Required Equipment for Analyzers with Option 075

Power Sensor HP 8483A Option H03

Procedure

- 1** Zero and calibrate the power meter. Refer to the power meter operating and service manual for more information on how to do this task.
- 2** On the analyzer, press PRESET, MENU, *CW FREQ*, 300, k/m. Set the power meter calibration factor for this CW frequency.
- 3** Connect the equipment as shown in Figure 4-4.

4. Test Port Output Power Range and Linearity

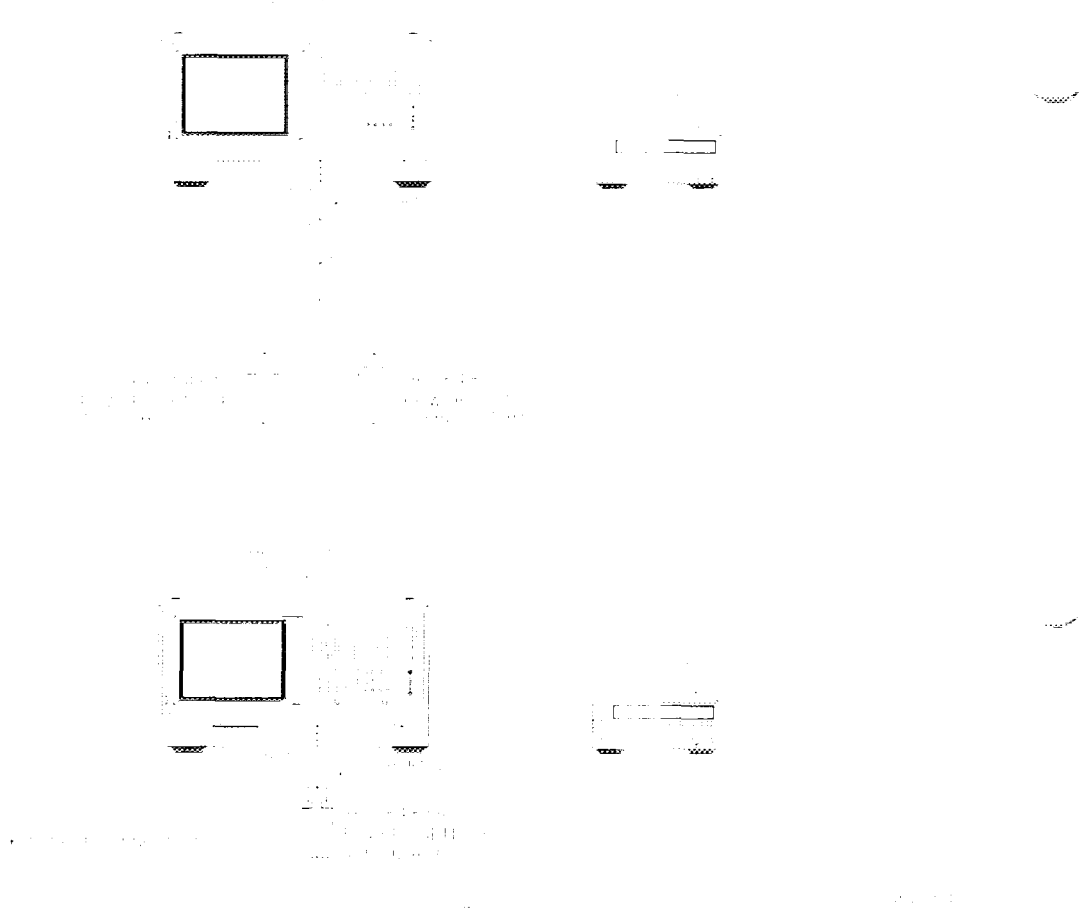

Figure 4-4. Test Port Output Power Range and Accuracy Test Setup

- 4 On the HP 438A, press REL. This sets the current power level for relative power measurement.
- 5 On the analyzer, press MENU, *POWER*, *PWR RANGE MAN*.
- 6 Write the power meter reading in the "Results Measured" column on the "Performance Test Record."
- 7 Calculate the difference between the analyzer test port power (which appears on the analyzer's display) and the power meter reading. Write the result in the "Power Level Linearity" column on the "Performance Test Record."

4. Test Port Output Power Range and Linearity

- 8** Repeat Step 5 through Step 7 for the other power levels listed in the "Performance Test Record."
- 9** Press *CW FREQ*, 3, G/n.
- 10** Set the power meter calibration factor for this CW frequency and press REL to set the reference at this new frequency.
- 11** Press MENU, *POWER*, -15, x1.
- 12** Write the power meter reading in the "Results Measured" column on the "Performance Test Record."
- 13** Calculate the difference between the analyzer test port power and the power meter reading. Write the result in the "Power Level Linearity" column of the "Performance Test Record."
- 14** Repeat Step 11 through Step 13 for the other power levels listed in the "Performance Test Record."

In Case of Difficulty

- 1** Ensure that the power meter and power sensor(s) are operating to specifications. Be sure you set the power meter calibration factor for the CW frequency that you are testing.
- 2** Verify that there is power coming out of the analyzer's test port 1. Be sure you did *not* accidentally switch off the analyzer's internal source. If you did so, press MENU, *POWER*, *SOURCE PWR ON*.
- 3** Repeat this performance test.

5. Minimum R Channel Level

5. Minimum R Channel Level

Perform this test to determine the minimum R channel input power level at which phase lock can be accomplished.

Required Equipment**For 50 Ω Analyzers**

Adapter, APC-3.5 (m) to APC-7 HP P/N 1250-1746
 Cable, APC-7 24-inch HP P/N 8120-4779

For 75 Ω Analyzers (Option 075)

Minimum Loss Pad, 50 Ω to 75 Ω HP 11852B
 Cable, 50 Ω Type-N, 24-inch HP P/N 8120-4781
 Adapter, APC-3.5 (m) to Type-N (f) HP P/N 1250-1750

Procedure

- 1 Connect the equipment as shown in Figure 4-5.



Figure 4-5. Minimum R Channel Level Test Setup

- 2 Press PRESET, MEAS, *INPUT PORTS*, *R*.
- 3 Press MENU, *POWER*, *PWR RANGE MAN*, *POWER RANGES*, *RANGE 4 -55 to -30*.
- 4 Press SCALE REF, *REFERENCE VALUE*, *-70*, *x1*.

5. Minimum R Channel Level

- 5 Press MENU, *CW FREQ*, 300, k/m.
- 6 Press MENU, *POWER*, -65, x1.
The analyzer displays the message, CAUTION: NO IF FOUND: CHECK R INPUT LEVEL.
- 7 Press \uparrow to increase the test port power by 1 dBm.
- 8 If the analyzer displays a phase lock error message, continue increasing the test port power until phase lock is achieved.
- 9 Write the test port power, that is displayed on the analyzer, on the "Performance Test Record."
- 10 Repeat Step 5 through Step 9 for the other CW frequencies listed in the "Performance Test Record."

In Case of Difficulty**WARNING**

These servicing instructions are for use by qualified personnel only. To avoid electrical shock, do not perform any servicing unless you are qualified to do so.

WARNING

The opening of covers or removal of parts is likely to expose dangerous voltages. Disconnect the instrument from all voltage sources while it is being opened.

WARNING

The power cord is connected to internal capacitors that may remain live for five seconds after disconnecting the plug from its power supply.

- 1 Check the flexible RF cable (W8, as shown in Figure 4-6) between the R sampler assembly (A4) and the A11 phase lock assembly. Make sure it is connected between A11J1 (PL IF IN) and 1st IF Out.

CAUTION

Loop the W8 cable around the A5 sampler as shown in Figure 4-6. *Do not* push the cable down next to the A11 phase lock assembly.

5. Minimum R Channel Level

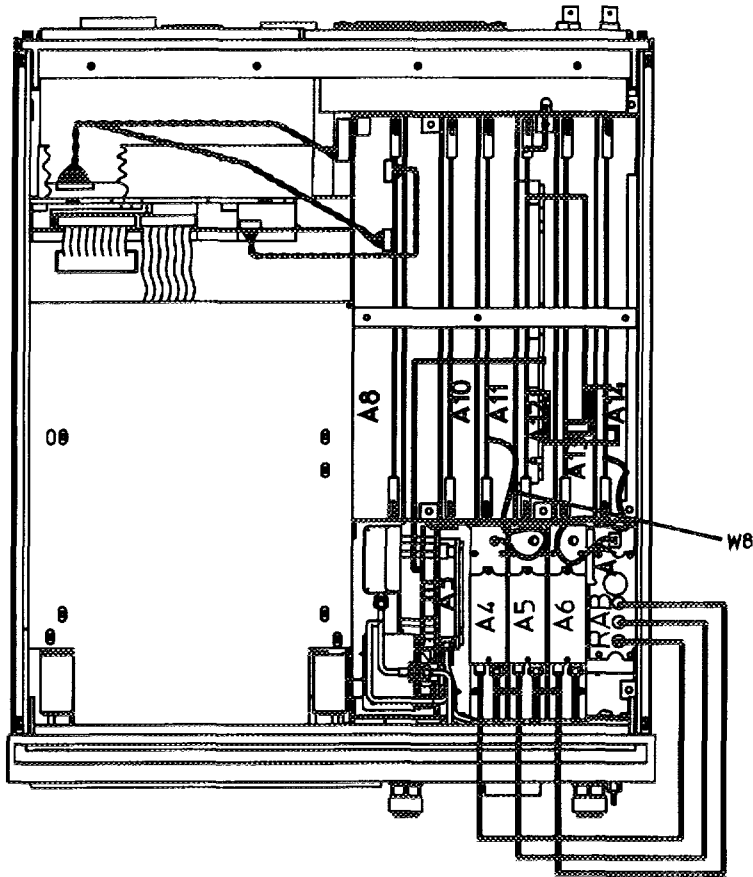

sg6209d

Figure 4-6. Flexible RF Cable Location

- 2 Using an ohmmeter, verify that the RF cable is *not* open. In addition, examine both the cable connectors - measure the resistance between the cable center pin and the cable connector and make sure it is *not* close to zero.

- 3 Check the R sampler by substituting it with the B sampler (A6).
 - a Move cable W8 to the B sampler (A6), as shown in Figure 4-7.

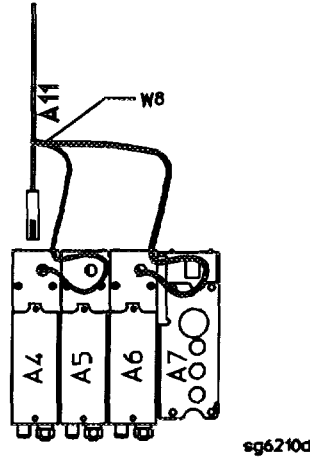

Figure 4-7. Connections for Substituting the R Sampler (A4)

- 4 Connect the equipment as shown in Figure 4-8.

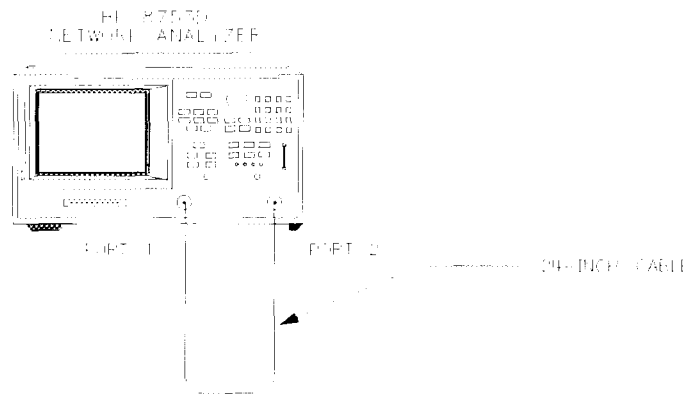

Figure 4-8. Setup for Checking the R Sampler (A4)

5. Minimum R Channel Level

- 5 Repeat the test, but select the B sampler (A6) by pressing MEAS, *INPUT PORTS*, B in Step 2. Use the following specifications:
 - 300 kHz to 3 GHz < -27 dBm
 - 3 GHz to 6 GHz < -22 dBm
- 6 If the analyzer fails the test, replace the A11 assembly.
- 7 Verify that the high/low band adjustments are still within specifications. For more information on how to perform this task, refer to the *HP 8753D Service Guide*.
- 8 Refer to the *HP 8753D Service Guide* for more troubleshooting information.

6. Test Port Input Noise Floor Level

Perform this test to determine the HP 8702D port 1 and port 2 noise floor levels at the input test ports.

Required Equipment

For 50 Ω Analyzers

Calibration Kit, 7 mm HP 85031B

For 75 Ω Analyzers

Calibration Kit, Type-N HP 85036B

Procedure

Port 1 Noise Floor Level from 50 kHz to 3 GHz (IF BW= 3 kHz)

- 1 Connect the equipment as shown in Figure 4-9.

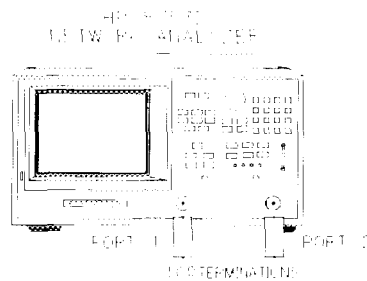

Figure 4-9

Figure 4-9. Source Input Noise Floor Test Setup

- 2 Press PRESET, MENU, *POWER*, -85, x1, STOP, 3, G/n.
- 3 Press MEAS, *INPUT PORTS*, A, *TESTPORT 2*, FORMAT, *LIN MAG*, SCALE REF, *AUTO SCALE*.
- 4 Press MARKER FCTN, *MARKER MODE MENU*, *STATS ON*, MENU, *TRIGGER MENU*, *SINGLE*.
- 5 When the analyzer finishes the sweep, notice the mean value (which appears on the analyzer display).

6. Test Port Input Noise Floor Level

- 6** Convert the measured linear magnitude mean value to log magnitude, using this equation.

$$\text{Power (dBm)} = 20 * [\log_{10}(\text{linear magnitude mean value})]$$

NOTE

Notice that the mean value that is displayed on the analyzer is in μ Units. So, for example, if the displayed value is 62 μ U, the value that you would put in the equation is (62×10^{-6}) .

- 7** Write this calculated value on the "Performance Test Record."

***Port 1 Noise Floor Level from 50 kHz to 3 GHz
(IF BW= 10 Hz)***

- 8** Press AVG, *IF BW*, 10, x1 to change the IF bandwidth to 10 Hz.
- 9** Press MENU, *TRIGGER MENU*, *SINGLE*.
- 10** When the analyzer finishes the sweep, notice the mean value.
- 11** Convert the measured linear magnitude mean value to log magnitude, using this equation.

$$\text{Power (dBm)} = 20 * [\log_{10}(\text{linear magnitude mean value})]$$

- 12** Write this calculated value on the "Performance Test Record."

***Port 2 Noise Floor Level from 50 kHz to 3 GHz
(IF BW= 10 Hz)***

- 13** Press MEAS, *INPUT PORTS*, *B*, *TESTPORT 1*, *FORMAT*, *LIN MAG*.
- 14** Press MENU, *TRIGGER MENU*, *SINGLE*.
- 15** When the analyzer finishes the sweep, notice the mean value.
- 16** Convert the measured linear magnitude mean value to log magnitude, using this equation.

$$\text{Power (dBm)} = 20 * [\log_{10}(\text{linear magnitude mean value})]$$

- 17** Write this calculated value on the "Performance Test Record."

***Port 2 Noise Floor Level from 50 kHz to 3 GHz
(IF BW= 3 kHz)***

- 18** Press AVG, *IF BW*, 3, k/m to change the IF bandwidth to 3 kHz.
- 19** Press MENU, *TRIGGER MENU*, *SINGLE*.
- 20** When the analyzer finishes the sweep, notice the mean value.
- 21** Convert the measured linear magnitude mean value to log magnitude, using this equation.
$$\text{Power (dBm)} = 20 * [\log_{10}(\text{linear magnitude mean value})]$$
- 22** Write this calculated value on the "Performance Test Record."
- 23** This completes the "Test Port Input Noise Floor Level" procedure if your analyzer does *not* have Option 006. Otherwise, continue with the next section.

***Port 2 Noise Floor Level from 3 GHz to 6 GHz
(IF BW= 3 kHz)***

- 24** Press START, 3, G/n, STOP, 6, G/n.
- 25** Press MENU, *TRIGGER MENU*, *SINGLE*.
- 26** When the analyzer finishes the sweep, notice the mean value.
- 27** Convert the measured linear magnitude mean value to log magnitude, using this equation.
$$\text{Power (dBm)} = 20 * [\log_{10}(\text{linear magnitude mean value})]$$
- 28** Write this calculated value on the "Performance Test Record."

***Port 2 Noise Floor Level from 3 GHz to 6 GHz
(IF BW= 10 Hz)***

- 29** Press AVG, *IF BW*, 10, x1 to change the IF bandwidth to 10 Hz.
- 30** Press MENU, *TRIGGER MENU*, *SINGLE*.
- 31** When the analyzer finishes the sweep, notice the mean value.
- 32** Convert the measured linear magnitude mean value to log magnitude, using this equation.
$$\text{Power (dBm)} = 20 * [\log_{10}(\text{linear magnitude mean value})]$$
- 33** Write this calculated value on the "Performance Test Record."

6. Test Port Input Noise Floor Level

Port 1 Noise Floor Level for 3 GHz to 6 GHz (IF BW= 10 Hz)

- 34 Press MEAS, *INPUT PORTS, A, TESTPORT 2.*
- 35 Press MENU, *TRIGGER MENU, SINGLE.*
- 36 When the analyzer finishes the sweep, notice the mean value.
- 37 Convert the measured linear magnitude mean value to log magnitude, using this equation.

$$\text{Power (dBm)} = 20 * [\log_{10}(\text{linear magnitude mean value})]$$

- 38 Write this calculated value on the "Performance Test Record."

Port 1 Noise Floor Level from 3 GHz to 6 GHz (IF BW= 3 kHz)

- 39 Press AVG, *IF BW, 3, k/m.*
- 40 Press MENU, *TRIGGER MENU, SINGLE.*
- 41 When the analyzer finishes the sweep, notice the mean value.
- 42 Convert the measured linear magnitude mean value to log magnitude, using this equation.

$$\text{Power (dBm)} = 20 * [\log_{10}(\text{linear magnitude mean value})]$$

- 43 Write this calculated value on the "Performance Test Record."

In Case of Difficulty

- 1 Perform the "ADC Linearity Correction Constants (Test 52)," located in the "Adjustments and Correction Constants" chapter of the *HP 8753D Service Guide*.
- 2 Repeat the "Test Port Input Noise Floor Level" procedure.
- 3 Suspect the A10 Digital IF assembly if the analyzer fails both test port input noise floor tests.
- 4 Refer to the *HP 8753D Service Guide* for more troubleshooting information.

7. Test Port Input Frequency Response

Perform this test to examine the vector sum of all test setup error vectors in both magnitude and phase change as a function of frequency.

Required Equipment

For 50Ω Analyzers

Power Meter HP 436A/437B/438A
 Power Sensor HP 8482A
 Cable, APC-7 24-inch HP P/N 8120-4779
 Adapter, APC-7 to Type-N (f) HP 11524A

Additional Equipment Required for Analyzers with Option 006

Power Sensor HP 8481A

For 75Ω Analyzers

Power Meter HP 436A/437B/438A
 Power Sensor HP 8483A Option H03
 Cable, Type-N HP P/N 8120-2408

Procedure

Power Meter Calibration for Test Port 1 from 300 kHz to 3 GHz

- 1 Zero and calibrate the power meter.
- 2 Connect the equipment as shown in Figure 4-10.

7. Test Port Input Frequency Response

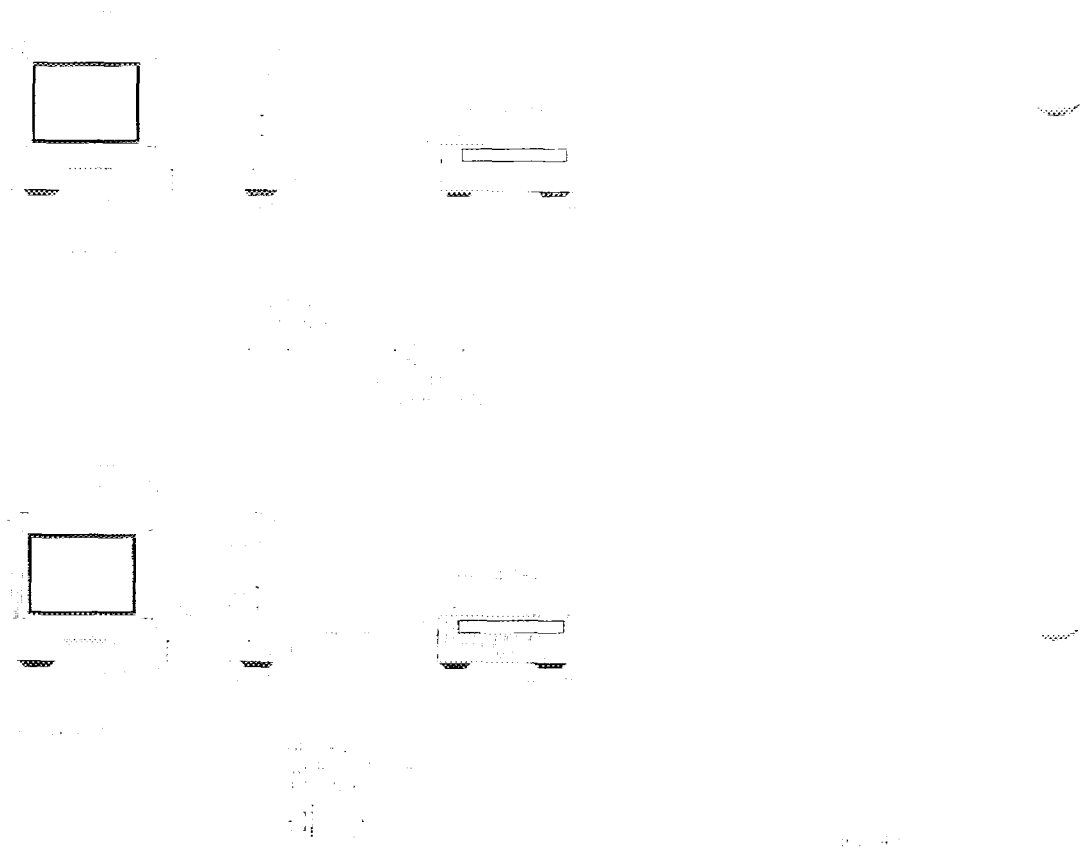

Figure 4-10. Setup for Power Meter Calibration on Test Port 1

- 3** Press PRESET, START, 300, k/m.
- 4** *Only for Analyzers with Option 006:* Press STOP, 3, G/n.
- 5** Press LOCAL, SYSTEM CONTROLLER.
- 6** Press SET ADDRESSES and POWER MTR until the analyzer shows the correct power meter model.
- 7** Press ADDRESS: PMTR/HPIB. The default power meter HP-IB address is 13. Make sure it is the same as your power meter HP-IB address. Otherwise, use the analyzer front panel keypad to enter the correct HP-IB address for your power meter.
- 8** Press MENU, NUMBER of POINTS, 51, x1.

7. Test Port Input Frequency Response

- 9 Press *POWER*, *PWR RANGE MAN* to turn the auto power range off.

NOTE

The analyzer displays the *PRm* annotation, indicating that the analyzer power range is set to *MANUAL*.

- 10 Press *PORT POWER* to uncouple the test port output power.
- 11 Press *CAL*, *PWRMTR CAL*.
- 12 Press *LOSS/SENSR LISTS*, *CAL FACTOR SENSOR A*. Refer to the back of the power sensor to locate the different calibration factor values along with their corresponding frequencies.

NOTE

The analyzer's calibration factor sensor table can hold a **MAXIMUM** of 12 calibration factor data points.

The following softkeys are included in the sensor calibration factor entries menu:

<i>SEGMENT</i>	press to select a point where you can use the front panel knob or entry keys to enter a value
<i>EDIT</i>	press to edit or change a previously entered value
<i>DELETE</i>	press to delete a point from the sensor calibration factor table
<i>ADD</i>	select this key to add a point into the sensor calibration factor table
<i>CLEAR LIST</i>	select this key to erase the entire sensor calibration factor table
<i>DONE</i>	select this key when done entering points to the sensor calibration factor table

As an example, the following are the keystrokes for entering the first two calibration factor data points for the HP 8482A power sensor (assuming *CF%* = 96.4 at 100 kHz and *CF%* = 98.4 at 300 kHz):

7. Test Port Input Frequency Response

- a From the sensor calibration factor entries menu, press *ADD*.
 - b Press *FREQUENCY*, 100, k/m. If you make an entry error, press ← and re-enter the correct value again.
 - c Press *CAL FACTOR*, 96.4, x1.
 - d Press *DONE* to terminate the first calibration factor data point entry.
 - e To enter the second cal factor data point, press *ADD*.
 - f Press *FREQUENCY*, 300, k/m.
 - g Press *CAL FACTOR*, 98.4, x1.
 - h To terminate the second calibration factor data point entry, press *DONE*.
 - i Press *SEGMENT* and use the front panel knob to scroll through the sensor calibration factors table. Check to be sure all values are entered correctly. If you spot an error, use the front panel knob to point to the data point you want to modify and press *EDIT*.
- 13** Press the appropriate softkeys to create a power sensor calibration factors table.
- 14** Press *DONE* to exit the sensor calibration factor entries menu.
- 15** Press *RETURN*, *ONE SWEEP*, *TAKE CAL SWEEP* to start the power meter calibration. Wait until the analyzer finishes the sweep, then continue with this procedure.

NOTE

The analyzer displays the *PC* annotation, indicating the power meter calibration is done and the error correction is active.

7. Test Port Input Frequency Response***Test Port 2 Input Frequency Response from 300 kHz to 3 GHz***

16 Connect the equipment as shown in Figure 4-11.



Figure 4-11. Test Port 2 Input Frequency Response Test Setup

- 17** Press MEAS, *INPUT PORTS*, *B*.
- 18** Press SCALE REF, *SCALE/DIV*, *1*, *x1*.
- 19** Press MARKER, *MARKER 1*, MARKER FCTN, *MARKER MODE MENU*, *MKR SEARCH*, *SEARCH:MIN* to put marker 1 at the minimum magnitude location of the trace.
- 20** Press MARKER, *MARKER 2*, MARKER FCTN, *MARKER MODE MENU*, *MKR SEARCH*, *SEARCH:MAX* to position marker 2 at the maximum magnitude location of the trace.
- 21** Write the marker 1 or marker 2 value (which appears on the analyzer display), whichever has the larger absolute magnitude, in the “Performance Test Record.”

7. Test Port Input Frequency Response

Power Meter Calibration on Port 2 from 300 kHz to 3 GHz

22 Connect the equipment as shown Figure 4-12.

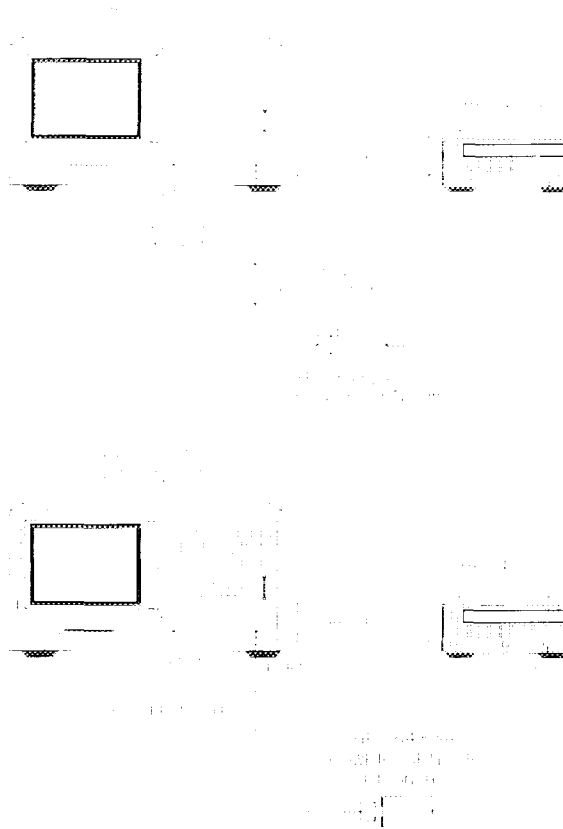

Figure 4-12. Setup for Power Meter Calibration on Test Port 2

- 23** Press MEAS, *INPUT PORTS*, *TESTPORT 2*.
- 24** Press CAL, *PWRMTR CAL*, *ONE SWEEP*, *TAKE CAL SWEEP* to start the power meter calibration for test port 2.

7. Test Port Input Frequency Response

- 25** When the analyzer displays the message, *POWER METER CALIBRATION SWEEP DONE*, connect the equipment as shown as in Figure 4-13.

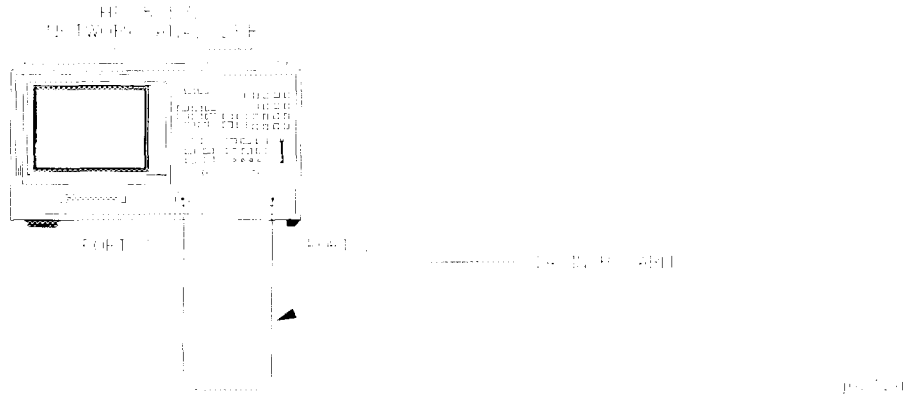

Figure 4-13. Test Port 1 Input Frequency Response Test Setup

Test Port 1 Input Frequency Response from 300 kHz to 3 GHz

- 26** Press MEAS, *INPUT PORTS, A*.
- 27** Press MARKER, *MARKER 1, MARKER FCTN, MARKER MODE MENU, MKR SEARCH, SEARCH:MIN*.
- 28** Press MARKER, *MARKER 2, MARKER FCTN, MARKER MODE MENU, MKR SEARCH, SEARCH:MAX*.
- 29** Write the marker 1 or marker 2 reading, whichever has the larger absolute magnitude, in the “Performance Test Record.”
- 30** This completes the “Test Port Input Frequency Response” procedure if your analyzer does *not* have Option 006. Otherwise, continue with the next sections.

Power Meter Calibration for Test Port 2 from 3 GHz to 6 GHz

- 31** Replace the power sensor with the HP 8481A, and then setup the power meter:
- If the power meter is an HP 438A, press LCL.
 - If the power meter is an HP 437B, press PRESET/LOCAL.
 - If the power meter is an HP 436A, cycle the line power.
- 32** Connect the equipment as shown in Figure 4-14.

7. Test Port Input Frequency Response

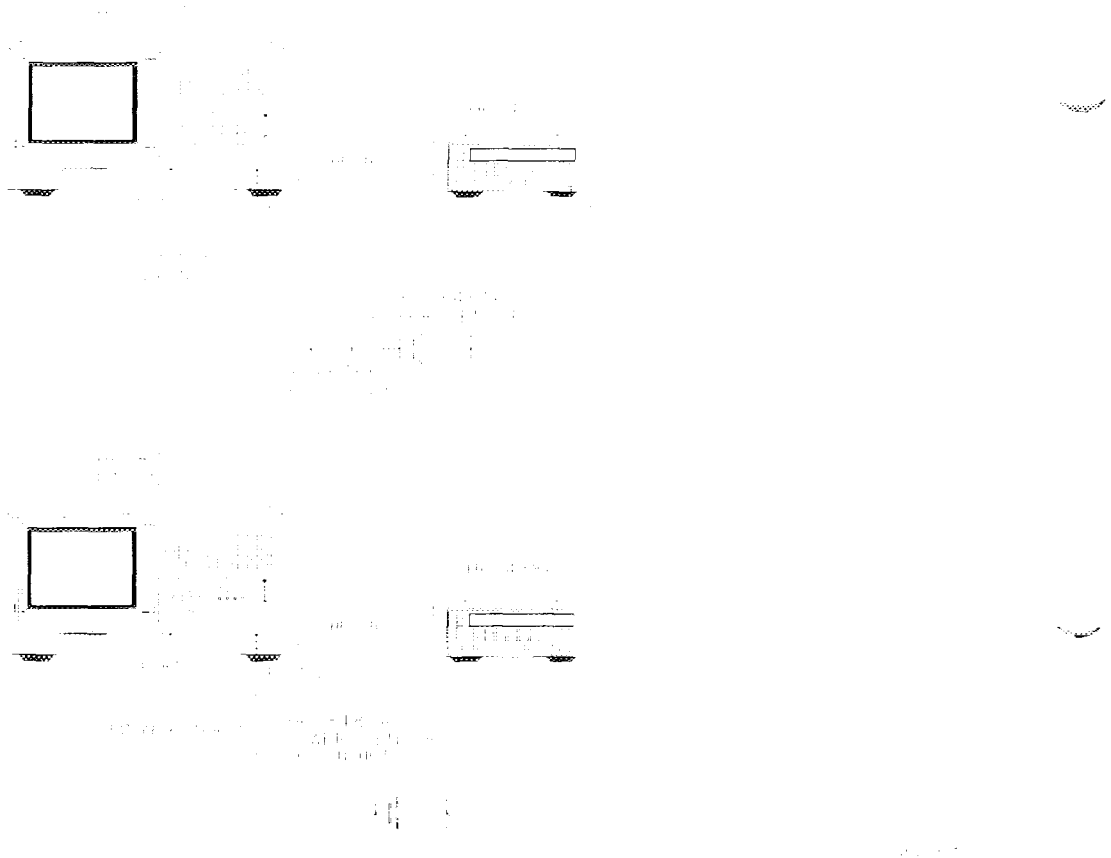

Figure 4-14. Setup for Power Meter Calibration on Test Port 2

- 33** Press *START*, 3, *G/n*, *STOP*, 6, *G/n*.
- 34** Press *CAL*, *PWRMTR CAL*.
- 35** Press *LOSS/SENSR LISTS*, *CAL FACTOR SENSOR B*. Repeat Step 10 to build a calibration factor sensor table for the HP 8481A power sensor.
- 36** Press *DONE* to exit the sensor calibration factor entries menu.
- 37** To select the HP 8481A power sensor, press *USE SENSOR B*.
- 38** Press *RETURN*, *TAKE CAL SWEEP* to start the power meter calibration.

**Test Port 1 Input Frequency Response from
3 GHz to 6 GHz**

- 39 When the analyzer finishes the calibration sweep, connect the equipment as shown in Figure 4-15.

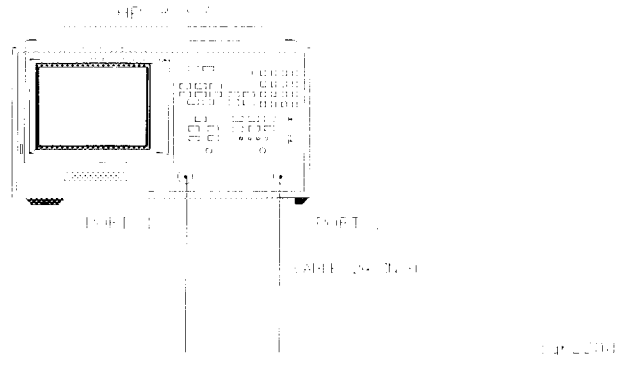

Figure 4-15. Setup for Test Port 1 Input Frequency Response

- 40 Press MEAS, *INPUT PORTS*, A.
- 41 Press MARKER, *MARKER 1*, MARKER FCTN, *MARKER MODE MENU*, MKR SEARCH, *SEARCH:MIN* to put marker 1 at the minimum magnitude location of the trace.
- 42 Press MARKER, *MARKER 2*, MARKER FCTN, *MARKER MODE MENU*, MKR SEARCH, *SEARCH:MAX* to position marker 2 at the maximum magnitude location of the trace.
- 43 Write the marker 1 or marker 2 reading, whichever has the largest absolute magnitude, in the “Performance Test Record.”

**Power Meter Calibration on Test Port 1 from
3 GHz to 6 GHz**

- 44 Connect the equipment as shown in Figure 4-16.

7. Test Port Input Frequency Response

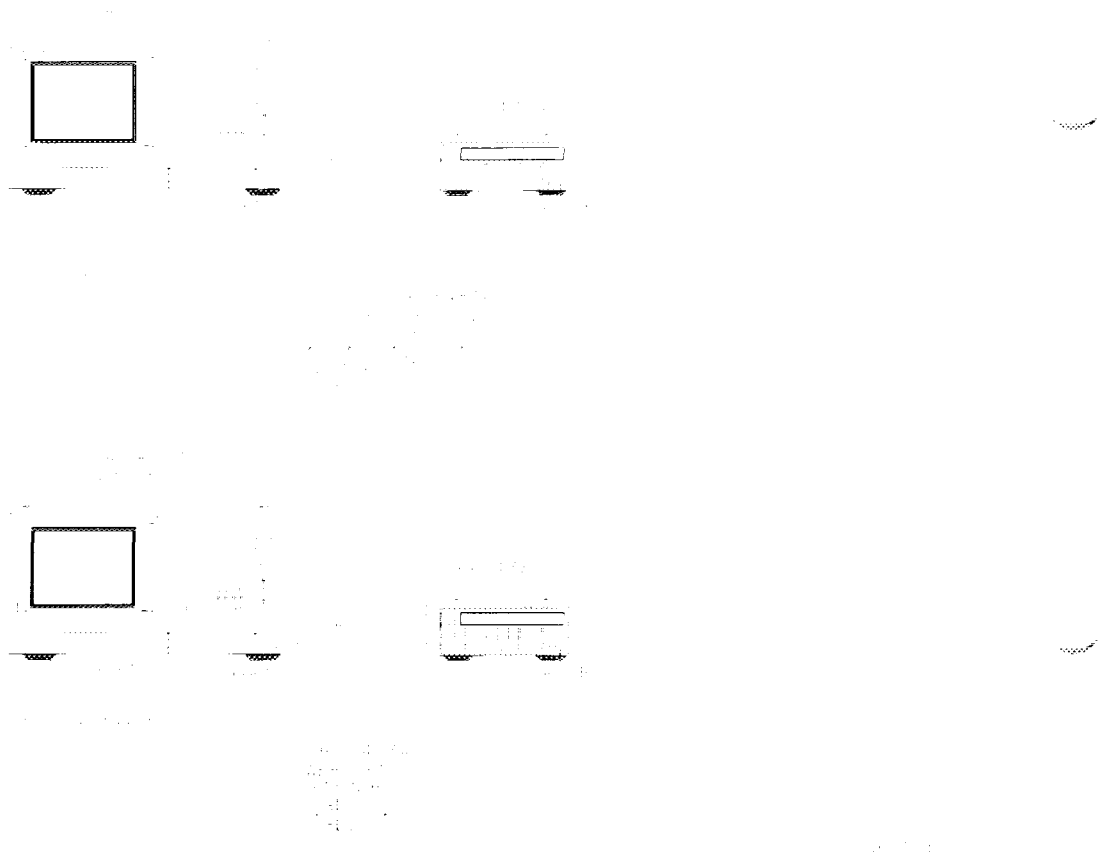

Figure 4-16. Setup for Power Meter Calibration on Test Port 1

- 45 Press MEAS, INPUT PORTS, TESTPORT 1.
- 46 Press CAL, PWRMTR CAL, ONE SWEEP, TAKE CAL SWEEP to start the power meter calibration for output test port 1.

Test Port 2 Input Frequency Response from 3 GHz to 6 GHz

- 47 When the analyzer displays the message, POWER METER CALIBRATION SWEEP DONE, connect the equipment as shown as in Figure 4-17.

7. Test Port Input Frequency Response**Figure 4-17. Test Port 2 Input Frequency Response Test Setup**

- 48** Press MEAS, *INPUT PORTS, B*.
- 49** Press MARKER, *MARKER 1, MARKER FCTN, MARKER MODE MENU, MKR SEARCH, SEARCH:MIN*.
- 50** Press MARKER, *MARKER 2, MARKER FCTN, MARKER MODE MENU, MKR SEARCH, SEARCH:MAX*.
- 51** Write the marker 1 or marker 2 reading, whichever has the largest magnitude, in the “Performance Test Record.”

In Case of Difficulty

- 1** Be sure you have used the correct power sensor for the frequency range.
- 2** Verify that the calibration factors that you have entered for the power sensors are correct.
- 3** Repeat this test with a “known good” thru cable.

8. Test Port Crosstalk

8. Test Port Crosstalk

Perform this test to verify the signal leakage between the analyzer's test ports.

**Required
Equipment**

For 50Ω Analyzers

Calibration Kit, 7 mm HP 85031B
Cable, APC-7 24-inch HP P/N 8120-4779

For 75Ω Analyzers

Calibration Kit, 75Ω, Type-N HP 85036B

Procedure

- 1 Connect the equipment as shown in Figure 4-18.

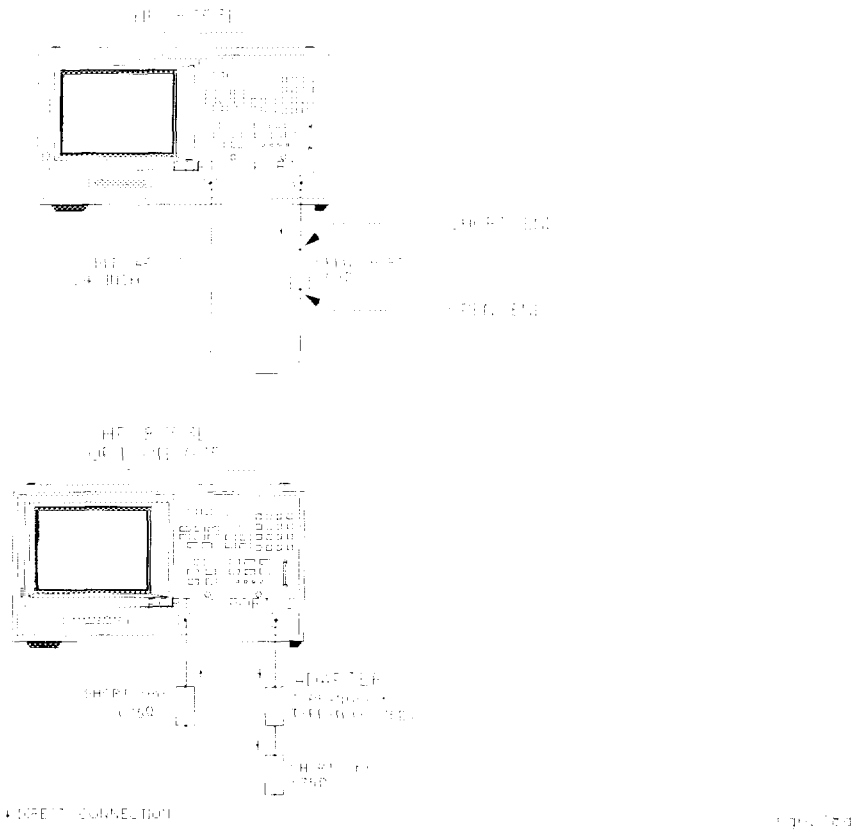

Figure 4-18. Test Port Crosstalk Test Setup

- 2 Press PRESET, MENU, POWER, 10, x1.
- 3 Press AVG, IF BW, 10, x1.

Crosstalk to Test Port 2 from 300 kHz to 3 GHz

- 4 Press START, 300, k/m, STOP, 3, G/n.
- 5 Press MEAS, Trans: E/E S21 FWD.
- 6 Press SCALE REF, REFERENCE VALUE, -100, x1.
- 7 Press MENU, TRIGGER MENU, SINGLE.
- 8 Press MARKER FCTN, MARKER MODE MENU, MKR SEARCH, SEARCH: MAX.

8. Test Port Crosstalk

- 9 Write the marker value (which appears on the analyzer display) in the "Performance Test Record."

Crosstalk to Test Port 1 from 300 kHz to 3 GHz

- 10 Press MEAS, *Trans: E/E S12 REV.*
- 11 Press MENU, *TRIGGER MENU, SINGLE.*
- 12 Press MARKER FCTN, *MARKER MODE MENU, MKR SEARCH, SEARCH: MAX.*
- 13 Write the marker value (which appears on the analyzer display) in the "Performance Test Record."
- 14 This completes the "Test Port Crosstalk" performance test if your analyzer does *not* have Option 006. Otherwise, proceed to the next section.

Crosstalk to Test Port 1 from 3 GHz to 6 GHz

- 15 Press START, 3, G/n, STOP, 6, G/n.
- 16 Press MENU, *TRIGGER MENU, SINGLE.*
- 17 Press MARKER FCTN, *MARKER MODE MENU, MKR SEARCH, SEARCH: MAX.*
- 18 Write the marker value (which appears on the analyzer display) in the "Performance Test Record."

Crosstalk to Test Port 2 from 3 GHz to 6 GHz

- 1 Press MEAS, *Trans: E/E S21 FWD.*
- 2 Press MENU, *TRIGGER MENU, SINGLE.*
- 3 Press MARKER FCTN, *MARKER MODE MENU, MKR SEARCH, SEARCH: MAX.*
- 4 Write the marker value (which appears on the analyzer display) in the "Performance Test Record."

**In Case of
Difficulty**

WARNING

These servicing instructions are for use by qualified personnel only. To avoid electrical shock, do not perform any servicing unless you are qualified to do so.

WARNING

The opening of covers or removal of parts is likely to expose dangerous voltages. Disconnect the instrument from all voltage sources while it is being opened.

WARNING

The power cord is connected to internal capacitors that may remain live for five seconds after disconnecting the plug from its power supply.

- 1** Remove the instrument top cover. Using an 8 lb-inch torque wrench, verify that *all* semi-rigid cables connected to the sampler/mixer assemblies are tight. In addition tighten any loose screws on the sampler/mixer assemblies (A4/5/6) and the pulse generator assembly (A7).
- 2** Remove the instrument bottom cover. Refer to Figure 4-19. Verify that cables W1, W31 and W32 are tight.
- 3** Repeat this test.

8. Test Port Crosstalk

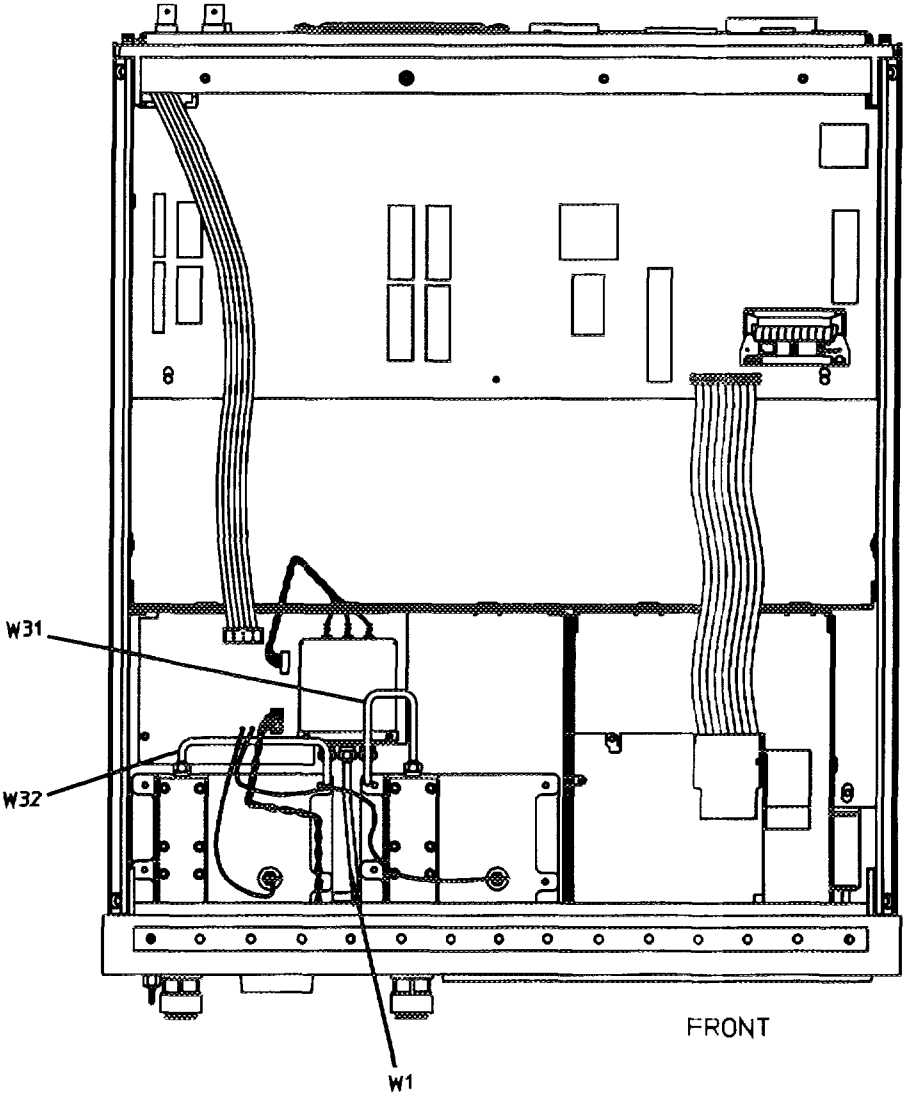

sg621fd

Figure 4-19. HP 8702D Bottom View

9. Calibration Coefficients

Perform this procedure to verify the analyzer uncorrected test port characteristics.

Required Equipment

For 50Ω Analyzers

Calibration Kit, 7 mm HP 85031B
Cable, APC-7, 24-inch HP P/N 8120-4779

For 75Ω Analyzers

Calibration Kit, Type-N HP 85036B
Cable, Type-N, 24-inch HP P/N 8120-4781

Procedure

NOTE

The crosstalk calibration coefficients are omitted in this procedure. They are covered in the "Test Port Crosstalk" performance test.

First Full 2-Port Calibration

- 1 Connect the equipment as shown in Figure 4-20.

9. Calibration Coefficients

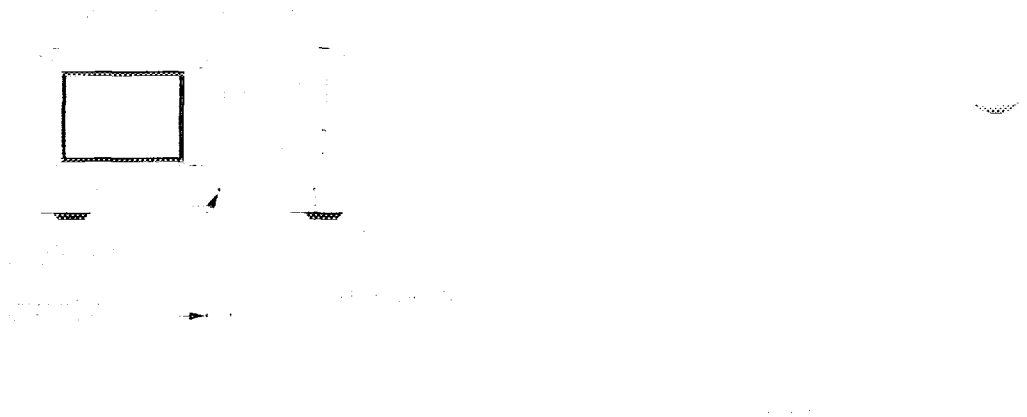

Figure 4-20. First Full 2-Port Calibration Test Setup

- 2** Press *PRESET, START, 300, k/m.*
- 3** Press *CAL, CAL KITS & STDS, SELECT CAL KIT, CAL KIT: 7mm, RETURN, RETURN, CALIBRATE MENU, FULL 2-PORT.*
- 4** Press *ISOLATION, OMIT ISOLATION, ISOLATION DONE.*
- 5** Connect the “open” end of the open/short combination (supplied in the calibration kit) to analyzer test port 1.
- 6** Press *REFLECTION, FORWARD:OPEN.*
- 7** Connect the “short” end of the open/short combination to analyzer test port 1.
- 8** Press *FORWARD:SHORT.*
- 9** Replace the open/short combination with the 50 ohm termination (supplied in the calibration kit).
- 10** Press *FORWARD:LOAD.*
- 11** Connect the “open” end of the open/short combination to the reference test port 2.
- 12** Press *REVERSE:OPEN.*
- 13** Connect the “short” end of the open/short combination to the reference test port 2.
- 14** Press *REVERSE:SHORT.*

- 15** Connect the 50 ohm termination to the reference test port 2.
- 16** Press *REVERSE: LOAD*.
- 17** At the prompt, PRESS 'DONE' IF FINISHED WITH STD(s), press *STANDARDS DONE*.

Wait for the message, *COMPUTING CAL COEFFICIENTS*, to disappear from the analyzer display before proceeding to the next step.

- 18** Connect the equipment as shown in Figure 4-21.

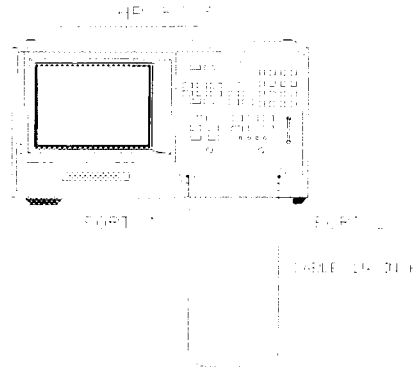

Figure 4-21. Transmission Calibration Test Setup

- 19** Press *TRANSMISSION, FWD TRANS THRU*.
- 20** When the analyzer finishes the measurement, press *FWD MATCH THRU*.
- 21** When the analyzer finishes the measurement, press *REV TRANS THRU*.
- 22** After the analyzer finishes the measurement, press *REV MATCH THRU*.
- 23** After the analyzer finishes the measurement, press *STANDARDS DONE, DONE 2-PORT CAL*.

Directivity (Forward) Calibration Coefficient

- 24** Press *SYSTEM, SERVICE MENU, TESTS, 32, x1, EXECUTE TEST*.
- 25** When the analyzer finishes the test, press *MARKER*.
- 26** Using the front panel knob, locate the maximum value of the data trace for the 300 kHz to 1.3 GHz frequency range.

9. Calibration Coefficients

- 27 Write the maximum value in the “Performance Test Record.”
- 28 Repeat the previous two steps for the other frequency range(s) listed on the “Performance Test Record.”

Source Match (Forward) Calibration Coefficient

- 29 Press SYSTEM, *SERVICE MENU*, TESTS, 33, x1, EXECUTE TEST.
- 30 When the analyzer finishes the test, repeat Step 25 through Step 28.

Transmission Tracking (Forward) Calibration Coefficient

- 31 Press SYSTEM, *SERVICE MENU*, TESTS, 37, x1, EXECUTE TEST.
- 32 When the analyzer finishes the test, repeat Step 25 through Step 28.

Reflection Tracking (Forward) Calibration Coefficient

- 33 Press SYSTEM, *SERVICE MENU*, TESTS, 34, x1, EXECUTE TEST.
- 34 When the analyzer finishes the test, repeat Step 25 through Step 28.

Load Match (Reverse) Calibration Coefficient

- 35 Press SYSTEM, *SERVICE MENU*, TESTS, 42, x1, EXECUTE TEST.
- 36 When the analyzer finishes the test, repeat Step 25 through Step 28.

Transmission Tracking (Reverse) Calibration Coefficient

- 37 Press SYSTEM, *SERVICE MENU*, TESTS, 43, x1, EXECUTE TEST.
- 38 When the analyzer finishes the test, repeat Step 25 through Step 28.

Second Full 2-Port Calibration

- 39 Connect the equipment as shown in Figure 4-22.



Figure 4-22. Second Full 2-Port Calibration Test Setup

- 40** Press *PRESET, START, 300, k/m*.
- 41** Press *CAL, CAL KITS & STDS, SELECT CAL KIT, CAL KIT: 7mm, RETURN, RETURN, CALIBRATE MENU, FULL 2-PORT*.
- 42** Press *ISOLATION, OMIT ISOLATION, ISOLATION DONE*.
- 43** Connect the “open” end of the open/short combination (supplied in the calibration kit) to reference test port 1.
- 44** Press *REFLECTION, FORWARD:OPEN*.
- 45** Connect the “short” end of the open/short combination to reference test port 1.
- 46** Press *FORWARD:SHORT*.
- 47** Replace the open/short combination with the 50 ohm termination (supplied in the calibration kit).
- 48** Press *FORWARD:LOAD*.
- 49** Connect the “open” end of the open/short combination to the analyzer test port 2.
- 50** Press *REVERSE:OPEN*.
- 51** Connect the “short” end of the open/short combination to the analyzer test port 2.
- 52** Press *REVERSE: SHORT*.

9. Calibration Coefficients

- 53 Connect the 50 ohm termination to the analyzer test port 2.
- 54 Press *REVERSE LOAD*.
- 55 When the analyzer displays, PRESS 'DONE' IF FINISHED WITH STD(s), press *STANDARDS DONE*.

Wait for the message, *COMPUTING CAL COEFFICIENTS*, to disappear from the analyzer display before proceeding to the next step.
- 56 Connect the equipment as shown in Figure 4-23.

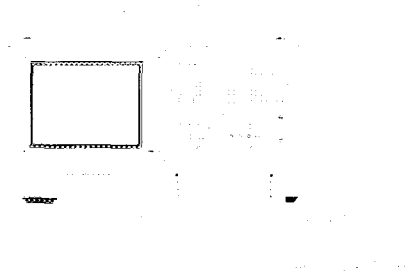

Figure 4-23. Transmission Calibration Test Setup

- 57 Press *TRANSMISSION, FWD TRANS THRU*.
- 58 When the analyzer finishes the measurement, press *FWD MATCH THRU*.
- 59 When the analyzer finishes the measurement, press *REV TRANS THRU*.
- 60 When the analyzer finishes the measurement, press *REV MATCH THRU*.
- 61 When the analyzer displays, PRESS 'DONE' IF FINISHED WITH STD(s), press *STANDARDS DONE, DONE 2-PORT CAL*.

Load Match (Forward) Calibration Coefficient

- 62 Press *SYSTEM, SERVICE MENU, TESTS, 36, x1, EXECUTE TEST*.
- 63 When the test is done, press *MARKER, MARKER 1*.
- 64 Using the front panel knob, locate the maximum value of the data trace for the 300 kHz to 1.3 GHz frequency range.

- 65 Write the maximum value on the "Performance Test Record."
- 66 Repeat the previous three steps for the other frequency range(s) listed on the "Performance Test Record."

Directivity (Reverse) Calibration Coefficient

- 67 Press SYSTEM, SERVICE MENU, TESTS, 38, x1, EXECUTE TEST.
- 68 When the analyzer finishes the test, repeat Step 63 through Step 66.

Source Match (Reverse) Calibration Coefficient

- 69 Press SYSTEM, SERVICE MENU, TESTS, 39, x1, EXECUTE TEST.
- 70 When the analyzer finishes the test, repeat Step 63 through Step 66.

Reflection Tracking (Reverse) Calibration Coefficient

- 71 Press SYSTEM, SERVICE MENU, TESTS, 40, x1, EXECUTE TEST.
- 72 When the analyzer finishes the test, repeat Step 63 through Step 66.

10. System Trace Noise (Only for Analyzers without Option 006)

10. System Trace Noise (Only for Analyzers without Option 006)

Perform this test to measure the system trace noise at a designated frequency in both the A/R and B/R ratioed measurements.

Required Equipment

For 50Ω Analyzers

Cable, APC-7, 24-inch HP P/N 8120-4779

For 75Ω Analyzers

Cable, 75Ω, Type-N 24-inch HP P/N 8120-2408

Procedure

- 1 Connect the equipment as shown in Figure 4-24.

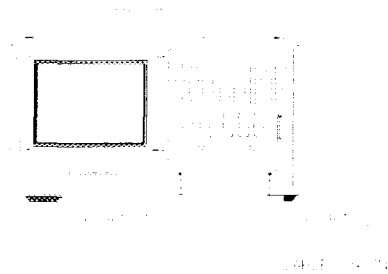

Figure 4-24. System Trace Noise Test Setup

- 2 Press PRESET, MENU, POWER, 5, x1.
- 3 Press RETURN, CW FREQ, 3, G/n, NUMBER of POINTS, 1601, x1.
- 4 Press MARKER FCTN, MARKER MODE MENU, STATS ON to activate the instrument's statistic feature.

10. System Trace Noise (Only for Analyzers without Option 006)***System Trace Noise for A/R Magnitude***

- 5** Press MEAS, *Trans: E/E S12 REV.*
- 6** Press MENU, *TRIGGER MENU, NUMBER of GROUPS, 5, x1.*
- 7** When the analyzer displays the “H1d” annotation, press SCALE REF, *AUTO SCALE.*
- 8** Write the s.dev (standard deviation) value, which appears on the analyzer display, on the “Performance Test Record.”

System Trace Noise for A/R Phase

- 9** Press FORMAT, *PHASE.*
- 10** Press MENU, *TRIGGER MENU, NUMBER of GROUPS, 5, x1.*
- 11** When the analyzer finishes the number of sweeps, press SCALE REF, *AUTO SCALE.*
- 12** Write the s.dev (standard deviation) value on the “Performance Test Record.”

System Trace Noise for B/R Magnitude

- 13** Press MEAS, *Trans: E/E S21 FWD.*
- 14** Press MENU, *TRIGGER MENU, NUMBER of GROUPS, 5, x1.*
- 15** When the analyzer finishes the number of sweeps, press SCALE REF, *AUTO SCALE.*
- 16** Write the s.dev (standard deviation) value on the “Performance Test Record.”

System Trace Noise for B/R Phase

- 17** Press FORMAT, *PHASE.*
- 18** Press MENU, *TRIGGER MENU, NUMBER of GROUPS, 5, x1.*
- 19** When the analyzer finishes the number of sweeps, press SCALE REF, *AUTO SCALE.*
- 20** Write the s.dev (standard deviation) value on the “Performance Test Record.”

**In Case of
Difficulty**

- 1** Perform the “ADC Offset Correction Constants” procedure, located in the “Adjustments and Correction Constants” chapter of the *HP 8753D Service Guide.*
- 2** Repeat this performance test.
- 3** Suspect the A10 Digital IF board assembly if the analyzer still fails the test.

11. System Trace Noise (Only for Analyzers with Option 006)

11. System Trace Noise (Only for Analyzers with Option 006)

Perform this test to measure the system trace noise at designated CW frequencies in both the A/R and B/R ratioed measurements.

Required Equipment

Cable, APC-7, 24-inch HP P/N 8120-4779

Procedure

- 1 Connect the equipment as shown in Figure 4-25.

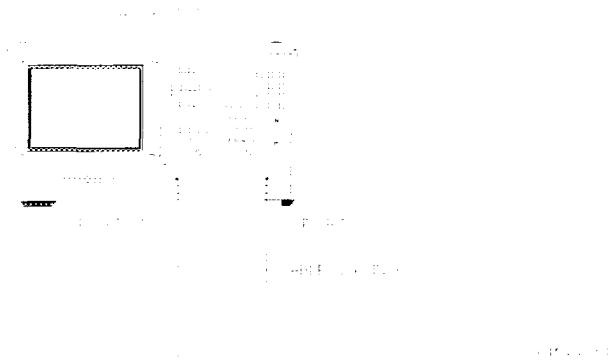

Figure 4-25. System Trace Noise Test Setup

- 2 Press PRESET, MENU, *POWER*, 5, x1, RETURN, *NUMBER of POINTS*, 1601, x1.
- 3 Press MARKER FCTN, *MARKER MODE MENU*, *STATS ON* to activate the instrument's statistic feature.

System Trace Noise for A/R Magnitude from 30 kHz to 3 GHz

- 4 Press MEAS, *Trans: E/E S12 REV*.
- 5 Press MENU, *CW FREQ*, 3, G/n, *TRIGGER MENU*, *NUMBER of GROUPS*, 5, x1.

11. System Trace Noise (Only for Analyzers with Option 006)

- 6 When the analyzer finishes the number of sweeps, press SCALE REF, *AUTO SCALE*.
- 7 Write the s.dev (standard deviation) value shown, which appears on the analyzer display, on the "Performance Test Record."

System Trace Noise for A/R Magnitude from 3 GHz to 6 GHz

- 8 Press MENU, *CW FREQ*, 6, G/n, *TRIGGER MENU*, *NUMBER of GROUPS*, 5, x1.
- 9 When the analyzer finishes the number of sweeps, press SCALE REF, *AUTO SCALE*.
- 10 Write the s.dev (standard deviation) value, which appears on the analyzer display, on the "Performance Test Record."

System Trace Noise for A/R Phase from 3 GHz to 6 GHz

- 11 Press FORMAT, *PHASE*.
- 12 Press MENU, *TRIGGER MENU*, *NUMBER of GROUPS*, 5, x1.
- 13 When the analyzer finishes the number of sweeps, press SCALE REF, *AUTO SCALE*.
- 14 Write the s.dev (standard deviation) value, which appears on the analyzer display, on the "Performance Test Record."

System Trace Noise for A/R Phase from 30 kHz to 3 GHz

- 15 Press MENU, *CW FREQ*, 3, G/n, *TRIGGER MENU*, *NUMBER of GROUPS*, 5, x1.
- 16 When the analyzer finishes the number of sweeps, press SCALE REF, *AUTO SCALE*.
- 17 Write the s.dev (standard deviation) value, which appears on the analyzer display, on the "Performance Test Record."

System Trace Noise for B/R Magnitude from 30 kHz to 3 GHz

- 18 Press MEAS, *Trans: E/E S21 FWD*, MENU, *TRIGGER MENU*, *NUMBER of GROUPS*, 5, x1.
- 19 When the analyzer finishes the number of sweeps, press SCALE REF, *AUTO SCALE*.
- 20 Write the s.dev (standard deviation) value, which appears on the analyzer display, on the "Performance Test Record."

System Trace Noise for B/R Magnitude from 3 GHz to 6 GHz

- 21 Press MENU, *CW FREQ*, 6, G/n, *TRIGGER MENU*, *NUMBER of GROUPS*, 5, x1.

11. System Trace Noise (Only for Analyzers with Option 006)

- 22 When the analyzer finishes the number of sweeps, press SCALE REF, *AUTO SCALE*.
- 23 Write the s.dev (standard deviation) value, which appears on the analyzer display, on the "Performance Test Record."

System Trace Noise for B/R Phase from 3 GHz to 6 GHz

- 24 Press FORMAT, *PHASE*, MENU, *TRIGGER MENU*, *NUMBER of GROUPS*, 5, x1.
- 25 When the analyzer finishes the number of sweeps, press SCALE REF, *AUTO SCALE*.
- 26 Write the s.dev (standard deviation) value, which appears on the analyzer display, on the "Performance Test Record."

System Trace Noise for B/R Phase from 30 kHz to 3 GHz

- 27 Press MENU, *CWFREQ*, 3, G/n, *TRIGGER MENU*, *NUMBER of GROUPS*, 5, x1.
- 28 When the analyzer finishes the number of sweeps, press SCALE REF, *AUTO SCALE*.
- 29 Write the s.dev (standard deviation) value, which appears on the analyzer display, on the "Performance Test Record."

**In Case of
Difficulty**

- 1 Perform the "ADC Offset Correction Constants" procedure, located in the "Adjustments and Correction Constants" chapter of the *HP 8753D Service Guide*.
- 2 Repeat this performance test.
- 3 Suspect the A10 Digital IF board assembly if the analyzer still fails the test.

12. Test Port Input Impedance

Perform this test to measure the return loss of each input test port.

Required Equipment

For 50Ω Analyzers

Cable, APC-7, 24-inch HP P/N 8120-4779
 Calibration Kit, 7 mm HP 85031B

For 75Ω Analyzers

Cable, 75Ω, Type-N, 24-inch HP P/N 8120-2408
 Calibration Kit, 75Ω, Type-N HP 85036B

Procedure

- 1 Connect the equipment as shown in Figure 4-26.

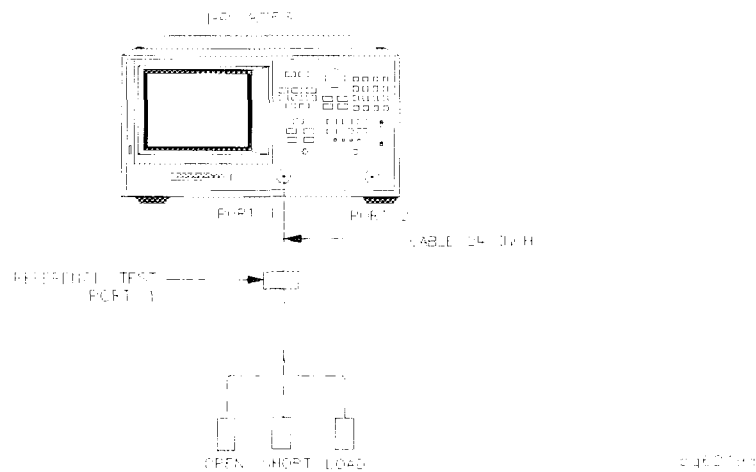

Figure 4-26. S11 1-Port Cal Test Setup

- 2 Press PRESET, MENU, *NUMBER of POINTS*, 1601, x1.
- 3 *Only for analyzers without Option 006:* Press START, 50, k/m.

12. Test Port Input Impedance

- 4 Press *CAL*, *CAL KIT & STDS*, *SELECT CAL KIT* and select the appropriate calibration kit:
 - If your analyzer is 50Ω , press *CAL KIT: 7mm*.
 - If your analyzer is 75Ω , press *CAL KIT: N 75W*.
- 5 Press *RETURN*, *RETURN*, *CALIBRATE MENU*, *S11 1-PORT*.
- 6 Connect an open to reference test port 1, as shown in Figure 4-26.
- 7 Press *FORWARD: OPEN*.
- 8 When the analyzer displays the prompt, *CONNECT STD THEN PRESS KEY TO MEASURE*, connect a short to reference test port 1.
- 9 Press *FORWARD: SHORT*.
- 10 At the prompt, connect a load to reference test port 1.
- 11 Press *FORWARD: LOAD*.
- 12 When the analyzer displays, ' *DONE* ' *IF FINISHED WITH CAL*, press *DONE 1-PORT CAL*.
- 13 Press *SAVE/RECALL*, *SAVE STATE*.
- 14 Connect the equipment as shown in Figure 4-27.

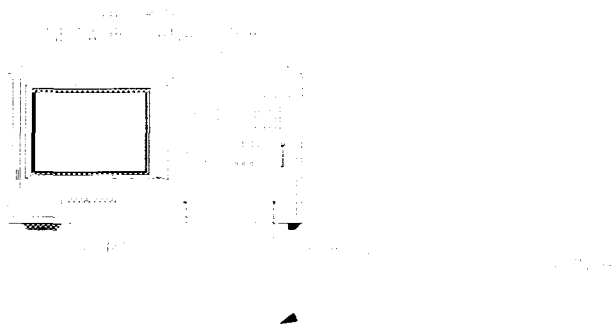

Figure 4-27. Test Port 2 Input Impedance Test Setup

- 15 Press *MARKER* to turn the analyzer's marker 1 on. Use the front panel knob to locate the maximum value of the data trace for each of the frequency ranges listed in the "Performance Test Record."

- 16** Write these maximum values on the “Performance Test Record.”
- 17** Connect the equipment as shown in Figure 4-28.

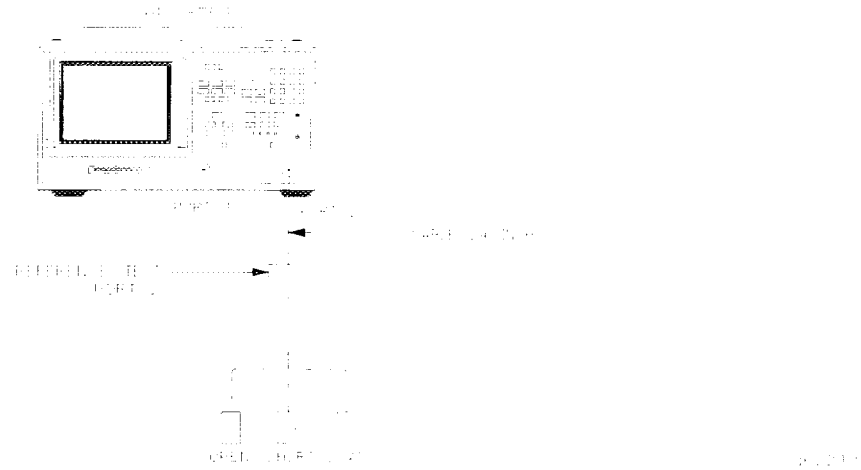

Figure 4-28. S22 1-Port Cal Test Setup

- 18** Press **CAL**, *CALIBRATE MENU*, *S22 1-PORT*.
- 19** At the prompt, connect an open to reference test port 2, as shown in Figure 4-28.
- 20** Press *REVERSE: OPEN*.
- 21** When the analyzer displays the prompt, *CONNECT STD THEN PRESS KEY TO MEASURE*, connect a short to reference test port 2.
- 22** Press *REVERSE: SHORT*.
- 23** At the prompt, connect a load to reference test port 2.
- 24** Press *REVERSE: LOAD*.
- 25** When the analyzer displays, 'DONE' IF FINISHED WITH CAL, press *DONE 1-PORT CAL*.
- 26** Press *SAVE/RECALL*, *SAVE STATE* to save the 1-Port calibration.
- 27** Connect the equipment as shown in Figure 4-29.

12. Test Port Input Impedance

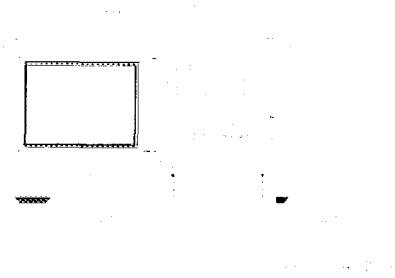

Figure 4-29. Test Port 1 Input Impedance Test Setup

- 28** Press MARKER to activate the analyzer's marker 1. Use the front panel knob to locate the maximum value of the data trace for each of the frequency ranges listed in the "Performance Test Record."
- 29** Write the maximum values on the "Performance Test Record."

In Case of Difficulty

- 1** Suspect the A10 digital IF board assembly if the analyzer fails *both* test port tests.
- 2** Refer to the *HP 8753D Service Guide* for more troubleshooting information.

13. Test Port Receiver Magnitude Dynamic Accuracy

Perform this procedure to measure the magnitude dynamic accuracy for each input test port.

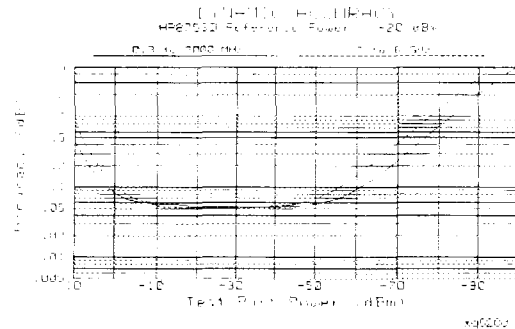

Figure 4-30. Receiver Magnitude Dynamic Accuracy

Required Equipment

Measuring Receiver	HP 8902A
Step Attenuator, 110 dB	HP 8496A
Adapter (2), APC-7 to Type-N (f)	HP 118524A
Adapter, Type-N (m) to Type-N (m)	HP P/N 1250-1528
2-Way Power Splitter, 50 Ω	HP 11667A
Cable (3), 50 Ω , Type-N, 24-inch	HP P/N 8120-4781

Additional Required Equipment for 75 Ω Analyzers

Minimum Loss Pad (2), 50 Ω to 75 Ω	HP 11852B
--------------------------------------------------	-----------

Procedure

Test Port 2 Magnitude Dynamic Accuracy

- 1 On the HP 8902A:
 - a Press the blue shift key and INSTR PRESET, CLEAR.
 - b Press the yellow shift key and TUNED RF LEVEL.
 - c Press LOG/LIN to have the HP 8902A displayed linear readings (dBm).
 - d Press 32.1, SPCL.
- 2 Set the HP 8496A to 10 dB.

13. Test Port Receiver Magnitude Dynamic Accuracy

- 3** On the HP 8702D:
 - a** Press PRESET, MENU, *CW FREQ*, 30, M/ μ .
 - b** Press *NUMBER of POINTS*, 51, x1.
 - c** Press AVG, *IF BW*, 10, x1.
- 4** Connect the equipment as shown in Figure 4-31.

13. Test Port Receiver Magnitude Dynamic Accuracy

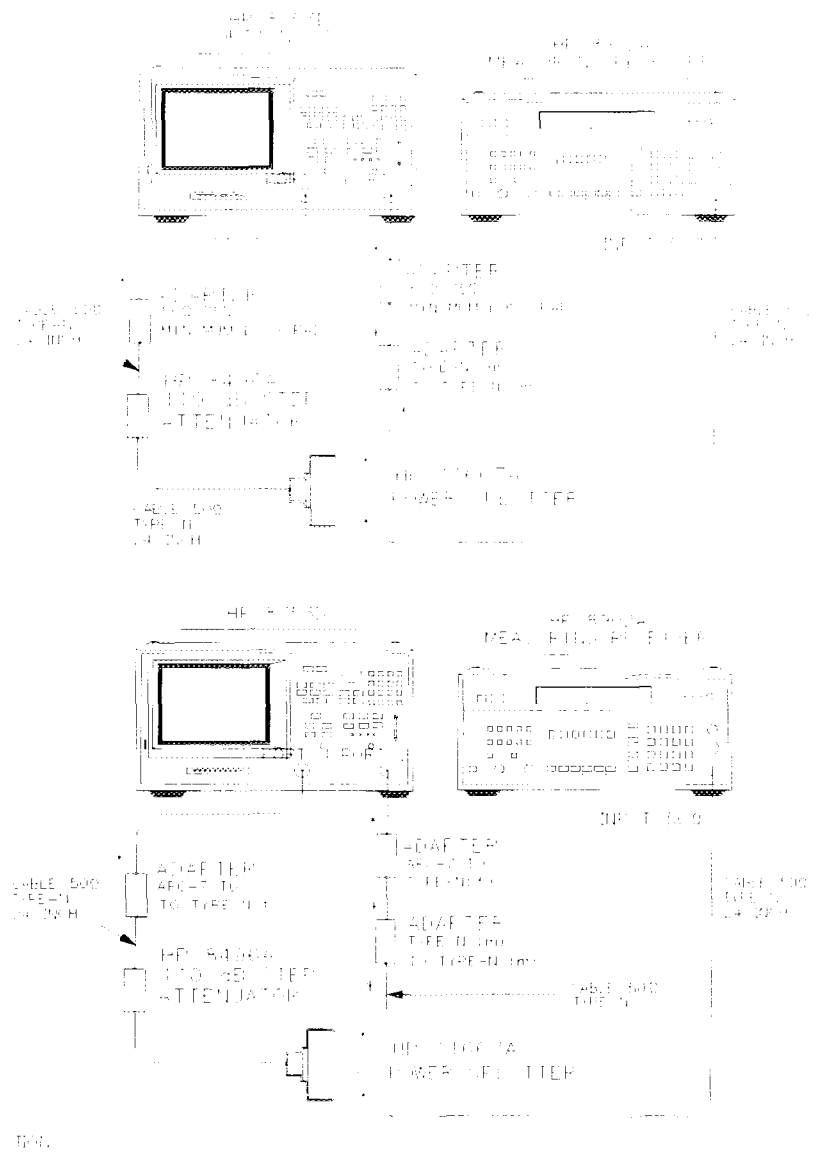

Figure 4-31. Test Port 2 Dynamic Accuracy Test Setup

13. Test Port Receiver Magnitude Dynamic Accuracy

- 5 On the HP 8702D:
 - a Press MEAS, *INPUT PORTS*, *B*, MENU, *POWER*, -4, x1.
 - b Using the analyzer front panel knob, adjust the test port power for a reading of -20.000 dBm on the HP 8902A.
 - c Wait for the reading to stabilize.

NOTE

Ignore the *UNCAL* displayed on the HP 8902A. This indicates that you are making an approximate power level measurement. However, this is *not* a concern because you will be making a relative power measurement.

- 6 On the HP 8902A, press the blue shift key and SET REF.
 - If the HP 8902A has drifted, adjust the analyzer front panel knob for a power reading of 0.000 dBm on the HP 8902A.
- 7 On the HP 8702D:
 - a Press CAL, *CALIBRATE MENU*, *RESPONSE*, *THRU*.
 - b After the analyzer finishes the measurement, press *DONE*: *RESPONSE*.
 - c Press SAVE/RECALL, *SAVE STATE*.
 - d Press MARKER FCTN, *MARKER MODE MENU*, *STATS ON*.
- 8 Set the HP 8496A to 0 dB.
- 9 On the HP 8702D, press MENU, *TRIGGER MENU*, *SINGLE*.
- 10 Write the mean value (which appears on the analyzer's display) in the "Test Port" column of the "Performance Test Record."
- 11 Write the HP 8902A readout in the "8902A" column of the "Performance Test Record."
- 12 Calculate the difference between the "Test Port 2" and the "8902A".
- 13 Take the absolute value of the calculated difference, and enter the result in the "Calculated Value" column of the "Performance Test Record."
- 14 Set the HP 8496A to the other attenuation settings listed in the "Performance Test Record," while repeating Step 9 through Step 13.

13. Test Port Receiver Magnitude Dynamic Accuracy**NOTE**

When the HP 8902A displays the "RECAL" annunciation, press CALIBRATE.

Test Port 1 Magnitude Dynamic Accuracy

- 15** Set the HP 8496A to 10 dB.
- 16** On the HP 8702D, press *CONTINUOUS*, *MEAS*, *INPUT PORTS*, *TESTPORT 2*, *A*.
- 17** Connect the equipment as shown in Figure 4-32.

13. Test Port Receiver Magnitude Dynamic Accuracy

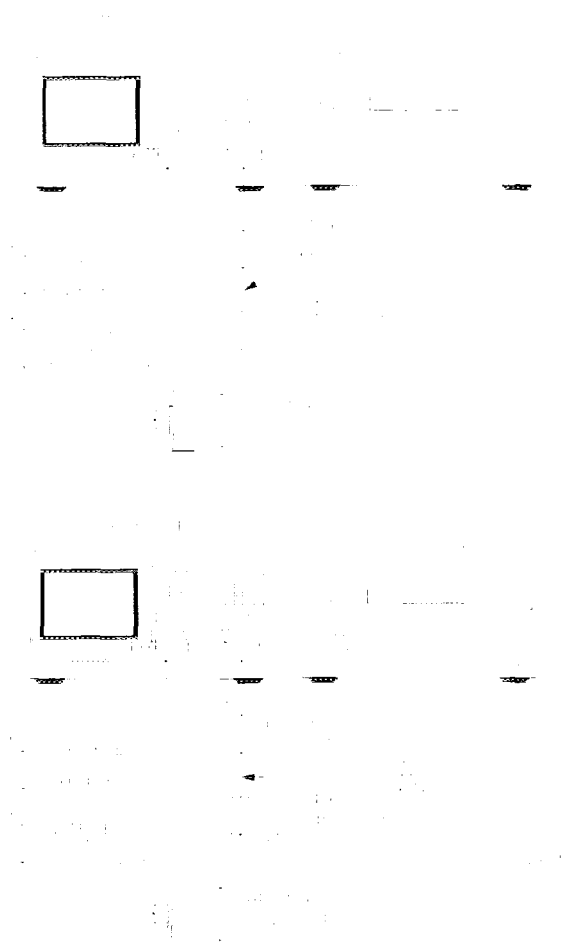

Figure 4-32. Test Port 1 Magnitude Dynamic Accuracy Test Setup

- 18** On the HP 8702D:
 - a** Press MENU, *POWER*.
 - b** Using the analyzer front panel knob, adjust the test port power for a reading of 0.000 dB on the HP 8902A.
 - c** Wait for the reading to stabilize.

13. Test Port Receiver Magnitude Dynamic Accuracy

- 19** On the HP 8902A, press the blue shift key and SET REF.
- 20** On the HP 8702D:
 - a** Press CAL, *CALIBRATE MENU, RESPONSE, THRU*.
 - b** After the analyzer finishes the measurement, press *DONE: RESPONSE*.
 - c** Press SAVE/RECALL, *SAVE STATE*.
- 21** Set the HP 8496A to 0 dB.
- 22** On the HP 8702D, press MENU, *TRIGGER MENU, SINGLE*.
- 23** Write the mean value in the "Test Port" column of the "Performance Test Record."
- 24** Write the HP 8902A readout in the "8902A" column of the "Performance Test Record."
- 25** Calculate the difference between the "Test Port 1" and the "8902A".
- 26** Take the absolute value of the calculated difference and enter the result in the "Calculated Value" column of the "Performance Test Record."
- 27** Set the HP 8496A to the other attenuation settings listed in the "Performance Test Record," while repeating Step 22 through Step 26.

NOTE

When the HP 8902A displays the "RECAL" annunciation, press CALIBRATE.

13. Test Port Receiver Magnitude Dynamic Accuracy

**In Case of
Difficulty**

- 1** If the analyzer fails the test at *all* power levels, be sure you followed the recommended attenuator settings as listed in the "Performance Test Record." Repeat this performance test.
- 2** If both test port measured values are out of specifications:
 - a** Recalibrate the HP 8902A.
 - b** Press CLEAR on the HP 8902A.
 - c** Repeat this performance test.
 - d** Press CALIBRATE when either "ERROR 32" or "RECAL" is shown on the measuring receiver display.
- 3** If the analyzer fails either test port 2 or test port 1 dynamic accuracy at lower power levels:
 - a** Perform the "IF Amplifier Correction Constants" and "ADC Offset Correction Constants" procedures (located in the "Adjustments and Correction Constants" chapter of the *HP 8753D Service Guide*).
 - b** Repeat this performance test.
 - c** If it still fails, replace the A10 Digital IF assembly.
 - d** Repeat the two adjustment procedures mentioned in this step and then repeat this performance test.

14. Test Port Receiver Phase Dynamic Accuracy

Perform this test to measure phase dynamic accuracy of each input test port.

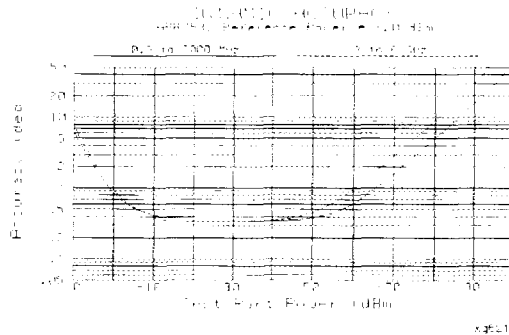

Figure 4-33. Dynamic Accuracy (Phase)

Procedure

Test Port 2 Phase Dynamic Accuracy

- 1 Refer to the “Test Port Receiver Magnitude Dynamic Accuracy” portion of the “Performance Test Record,” for the values in the “Calculated Value” column.
- 2 Copy the values in the “Magnitude Value” column to the “Calculated Value” column of the “Test Port Receiver Phase Dynamic Accuracy” portion of the “Performance Test Record.”
- 3 For every test port input power level, calculate “A” using the following formula:

$$A = 10 \left(\frac{\text{Calculated Value}}{20} \right)$$

- 4 Write the result in the “A” column of the “Performance Test Record.”
- 5 For every test port input power level, calculate “B” using the following formula:

$$B = I - A$$

- 6 Write the result in the “B” column of the “Performance Test Record.”

14. Test Port Receiver Phase Dynamic Accuracy

- 7 For every test port input power level, calculate the receiver phase dynamic accuracy using the following formula:

$$\text{Phase Dynamic Accuracy} = \text{SIN}^{-1}(B)$$

- 8 Write the value in the “Results Value” column of the “Performance Test Record.”

Test Port 1 Phase Dynamic Accuracy

- 9 Repeat Step 1 through Step 8.

15. Test Port Receiver Magnitude Compression

Perform this test to verify the compression/expansion magnitude levels of the analyzer's test port receiver samplers.

Required Equipment

For 50Ω Analyzers

Cable, APC-7, 24-inch HP P/N 8120-4779

For 75Ω Analyzers

Cable, 75Ω, Type-N, 24-inch HP P/N 8120-2408

Procedure

Test Port 2 Magnitude Compression

- 1 Connect the equipment as shown in Figure 4-34.

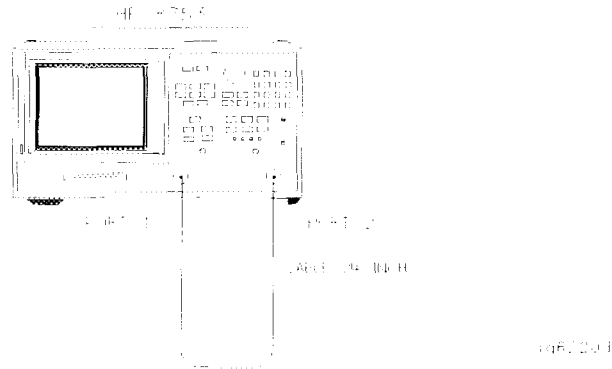

Figure 4-34. Test Port Magnitude Compression Test Setup

- 2 Press PRESET, MEAS, *Trans: E/E S21 FWD*.
- 3 Press AVG, *IF BW, 10, x1*.
- 4 Press MENU, *CW FREQ, 50, M/μ*.
- 5 Press *SWEEP TYPE MENU, POWER SWEEP, START, -10, x1*.
- 6 Press MENU, *TRIGGER MENU, SINGLE*.
- 7 At the end of the sweep, press SCALE REF, *AUTO SCALE*.
- 8 Press MARKER FCTN, *MARKER MODE MENU, MKR SEARCH, SEARCH: MAX*.

15. Test Port Receiver Magnitude Compression

- 9 Press MARKER, *MARKER 2*, MARKER FCTN, *MARKER MODE MENU*, MKR SEARCH, SEARCH: MIN.
- 10 Press MARKER, Δ MODE MENU, Δ REF= 1.
- 11 Write the absolute value of the marker 2 reading in the "Performance Test Record."
- 12 Press MENU, CW FREQ, 1, G/n.
- 13 Press TRIGGER MENU, SINGLE.
- 14 At the end of the sweep, press SCALE REF, AUTO SCALE.
- 15 Press MARKER, Δ MODE MENU, Δ REF=1, MARKER FCTN, *MARKER MODE MENU*, MKR SEARCH, SEARCH: MAX.
- 16 Press MARKER, *MARKER 2*, MARKER FCTN, *MARKER MODE MENU*, MKR SEARCH, SEARCH: MIN.
- 17 Write the absolute value of marker 2 in the "Performance Test Record."
- 18 Repeat Step 12 through Step 17 for the other frequencies listed for Port 2 on the "Performance Test Record."

Test Port 1 Magnitude Compression

- 19 Press MEAS, *Trans: E/E S12 REV*.
- 20 Press MENU, CW FREQ, 50, M/ μ .
- 21 Press TRIGGER MENU, SINGLE.
- 22 At the end of the sweep, press SCALE REF, AUTO SCALE.
- 23 Press MARKER, Δ MODE MENU, Δ REF= 1, MARKER FCTN, *MARKER MODE MENU*, MKR SEARCH, SEARCH: MAX.
- 24 Press MARKER, *MARKER 2*, MARKER FCTN, *MARKER MODE MENU*, MKR SEARCH, SEARCH: MIN.
- 25 Write the absolute value of the marker 2 reading in the "Measured Value" column of the "Performance Test Record."
- 26 Repeat Step 19 through Step 25 for the other CW frequencies listed for Port 1 in the "Performance Test Record."

**In Case of
Difficulty**

WARNING

These servicing instructions are for use by qualified personnel only. To avoid electrical shock, do not perform any servicing unless you are qualified to do so.

WARNING

The opening of covers or removal of parts is likely to expose dangerous voltages. Disconnect the instrument from all voltage sources while it is being opened.

WARNING

The power cord is connected to internal capacitors that may remain live for five seconds after disconnecting the plug from its power supply.

- 1** If the analyzer fails "Test Port 2 Magnitude Compression":
 - a** Repeat this test.
 - b** Replace the A6 B sampler assembly if the analyzer still fails the test.
- 2** If the analyzer fails "Test Port 1 Magnitude Compression":
 - a** Repeat this test.
 - b** Replace the A5 A sampler assembly if the analyzer still fails the test.

16. Test Port Receiver Phase Compression

16. Test Port Receiver Phase Compression

Perform this test to verify the compression/expansion phase relationships of the analyzer's test port receiver samplers.

Required Equipment**For 50 Ω Analyzers**

Cable, APC-7, 24-inch HP P/N 8120-4779

For 75 Ω Analyzers

Cable, 75 Ω , Type-N, 24-inch HP P/N 8120-2408

Procedure**Test Port 2 Phase Compression**

- 1 Connect the equipment as shown in Figure 4-35.

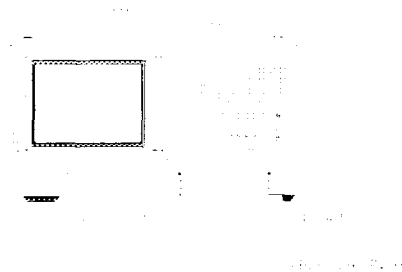

Figure 4-35. Test Port Phase Compression Test Setup

- 2 Press PRESET, MEAS, *Trans: E/E S21 FWD*, FORMAT, PHASE.
- 3 Press AVG, IF BW, 10, x1.
- 4 Press MENU, SWEEP TYPE MENU, POWER SWEEP, START. -10, x1.
- 5 Press MENU, CW FREQ, 50, M/ μ .
- 6 Press MENU, TRIGGER MENU, SINGLE.
- 7 At the end of the sweep, press SCALE REF, AUTO SCALE.
- 8 Press MARKER FCTN, MARKER MODE MENU, MKR SEARCH, SEARCH: MAX.

16. Test Port Receiver Phase Compression

- 9** Press MARKER, *MARKER 2*, MARKER FCTN, *MARKER MODE MENU*, MKR SEARCH, SEARCH: MIN.
- 10** Press MARKER, Δ MODE MENU, Δ REF= 1.
- 11** Write the absolute value of the marker 2 reading in the “Measured Value” column of the “Performance Test Record.”
- 12** Repeat Step 5 through Step 11 for the other CW frequencies listed for Port 2 in the “Performance Test Record.”

Test Port 1 Phase Compression

- 13** Press MEAS, *Trans: E/E S12 REV*, FORMAT, PHASE.
- 14** Press MENU, *CW FREQ*, 50, M/ μ .
- 15** Press MENU, *TRIGGER MENU*, SINGLE.
- 16** At the end of the sweep, press SCALE REF, *AUTO SCALE*.
- 17** Press MARKER, Δ MODE MENU, Δ REF= 1, MARKER FCTN, *MARKER MODE MENU*, MKR SEARCH, SEARCH: MAX.
- 18** Press MARKER, *MARKER 2*, MARKER FCTN, *MARKER MODE MENU*, MKR SEARCH, SEARCH: MIN.
- 19** Write the absolute value of the marker 2 reading in the “Measured Value” column of the “Performance Test Record.”
- 20** Repeat Step 14 through Step 19 for the other CW frequencies listed for Port 1 in the “Performance Test Record.”

16. Test Port Receiver Phase Compression

**In Case of
Difficulty**

WARNING

These servicing instructions are for use by qualified personnel only. To avoid electrical shock, do not perform any servicing unless you are qualified to do so.

WARNING

The opening of covers or removal of parts is likely to expose dangerous voltages. Disconnect the instrument from all voltage sources while it is being opened.

WARNING

The power cord is connected to internal capacitors that may remain live for five seconds after disconnecting the plug from its power supply.

-
- 1** If the analyzer fails the "Test Port 2 Phase Compression" test:
 - a** Repeat this test.
 - b** Replace the A6 B sampler assembly if analyzer still fails the test.
 - 2** If the analyzer fails the "Test Port 1 Phase Compression" test:
 - a** Repeat this test.
 - b** Replace the A5 A sampler assembly if analyzer still fails the test.

17. Test Port Output/Input Harmonics (Option 002 Analyzers without Option 006 Only)

17. Test Port Output/Input Harmonics (Option 002 Analyzers without Option 006 Only)

Perform this test to determine the spectral purity of the HP 8702D input and output test ports.

Required Equipment**For 50 Ω Analyzers**

Cable, APC-7, 24-inch HP P/N 8120-4779
Attenuator (2), 20 dB, APC-7 HP 8492A Option 020

For 75 Ω Analyzers

Minimum Loss Pad (2) HP 11852B
Cable, Type-N HP P/N 8120-2408
Attenuator (2), 20 dB, Type-N HP 8491A Option 020

Procedure**NOTE**

The test port input 3rd harmonic specifications are *better* than the test port output 3rd harmonic specifications.

Test Port Output Worst Case 2nd Harmonic

- 1 Press PRESET, MENU, *POWER*, 10, x1.
- 2 Press START, 16, M/ μ , STOP, 1.5, G/h to set the frequency range.
- 3 Press AVG, *IF BW*, 10, x1 to set the IF bandwidth to 10 Hz.
- 4 Connect the equipment as shown in Figure 4-36.

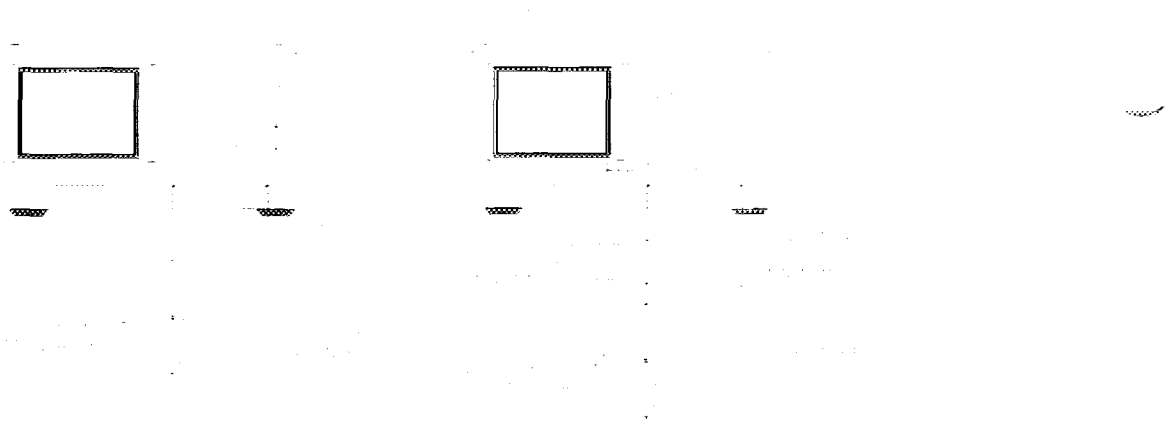
17. Test Port Output/Input Harmonics (Option 002 Analyzers without Option 006 Only)**Figure 4-36. Test Port Output Harmonics Test Setup**

- 5 Press MEAS, *Trans: E/E S12 REV, INPUT PORTS, A.*
- 6 After one sweep, press DISPLAY, *DATA→MEMORY, DATA/MEM* to normalize the trace.
- 7 Press SYSTEM, *HARMONIC MEAS, HARMONIC SECOND.*
- 8 After one sweep, press SCALE REF, *AUTO SCALE* to get a better viewing of the trace.
- 9 Press MARKER FCTN, *MARKER MODE MENU, MKR SEARCH, SEARCH MAX.*
- 10 Write the marker 1 value (which appears on the analyzer display) on the "Performance Test Record." This is the worst case test port output 2nd harmonic.

Test Port Output Worst Case 3rd Harmonic

- 11 Press STOP, 1, G/n to change the stop frequency to 1 GHz.
- 12 Press SYSTEM, *HARMONIC MEAS, HARMONIC OFF.*
- 13 After one sweep, press DISPLAY, *DATA→MEMORY, DATA/MEM* to normalize the trace.
- 14 Press SCALE REF, *AUTO SCALE, SCALE/DIV, 1, x1* to get a better viewing of the trace.
- 15 Press SYSTEM, *HARMONIC MEAS, HARMONIC THIRD.*

17. Test Port Output/Input Harmonics (Option 002 Analyzers without Option 006 Only)

- 16 After one sweep, press *SCALE REF*, *AUTO SCALE*.
- 17 Press *MARKER FCTN*, *MARKER MODE MENU*, *MKR SEARCH*, *SEARCH MAX*.
- 18 Write the marker 1 value on the “Performance Test Record.”

Port 1 Input Worst Case 2nd Harmonic

- 19 Connect the equipment as shown in Figure 4-37.

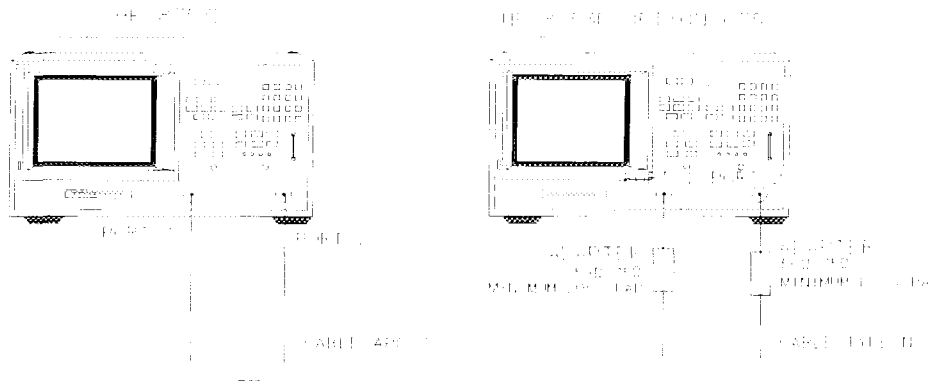
**Figure 4-37. Receiver Harmonics Test Setup**

- 20 Press *PRESET*, *MENU*, *POWER*, 8, x1.
- 21 Press *AVG*, *IF BW*, 1, 0, x1.
- 22 Press *START*, 16, M/ μ , *STOP*, 1.5, G/n to set the frequency range.
- 23 Press *MEAS*, *Trans: E/E S12 REV*, *INPUT PORTS*, A.
- 24 After one sweep, press *DISPLAY*, *DATA*→*MEMORY*, *DATA/MEM* to normalize the trace.
- 25 Press *SYSTEM*, *HARMONIC MEAS*, *HARMONIC SECOND*.
- 26 After one sweep, press *SCALE REF*, *AUTO SCALE* to get a better viewing of the trace.
- 27 Press *MARKER FCTN*, *MARKER MODE MENU*, *MKR SEARCH*, *SEARCH MAX*.
- 28 Write the marker 1 value (which appears on the analyzer display) on the “Performance Test Record.” This is the worst case port 1 input (receiver channel A) 2nd harmonic.

17. Test Port Output/Input Harmonics (Option 002 Analyzers without Option 006 Only)***Port 1 Input Worst Case 3rd Harmonic***

- 29** Press STOP, 1, G/n to change the stop frequency for measuring the receiver 3rd harmonic.
- 30** Press SYSTEM, *HARMONIC MEAS*, *HARMONIC OFF*.
- 31** After one sweep, press DISPLAY, *DATA→MEMORY*, *DATA/MEM* to normalize the trace.
- 32** Press SCALE REF, *AUTO SCALE*, *SCALE/DIV*, 1, x1 to get a better viewing of the trace.
- 33** Press SYSTEM, *HARMONIC MEAS*, *HARMONIC THIRD*.
- 34** After one sweep, press SCALE REF, *AUTO SCALE*.
- 35** Press MARKER FCTN, *MARKER MODE MENU*, *MKR SEARCH*, *SEARCH MAX*.
- 36** Write the marker 1 value on the "Performance Test Record."
- 37** Press SYSTEM, *HARMONIC MEAS*, *HARMONIC OFF*.

Port 2 Input Worst Case 2nd Harmonic

- 38** Press STOP, 1.5, G/n to set the stop frequency for measuring the 2nd harmonic.
- 39** Press MEAS, *Trans: E/E S21 FWD*, *INPUT PORTS*, *B*.
- 40** After one sweep, press DISPLAY, *DATA→MEMORY*, *DATA/MEM* to normalize the trace.
- 41** Press SYSTEM, *HARMONIC MEAS*, *HARMONIC SECOND*.
- 42** After one sweep, press SCALE REF, *AUTO SCALE* to get a better viewing of the trace.
- 43** Press MARKER FCTN, *MARKER MODE MENU*, *MKR SEARCH*, *SEARCH MAX*.
- 44** Write the marker 1 value (which appears on the analyzer display) on the "Performance Test Record." This is the worst case port 2 input (receiver channel B) 2nd harmonic.

Port 2 Input Worst Case 3rd Harmonic

- 45** Press STOP, 1, G/n to change the stop frequency for measuring the receiver 3rd harmonic.
- 46** Press SYSTEM, *HARMONIC MEAS*, *HARMONIC OFF*.
- 47** After one sweep, press DISPLAY, *DATA→MEMORY*, *DATA/MEM* to normalize the trace.

17. Test Port Output/Input Harmonics (Option 002 Analyzers without Option 006 Only)

- 48** Press SCALE REF, *AUTO SCALE*, *SCALE/DIV*, 1, x1 to get a better viewing of the trace.
- 49** Press SYSTEM, *HARMONIC MEAS*, *HARMONIC THIRD*.
- 50** After one sweep, press SCALE REF, *AUTO SCALE*.
- 51** Press MARKER FCTN, *MARKER MODE MENU*, *MKR SEARCH*, *SEARCH MAX*.
- 52** Write the marker 1 value on the "Performance Test Record."

18. Test Port Output/Input Harmonics (Option 002 Analyzers with Option 006 Only)

18. Test Port Output/Input Harmonics (Option 002 Analyzers with Option 006 Only)

Perform this test to determine the spectral purity of the HP 8702D input and output test ports.

**Required
Equipment**

Cable, APC-7, 24-inch HP P/N 8120-4779
Attenuator (2), 20 dB HP 8492A Option 020

Procedure

NOTE

The test port input 3rd harmonic specifications are *better* than the test port output 3rd harmonic specifications.

Test Port Output Worst Case 2nd Harmonic

- 1 Press PRESET, MENU, *POWER*, 10, x1 to set the test port power to +10 dBm.
- 2 Press START, 16, M/ μ , STOP, 3, G/h to set the frequency range.
- 3 Press AVG, *IF BW*, 10, x1 to set the IF bandwidth to 10 Hz.
- 4 Connect the equipment as shown in Figure 4-38.

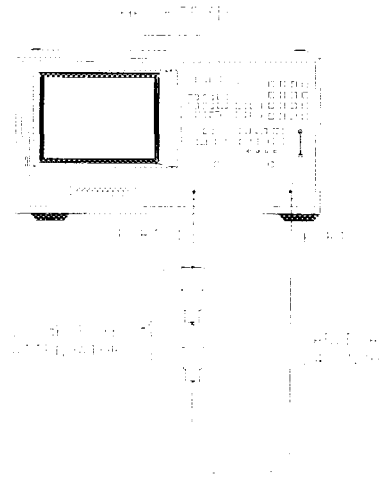
18. Test Port Output/Input Harmonics (Option 002 Analyzers with Option 006 Only)**Figure 4-38. Test Port Output Harmonics Test Setup**

- 5** Press MEAS, *Trans: E/E S12 REV, INPUT PORTS, A.*
- 6** After one sweep, press DISPLAY, *DATA→MEMORY, DATA/MEM* to normalize the trace.
- 7** Press SYSTEM, *HARMONIC MEAS, HARMONIC SECOND.*
- 8** After one sweep, press SCALE REF, *AUTO SCALE* to get a better viewing of the trace.
- 9** Press MARKER FCTN, *MARKER MODE MENU, MKR SEARCH, SEARCH MAX.*
- 10** Write the marker 1 value (which appears on the analyzer display) on the "Performance Test Record." This is the worst case test port output 2nd harmonic.

Test Port Output Worst Case 3rd Harmonic

- 11** Press STOP, 2, G/n to change the stop frequency to 1 GHz.
- 12** Press SYSTEM, *HARMONIC MEAS, HARMONIC OFF.*
- 13** After one sweep, press DISPLAY, *DATA→MEMORY, DATA/MEM* to normalize the trace.
- 14** Press SCALE REF, *AUTO SCALE, SCALE/DIV, 1, x1* to get a better viewing of the trace.

18. Test Port Output/Input Harmonics (Option 002 Analyzers with Option 006 Only)

- 15 Press SYSTEM, *HARMONIC MEAS, HARMONIC THIRD.*
- 16 After one sweep, press SCALE REF, *AUTO SCALE.*
- 17 Press MARKER FCTN, *MARKER MODE MENU, MKR SEARCH, SEARCH MAX.*
- 18 Write the marker 1 value on the "Performance Test Record."

Port 1 Input Worst Case 2nd Harmonic

- 19 Connect the equipment as shown in Figure 4-39.

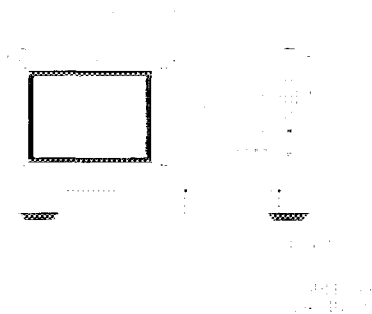
**Figure 4-39. Receiver Harmonics Test Setup**

- 20 Press PRESET, MENU, *POWER, 8, x1.*
- 21 Press AVG, *IF BW, 10, x1.*
- 22 Press START, *16, M/μ, STOP, 3, G/n* to set the frequency range.
- 23 Press MEAS, *Trans: E/E S12 REV, INPUT PORTS, A.*
- 24 After one sweep, press DISPLAY, *DATA→MEMORY, DATA/MEM* to normalize the trace.
- 25 Press SYSTEM, *HARMONIC MEAS, HARMONIC SECOND.*
- 26 After one sweep, press SCALE REF, *AUTO SCALE* to get a better viewing of the trace.
- 27 Press MARKER FCTN, *MARKER MODE MENU, MKR SEARCH, SEARCH: MAX.*

18. Test Port Output/Input Harmonics (Option 002 Analyzers with Option 006 Only)

- 28** Write the marker 1 value (which appears on the analyzer display) on the "Performance Test Record." This is the worst case port 1 input (receiver channel A) 2nd harmonic.

Port 1 Input Worst Case 3rd Harmonic

- 29** Press STOP, 2, G/n to change the stop frequency for measuring the receiver 3rd harmonic.
- 30** Press SYSTEM, *HARMONIC MEAS*, *HARMONIC OFF*.
- 31** After one sweep, press DISPLAY, *DATA→MEMORY*, *DATA/MEM* to normalize the trace.
- 32** Press SCALE REF, *AUTO SCALE*, *SCALE/DIV*, 1, x1 to get a better viewing of the trace.
- 33** Press SYSTEM, *HARMONIC MEAS*, *HARMONIC THIRD*.
- 34** After one sweep, press SCALE REF, *AUTO SCALE*.
- 35** Press MARKER FCTN, *MARKER MODE MENU*, *MKR SEARCH*, *SEARCH:MAX*.
- 36** Write the marker 1 value on the "Performance Test Record."
- 37** Press SYSTEM, *HARMONIC MEAS*, *HARMONIC OFF*.

Port 2 Input Worst Case 2nd Harmonic

- 38** Press STOP, 3, G/n to set the stop frequency for measuring the 2nd harmonic.
- 39** Press MEAS, *Trans: E/E S21 FWD*, *INPUT PORTS*, *B*.
- 40** After one sweep, press DISPLAY, *DATA→MEMORY*, *DATA/MEM* to normalize the trace.
- 41** Press SYSTEM, *HARMONIC MEAS*, *HARMONIC SECOND*.
- 42** After one sweep, press SCALE REF, *AUTO SCALE* to get a better viewing of the trace.
- 43** Press MARKER FCTN, *MARKER MODE MENU*, *MKR SEARCH*, *SEARCH MAX*.
- 44** Write the marker 1 value (which appears on the analyzer display) on the "Performance Test Record." This is the worst case port 2 input (receiver channel B) 2nd harmonic.

Port 2 Input Worst Case 3rd Harmonic

- 45** Press STOP, 2, G/n to change the stop frequency for measuring the receiver 3rd harmonic.

18. Test Port Output/Input Harmonics (Option 002 Analyzers with Option 006 Only)

- 46 Press SYSTEM, *HARMONIC MEAS*, *HARMONIC OFF*.
- 47 After one sweep, press DISPLAY, *DATA*→*MEMORY*, *DATA/MEM* to normalize the trace.
- 48 Press SCALE REF, *AUTO SCALE*, *SCALE/DIV*, 1, x1 to get a better viewing of the trace.
- 49 Press SYSTEM, *HARMONIC MEAS*, *HARMONIC THIRD*.
- 50 After one sweep, press SCALE REF, *AUTO SCALE*.
- 51 Press MARKER FCTN, *MARKER MODE MENU*, *MKR SEARCH*, *SEARCH: MAX*.
- 52 Write the marker 1 value on the "Performance Test Record."

Performance Test Records

The following tables are to record the performance test records for each of the tests.

Test 1. Test Port Output Frequency Range and Accuracy

Test Frequencies (MHz)	Min. (MHz)	Results Measured (MHz)	Max. (MHz)	Measurement Uncertainty (MHz)
0.03	0.029 999 7	_____	0.030 000 3	± 0.000 000 036
0.3	0.299 997	_____	0.300 003	± 0.000 000 360
5.0	4.999 950	_____	5.000 050	± 0.000 006
16.0	15.999 840	_____	16.000 160	± 0.000 019
31.0	30.999 690	_____	31.000 310	± 0.000 037
60.999 999	60.999 390	_____	61.000 610	± 0.000 073
121.0	120.998 790	_____	121.001 210	± 0.000 145
180.0	179.998 200	_____	180.001 800	± 0.000 216
310.0	309.995 900	_____	310.003 100	± 0.000 372
700.0	699.930 000	_____	700.007 000	± 0.000 840
1 300.0	1 299.987	_____	1 300.013	± 0.001 560
2 000.0	1 999.980	_____	2 000.020	± 0.002 400
3 000.0	2 999.970	_____	3 000.030	± 0.003 600
Option 006				
4.0	3.999 960	_____	4.000 040	± 0.004 800
5.0	4.999 950	_____	5.000 050	± 0.006 000
6.0	5.999 940	_____	6.000 060	± 0.007 200

Performance Tests
Performance Test Records

Test 2. External Source Mode Frequency Range

Test Frequencies (GHz)	Results
0.010	_____
0.020	_____
0.100	_____
1.000	_____
2.000	_____
3.000	_____
Option 006	
4.000	_____
5.000	_____
6.000	_____

Test 3. Test Port Output Power Accuracy

Test Frequency	Test Port Output Power (dBm)	Specification (dB)	Measured Value (dB)	Measurement Uncertainty (dB)
300 kHz	0	± 1	_____	± 0.15
20 MHz	0	± 1	_____	± 0.10
50 MHz	0	± 1	_____	± 0.10
100 MHz	0	± 1	_____	± 0.10
200 MHz	0	± 1	_____	± 0.10
500 MHz	0	± 1	_____	± 0.10
1 GHz	0	± 1	_____	± 0.10
2 GHz	0	± 1	_____	± 0.10
3 GHz	0	± 1	_____	± 0.15
Option 006				
4 GHz	0	± 1	_____	± 0.18
5 GHz	0	± 1	_____	± 0.18
6 GHz	0	± 1	_____	± 0.18

Performance Tests
Performance Test Records

Test 4. Test Port Output Power Range and Linearity (1 of 2)

Test Settings	Results Measured (dB)	Power Level Linearity (dB)	Specification (dB)	Measurement Uncertainty (dB)
CW Frequency = 300 kHz				
-15	_____	_____	± 0.2	± 0.15
-13	_____	_____	± 0.2	± 0.15
-11	_____	_____	± 0.2	± 0.15
-9	_____	_____	± 0.2	± 0.15
-7	_____	_____	± 0.2	± 0.15
-5	_____	_____	± 0.2	± 0.15
-3	_____	_____	± 0.2	± 0.15
-1	_____	_____	± 0.2	± 0.15
+1	_____	_____	± 0.2	± 0.15
+3	_____	_____	± 0.2	± 0.15
+5	_____	_____	± 0.5	± 0.15
+7	_____	_____	± 0.5	± 0.15
+9	_____	_____	± 0.5	± 0.15
+10	_____	_____	± 0.5	± 0.15
CW Frequency = 3 GHz				
-15	_____	_____	± 0.2	± 0.15
-13	_____	_____	± 0.2	± 0.15
-11	_____	_____	± 0.2	± 0.15
-9	_____	_____	± 0.2	± 0.15
-7	_____	_____	± 0.2	± 0.15
-5	_____	_____	± 0.2	± 0.15
-3	_____	_____	± 0.2	± 0.15
-1	_____	_____	± 0.2	± 0.15
+1	_____	_____	± 0.2	± 0.15

Test 4. Test Port Output Power Range and Linearity (2 of 2)

Test Settings	Results Measured (dB)	Power Level Linearity (dB)	Specification (dB)	Measurement Uncertainty (dB)
+3	_____	_____	± 0.2	± 0.15
+5	_____	_____	± 0.5	± 0.15
+7	_____	_____	± 0.5	± 0.15
+9	_____	_____	± 0.5	± 0.15
+10	_____	_____	± 0.5	± 0.15
Option 006				
CW Frequency = 6 GHz				
-15	_____	_____	± 0.2	± 0.15
-13	_____	_____	± 0.2	± 0.15
-11	_____	_____	± 0.2	± 0.15
-9	_____	_____	± 0.2	± 0.15
-7	_____	_____	± 0.2	± 0.15
-5	_____	_____	± 0.2	± 0.15
-3	_____	_____	± 0.2	± 0.15
-1	_____	_____	± 0.2	± 0.15
+1	_____	_____	± 0.2	± 0.15
+3	_____	_____	± 0.2	± 0.15
+5	_____	_____	± 0.5	± 0.15
+7	_____	_____	± 0.5	± 0.15
+9	_____	_____	± 0.5	± 0.15
+10	_____	_____	± 0.5	± 0.15

Performance Tests
Performance Test Records

Test 5. Minimum R Channel Level

CW Frequency	Specification (dB)	Test Port Power	Measurement Uncertainty (dB)
300 kHz	< -35	_____	± 1.0
3.29 MHz	< -35	_____	± 1.0
3.31 MHz	< -35	_____	± 1.0
15.90 MHz	< -35	_____	± 1.0
16.10 MHz	< -35	_____	± 1.0
30.90 MHz	< -35	_____	± 1.0
31.10 MHz	< -35	_____	± 1.0
1.6069 GHz	< -35	_____	± 1.0
1.6071 GHz	< -35	_____	± 1.0
3.00 GHz	< -35	_____	± 1.0
Option 006			
4.000 GHz	< -30	_____	± 3.0
5.000 GHz	< -30	_____	± 3.0
6.000 GHz	< -30	_____	± 3.0

Test 6. Test Port Input Noise Floor Level

Frequency Range	Test Port	IF Bandwidth	Specification (dBm)	Calculated Value	Measurement Uncertainty
50 kHz – 3 GHz	Port 1	3 kHz	- 82	_____	N/A
50 kHz – 3 GHz	Port 1	10 Hz	- 102	_____	N/A
50 kHz – 3 GHz	Port 2	10 Hz	- 102	_____	N/A
50 kHz – 3 GHz	Port 2	3 kHz	- 82	_____	N/A
Option 006					
3 GHz – 6 GHz	Port 2	3 kHz	- 77	_____	N/A
3 GHz – 6 GHz	Port 2	10 Hz	- 97	_____	N/A
3 GHz – 6 GHz	Port 1	10 Hz	- 97	_____	N/A
3 GHz – 6 GHz	Port 1	3 kHz	- 77	_____	N/A

Test 7. Test Port Input Frequency Response

Frequency Range	Test Port	Specification (dB)	Measured Value (dB)	Measurement Uncertainty (dB)
300 kHz – 3 GHz	Port 2	± 1	_____	0.15
300 kHz – 3 GHz	Port 1	± 1	_____	0.15
Option 006				
3 GHz – 6 GHz	Port 1	± 2	_____	0.18
3 GHz – 6 GHz	Port 2	± 2	_____	0.18

Performance Tests
Performance Test Records

Test 8. Test Port Crosstalk

Test Settings	Specification (dB)	Measured Value (dB)	Measurement Uncertainty
Crosstalk to Test Port 2 300 kHz – 3 GHz	< -100	_____	N/A
Crosstalk to Test Port 2 300 kHz – 3 GHz	< -100	_____	N/A
Option 006			
Crosstalk to Test Port 1 3 GHz – 6 GHz	< -90	_____	N/A
Crosstalk to Test Port 2 3 GHz – 6 GHz	< -90	_____	N/A

Test 9. Calibration Coefficients (1 of 2)

Test Description	Frequency Range	Specification (dB)	Measured Value (dB)	Measurement Uncertainty (dB)
Forward Direction				
Directivity	300 kHz – 1.3 GHz	≥ 35	_____	± 0.9
Directivity	1.3 GHz – 3 GHz	≥ 30	_____	± 0.8
Directivity (Option 006)	3 GHz – 6 GHz	≥ 25	_____	± 0.8
Forward Direction				
Source Match	300 kHz – 1.3 GHz	≥ 16	_____	± 0.2
Source Match	1.3 GHz – 3 GHz	≥ 16	_____	± 0.2
Source Match (Option 006)	3 GHz – 6 GHz	≥ 14	_____	± 0.3
Forward Direction				
Trans. Tracking	300 kHz – 1.3 GHz	± 1.5	_____	± 0.006
Trans. Tracking	1.3 GHz – 3 GHz	± 1.5	_____	± 0.009
Trans. Tracking (Option 006)	3 GHz – 6 GHz	± 2.5	_____	± 0.021
Forward Direction				
Refl. Tracking	300 kHz – 1.3 GHz	± 1.5	_____	± 0.001
Refl. Tracking	1.3 GHz – 3 GHz	± 1.5	_____	± 0.005
Refl. Tracking (Option 006)	3 GHz – 6 GHz	± 2.5	_____	± 0.020
Reverse Direction				
Load Match	300 kHz – 1.3 GHz	≥ 18	_____	± 0.1
Load Match	1.3 GHz – 3 GHz	≥ 16	_____	± 0.2
Load Match (Option 006)	3 GHz – 6 GHz	≥ 14	_____	± 0.2
Reverse Direction				

Performance Tests
Performance Test Records

Test 9. Calibration Coefficients (2 of 2)

Test Description	Frequency Range	Specification (dB)	Measured Value (dB)	Measurement Uncertainty (dB)
Trans. Tracking	300 kHz – 1.3 GHz	± 1.5	_____	± 0.006
Trans. Tracking	1.3 GHz – 3 GHz	± 1.5	_____	± 0.009
Trans. Tracking (Option 006)	3 GHz – 6 GHz	± 2.5	_____	± 0.021
Forward Direction				
Load Match	300 kHz – 1.3 GHz	≥ 18	_____	± 0.1
Load Match	1.3 GHz – 3 GHz	≥ 16	_____	± 0.2
Load Match (Option 006)	3 GHz – 6 GHz	≥ 14	_____	± 0.2
Reverse Direction				
Directivity	300 kHz – 1.3 GHz	≥ 35	_____	± 0.9
Directivity	1.3 GHz – 3 GHz	≥ 30	_____	± 0.8
Directivity (Option 006)	3 GHz – 6 GHz	≥ 25	_____	± 0.8
Reverse Direction				
Source Match	300 kHz – 1.3 GHz	≥ 16	_____	± 0.2
Source Match	1.3 GHz – 3 GHz	≥ 16	_____	± 0.2
Source Match (Option 006)	3 GHz – 6 GHz	≥ 14	_____	± 0.3
Reverse Direction				
Refl. Tracking	300 kHz – 1.3 GHz	± 1.5	_____	± 0.001
Refl. Tracking	1.3 GHz – 3 GHz	± 1.5	_____	± 0.005
Refl. Tracking (Option 006)	3 GHz – 6 GHz	± 2.5	_____	± 0.020

Test 10. System Trace Noise (Only for Analyzers without Option 006)

CW Frequency (GHz)	Ratio	Measured Value	Specification	Measurement Uncertainty
3	A/R	_____	< 0.006 dB rms	N/A
3	A/R	_____	< 0.038° rms	N/A
3	B/R	_____	< 0.006 dB rms	N/A
3	B/R	_____	< 0.038° rms	N/A

Test 11. System Trace Noise (Only for Analyzers with Option 006)

CW Frequency (GHz)	Ratio	Measured Value	Specification	Measurement Uncertainty
3	A/R (Magnitude)	_____	≤ 0.006 dB rms	N/A
6	A/R (Magnitude)	_____	≤ 0.010 dB rms	N/A
6	A/R (Phase)	_____	≤ 0.070° rms	N/A
3	A/R (Phase)	_____	≤ 0.038° rms	N/A
3	B/R (Magnitude)	_____	≤ 0.006 dB rms	N/A
6	B/R (Magnitude)	_____	≤ 0.010 dB rms	N/A
6	B/R (Phase)	_____	≤ 0.070° rms	N/A
3	B/R (Phase)	_____	≤ 0.038° rms	N/A

Performance Tests
Performance Test Records

Test 12. Test Port Input Impedance

Test Description	Test Port	Return Loss (dB)	Specification (dB)	Measurement Uncertainty (dB)
300 kHz – 1.3 GHz	Port 2	_____	≥ 18	± 1.5
1.3 GHz – 3 GHz	Port 2	_____	≥ 16	± 1.5
3 GHz – 6 GHz (Option 006)	Port 2	_____	≥ 14	± 1.0
300 kHz – 1.3 GHz	Port 1	_____	≥ 18	± 1.5
1.3 GHz – 3 GHz	Port 1	_____	≥ 16	± 1.5
3 GHz – 6 GHz (Option 006)	Port 1	_____	≥ 14	± 1.0

Test 13. Test Port Receiver Magnitude Dynamic Accuracy

Test Port Input Power	8496A Setting (dB)	Test Port (dB)	8902A (dB)	Calculated Value (dB)	Spec. (dB)	Mea. Uncer. (dB)
Test Port 2						
- 10	0	_____	_____	_____	≤ 0.059	± 0.01
- 20	10	_____	_____	_____	≤ 0.050	± 0.02
- 30	20	_____	_____	_____	≤ 0.050	± 0.02
- 40	30	_____	_____	_____	≤ 0.053	± 0.04
- 50	40	_____	_____	_____	≤ 0.058	± 0.06
- 60	50	_____	_____	_____	≤ 0.095	± 0.08
- 70	60	_____	_____	_____	≤ 0.250	± 0.14
- 80	70	_____	_____	_____	≤ 0.750	± 0.16
- 90	80	_____	_____	_____	≤ 2.200	± 0.18
- 100	90	_____	_____	_____	≤ 5.200	± 0.20
Test Port 1						
- 10	0	_____	_____	_____	≤ 0.059	± 0.01
- 20	10	_____	_____	_____	≤ 0.050	± 0.02
- 30	20	_____	_____	_____	≤ 0.050	± 0.02
- 40	30	_____	_____	_____	≤ 0.053	± 0.04
- 50	40	_____	_____	_____	≤ 0.058	± 0.06
- 60	50	_____	_____	_____	≤ 0.095	± 0.08
- 70	60	_____	_____	_____	≤ 0.250	± 0.14
- 80	70	_____	_____	_____	≤ 0.750	± 0.16
- 90	80	_____	_____	_____	≤ 2.200	± 0.18
- 100	90	_____	_____	_____	≤ 5.200	± 0.20

Performance Tests
Performance Test Records

Test 14. Test Port Receiver Phase Dynamic Accuracy

Test Port Input Power	Calculated Value (dB)	A	B	Results Value (degrees)	Spec. (degrees)	Mea. Uncer.
Test Port 2						
- 10	_____	_____	_____	_____	≤ 0.42	N/A
- 20	_____	_____	_____	_____	≤ 0.35	N/A
- 30	_____	_____	_____	_____	≤ 0.35	N/A
- 40	_____	_____	_____	_____	≤ 0.36	N/A
- 50	_____	_____	_____	_____	≤ 0.39	N/A
- 60	_____	_____	_____	_____	≤ 0.64	N/A
- 70	_____	_____	_____	_____	≤ 1.75	N/A
- 80	_____	_____	_____	_____	≤ 5.00	N/A
- 90	_____	_____	_____	_____	≤ 17.50	N/A
- 100	_____	_____	_____	_____	≤ 53.00	N/A
Test Port 1						
- 10	_____	_____	_____	_____	≤ 0.42	N/A
- 20	_____	_____	_____	_____	≤ 0.35	N/A
- 30	_____	_____	_____	_____	≤ 0.35	N/A
- 40	_____	_____	_____	_____	≤ 0.36	N/A
- 50	_____	_____	_____	_____	≤ 0.39	N/A
- 60	_____	_____	_____	_____	≤ 0.64	N/A
- 70	_____	_____	_____	_____	≤ 1.75	N/A
- 80	_____	_____	_____	_____	≤ 5.00	N/A
- 90	_____	_____	_____	_____	≤ 17.50	N/A
- 100	_____	_____	_____	_____	≤ 53.00	N/A

Test 15. Test Port Receiver Magnitude Compression

CW Frequency	Test Port	Measured Value (dB)	Specification (dB)	Measurement Uncertainty
50 MHz	Port 2	_____	≤ 0.45	N/A
1 GHz	Port 2	_____	≤ 0.45	N/A
2 GHz	Port 2	_____	≤ 0.45	N/A
3 GHz	Port 2	_____	≤ 0.45	N/A
4 GHz (Option 006)	Port 2	_____	≤ 0.80	N/A
5 GHz (Option 006)	Port 2	_____	≤ 0.80	N/A
6 GHz (Option 006)	Port 2	_____	≤ 0.80	N/A
50 MHz	Port 1	_____	≤ 0.45	N/A
1 GHz	Port 1	_____	≤ 0.45	N/A
2 GHz	Port 1	_____	≤ 0.45	N/A
3 GHz	Port 1	_____	≤ 0.45	N/A
4 GHz (Option 006)	Port 1	_____	≤ 0.80	N/A
5 GHz (Option 006)	Port 1	_____	≤ 0.80	N/A
6 GHz (Option 006)	Port 1	_____	≤ 0.80	N/A

Performance Tests
Performance Test Records

Test 16. Test Port Receiver Phase Compression

CW Frequency	Test Port	Measured Value (degrees)	Specification (degrees)	Measurement Uncertainty
50 MHz	Port 2	_____	$\leq 6^\circ$	N/A
1 GHz	Port 2	_____	$\leq 6^\circ$	N/A
2 GHz	Port 2	_____	$\leq 6^\circ$	N/A
3 GHz	Port 2	_____	$\leq 6^\circ$	N/A
4 GHz (Option 006)	Port 2	_____	$\leq 7.5^\circ$	N/A
5 GHz (Option 006)	Port 2	_____	$\leq 7.5^\circ$	N/A
6 GHz (Option 006)	Port 2	_____	$\leq 7.5^\circ$	N/A
50 MHz	Port 1	_____	$\leq 6^\circ$	N/A
1 GHz	Port 1	_____	$\leq 6^\circ$	N/A
2 GHz	Port 1	_____	$\leq 6^\circ$	N/A
3 GHz	Port 1	_____	$\leq 6^\circ$	N/A
4 GHz (Option 006)	Port 1	_____	$\leq 7.5^\circ$	N/A
5 GHz (Option 006)	Port 1	_____	$\leq 7.5^\circ$	N/A
6 GHz (Option 006)	Port 1	_____	$\leq 7.5^\circ$	N/A

Test 17. Test Port Output/Input Harmonics (Option 002 Analyzers without Option 006 Only)

Test Description	Specification (dBc)	Measurement Value (dBc)	Measurement Uncertainty (dB)
Test Port Output Harmonics			
2nd	≤ 25	_____	± 1.0
3rd	≤ 25	_____	± 1.0
Port 1 Input Harmonics			
2nd	≤ 15	_____	± 1.0
3rd	≤ 30	_____	± 1.0
Port 2 Input Harmonics			
2nd	≤ 15	_____	± 1.0
3rd	≤ 30	_____	± 1.0

Test 18. Test Port Output/Input Harmonics (Option 002 Analyzers with Option 006 Only)

Test Description	Specification (dBc)	Measurement Value (dBc)	Measurement Uncertainty (dB)
Test Port Output Harmonics			
2nd	≤ 25	_____	± 3.0
3rd	≤ 25	_____	± 3.0
Port 1 Input Harmonics			
2nd	≤ 15	_____	± 3.0
3rd	≤ 30	_____	± 3.0
Port 2 Input Harmonics			
2nd	≤ 15	_____	± 3.0
3rd	≤ 30	_____	± 3.0

Performance Tests
Performance Test Records

—

—

—

Automated Verification – Option 011

Automated Performance Verification for Option 011

The automated performance verification procedures in this chapter provide a high level of confidence that the HP 8702D Option 011 is working properly. Performance verification procedures are provided for the HP 8702D Option 011 using the:

- 1 HP 85046A or 85047A S-Parameter Test Set
- 2 HP 85044A Transmission/Reflection Test Set

Although these procedures are automated, they *do not* require a computer. However, you'll need to locate the *Verification Data Disk*.

Allow the HP 8702D Option 011 to warm up for one hour before starting this procedure.

Hewlett-Packard recommends that you verify your analyzer measurement system every six months. Hewlett-Packard also suggests that you get your verification kit recertified annually. Refer to the *HP 85029B Option 001 7 mm Verification Kit Operating and Service Manual* for more information.

HP 8753D is shown in the figures

The procedures in this chapter are designed to work with HP 8702D and HP 8753D instruments. Because of this, many of the figures label the instrument being tested as an HP 8753D. Simply substitute your HP 8702D for the HP 8753D.

How to select the system verification procedure

Check to see how the verification kit floppy disk is labeled:

- If the disk is labeled Verification Data Disk, proceed with the HP 8702D Option 011 Automated Mode System Verification in this chapter.
- If the disk is labeled Verification Data Disc, proceed with the HP 8702D Manual Mode System Verification procedure in Chapter 3, “Manual Verification”.

NOTE

If your verification disk is older than your HP 8702D Option 011, you may send your HP 85029B Option 001 7 mm verification kit to the nearest service center for recertification, which includes a data disk that you can use with the HP 8702D Option 011.

What you'll find in this chapter

- HP 8702D Option 011 and HP 85046A/47A System Verification 5-4
 - Step 1. Initialization 5-5
 - Step 2. Measurement Calibration 5-7
 - Step 3. Device Verification 5-10
 - In Case of Difficulty 5-14
- HP 8702D Option 011 and HP 85044A System Verification 5-15
 - Step 1. Initialization 5-16
 - Step 2. Measurement Calibration 5-17
 - Step 3. Device Verification 5-19
 - In Case of Difficulty 5-23

HP 8702D Option 011 and HP 85046A/47A System Verification

In order to run this procedure, the following equipment is required:

S-Parameter test set (for analyzers <i>without</i> Option 006)	HP 85046A
S-Parameter test set (for analyzers <i>with</i> Option 006)	HP 85047A
Calibration Kit, 7 mm	HP 85031B
Verification Kit, 7 mm	HP 85029B
RF Cable Set, 7 mm, 50 Ω	HP 11857D
Printer	HP ThinkJet/DeskJet/LaserJet

NOTE

Do *not* proceed any further if your system has an HP 85044A Transmission/Reflection test set. Instead, go to "HP 8702D Option 011 and HP 85044A System Verification" on page 5-15.

Step 1. Initialization

- 1 Connect the equipment as shown in Figure 5-1. Let the HP 8702D Option 011 warm up for one hour.

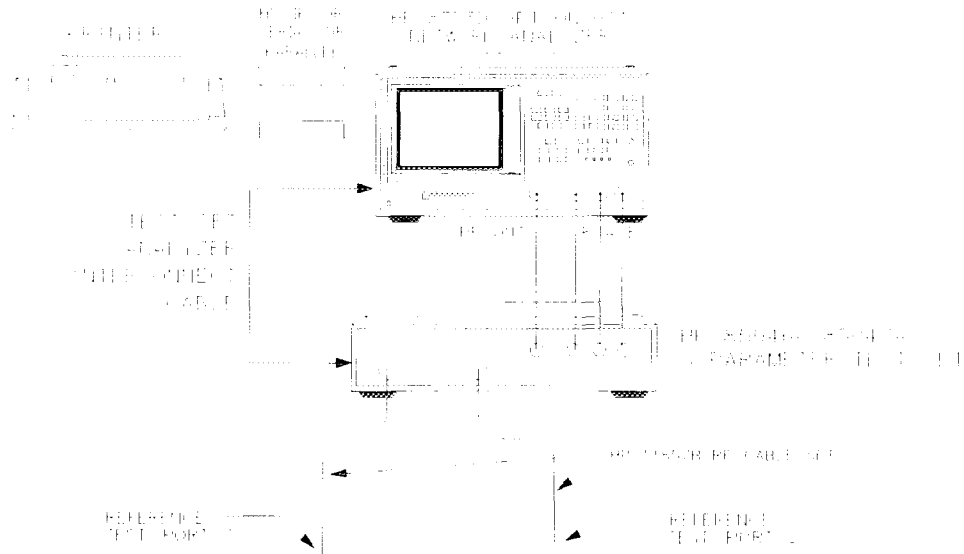

Figure 5-1. System Verification Test Setup

- 2 While the equipment is warming up, review the connector care information in the *HP 8702D User's Guide*.
- 3 Insert the verification kit disk into the analyzer's disk drive.
- 4 Press PRESET, SAVE/RECALL, SELECT DISK, INTERNAL DISK.
- 5 If you want a printout of the verification data for all the devices, press SYSTEM, SERVICE MENU, TEST OPTIONS, RECORD ON.

If you switch the record function on, you *cannot* switch it off during the verification procedure.

- 6 Position the paper in the printer so that printing starts at the top of the page.
- 7 Press SYSTEM, SERVICE MENU, TESTS, SYS VER TESTS, EXECUTE TEST.

Step 1. Initialization

- 8 When the analyzer displays, `Sys Ver Init Done`, the initialization procedure is complete.

Do *not* press PRESET or recall another instrument state. You must use the instrument state that you loaded during the initialization procedure.

Step 2. Measurement Calibration

- 7 Press *FORWARD:SHORT*.
- 8 When the analyzer displays the message *CONNECT STD THEN PRESS KEY TO MEASURE*, connect the 50 ohm termination (supplied in the calibration kit) to reference test port 1, as shown in Figure 5-2.
- 9 Press *FORWARD:LOAD*.
- 10 When the analyzer finishes measuring the standard, connect the "open" end of the open/short combination to reference test port 2, as shown in Figure 5-2.
- 11 Press *REVERSE:OPEN*.
- 12 When the analyzer displays the message *CONNECT STD THEN PRESS KEY TO MEASURE*, connect the "short" end of the open/short combination to reference port 2 as shown in Figure 5-2.
- 13 Press *REVERSE:SHORT*.
- 14 When the analyzer finishes measuring the standard, connect the 50 ohm termination to reference port 2, as shown in Figure 5-2.
- 15 Press *REVERSE:LOAD*.
- 16 When the analyzer finishes measuring the standard, press *STANDARDS DONE*.
- 17 Connect the test port cables as shown Figure 5-3.



Figure 5-3. Transmission Calibration Setup

Step 2. Measurement Calibration

- 18** Press *TRANSMISSION, FWD TRANS THRU*.
- 19** When the analyzer finishes the measurement, press *FWD MATCH THRU*.
- 20** When the analyzer finishes the measurement, press *REV TRANS THRU*.
- 21** When the analyzer finishes the measurement, press *REV MATCH THRU*.
- 22** When the analyzer displays, *PRESS 'DONE' IF FINISHED WITH STD(s)*, press *STANDARDS DONE, DONE 2-PORT CAL*.
- 23** Press *SAVE/RECALL, SELECT DISK, INTERNAL MEMORY, RETURN, SAVE STATE* to save the calibration into the analyzer's internal memory.
- 24** When the analyzer finishes storing the measurement calibration, press *SELECT DISK, INTERNAL DISK*.

Step 3. Device Verification**Step 3. Device Verification**

- 1 Press **SYSTEM**, **SERVICE MENU**, **TESTS**, **28**, **x1**, **EXECUTE TEST**.
- 2 At the prompt, connect the 20 dB attenuator (supplied in the verification kit) as shown in Figure 5-4.

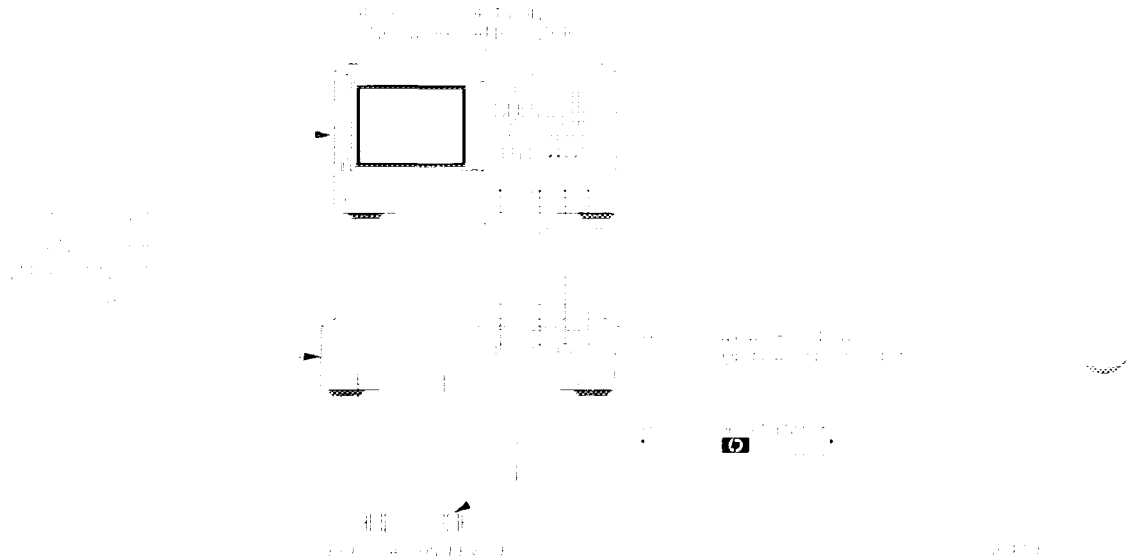

Figure 5-4. Connections for the 20 dB Verification Device

- 3 Press **CONTINUE** to run the test:
 - If you switched the record function *off*, you have to press **CONTINUE** after each S-parameter measurement.
 - If you switched the record function *on*, the test displays and prints the pass/fail information for the S-parameter measurements that are valid for system verification.

4 When the analyzer finishes all the measurements, connect the 50 dB attenuator (supplied in the verification kit), as shown in Figure 5-5.

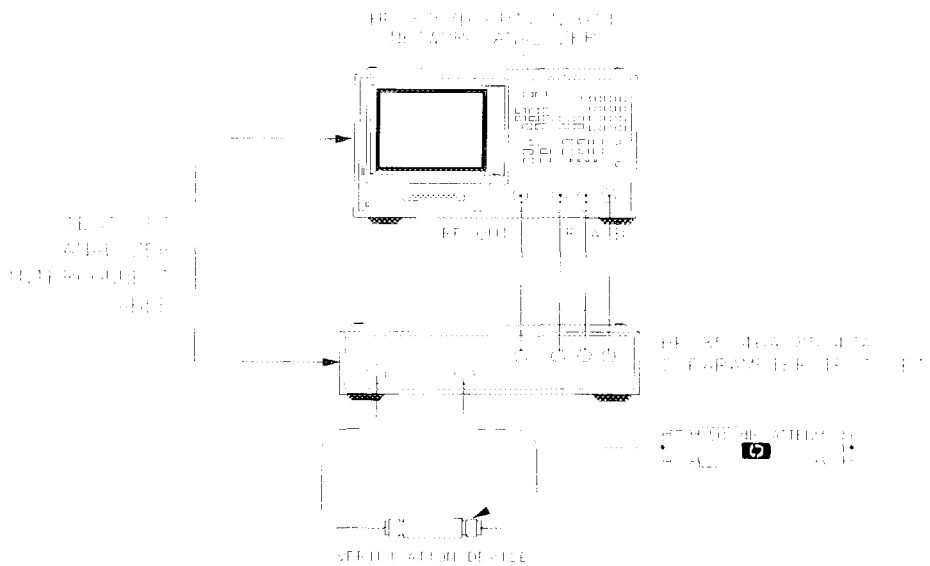

Figure 5-5. Connections for the 50 dB Verification Device

5 Press *RETURN*, *TESTS*, 29, x1, *EXECUTE TEST*, *CONTINUE*.

Step 3. Device Verification

- 6 When all measurements are complete, replace the attenuator with the verification mismatch, as shown in Figure 5-6.

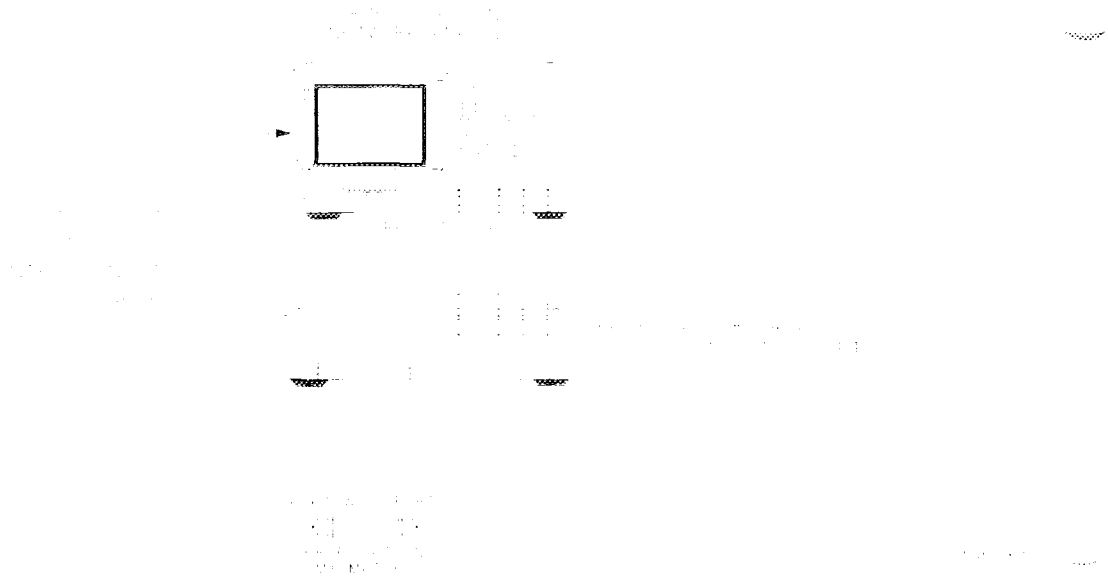

Figure 5-6. Mismatch Device Verification Setup

- 7 Press *RETURN*, *TESTS*, 30, *x1*, *EXECUTE TEST*, *CONTINUE*.

- 8 When the analyzer finishes all the measurements, reconnect the mismatch verification device, as shown in Figure 5-7.

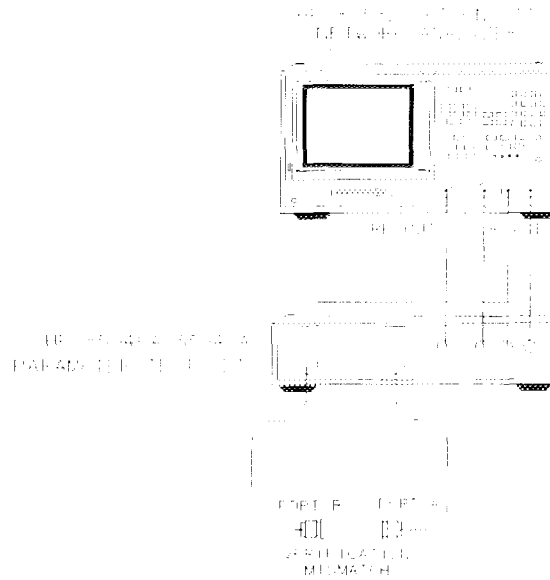

Figure 5-7. Mismatch Device Verification Setup

- 9 Press *RETURN*, *TESTS*, 31, x1, *EXECUTE TEST*, *CONTINUE*.
- 10 You have completed the system verification procedure when the analyzer displays, *TEST 31 Ver Dev 4 PASS*.

In Case of Difficulty

In Case of Difficulty

- 1** Inspect all connections. Do *not* disconnect the cables from the analyzer test ports. Doing so will invalidate the calibration that you have done earlier.
- 2** Press PRESET, SAVE/RECALL.
 - a** Using the front panel knob, highlight the title of the full 2-port measurement calibration that you have done earlier.
 - b** Press *RECALL STATE*.
 - c** Repeat “Step 3. Device Verification” on page 5-10.
- 3** If the analyzer still fails the test, check the measurement calibration as follows:
 - a** Press PRESET.
 - b** Recall the calibration by pressing SAVE/RECALL. *SELECT DISK, INTERNAL MEMORY, RETURN*.
 - c** Use the front panel knob to highlight the calibration you want to recall and press *RECALL STATE*.
 - d** Connect the short to reference test port 1.
 - e** Press MEAS, *Ref: E S11 FWD*.
 - f** Press MENU, *TRIGGER MENU, CONTINUOUS*.
 - g** Press SCALE REF, *AUTO SCALE, SCALE/DIV, .01, x1*.
 - h** Check that the trace response is 0.00 ± 0.05 dB.
 - i** Disconnect the short and connect it reference test port 2.
 - j** Press MEAS, *Ref: E S22 REV*.
 - k** Check that the trace response is 0.00 ± 0.05 dB.
 - l** If any of the trace responses are out of the specified limits, repeat the “Measurement Calibration” and “Device Verification” procedures.
- 4** Refer to the *HP 8753D Option 011 Service Guide* for more troubleshooting information.

HP 8702D Option 011 and HP 85044A System Verification

In order to run this procedure, the following equipment is required:

Transmission/reflection test set	HP 85044A
Calibration Kit, 7 mm	HP 85031B
Verification Kit, 7 mm	HP 85029B
RF Cable Set, Type-N 50 Ω	HP 11851B
Adapter, APC-7 to Type-N (f)	HP 11524A
Printer	HP ThinkJet/DeskJet/LaserJet

NOTE

Do *not* proceed any further if your system has an HP 85046A or 85047A S-Parameter test set. Instead, go to "HP 8702D Option 011 and HP 85046A/47A System Verification" on page 5-4.

Step 1. Initialization

Step 1. Initialization

- 1 Connect the equipment as shown in Figure 5-8. Let the HP 8702D Option 011 warm up for one hour.

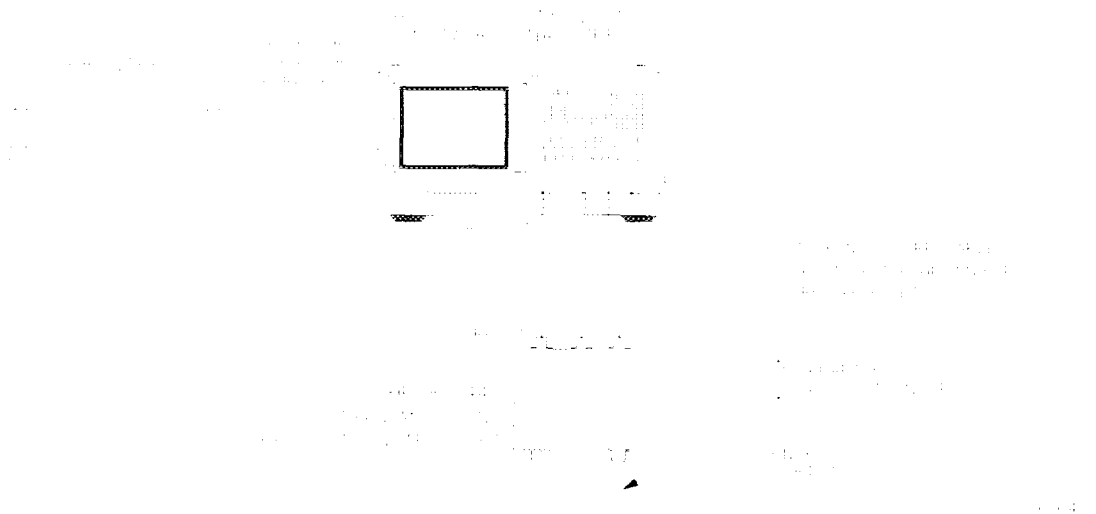

Figure 5-8. System Verification Test Setup

- 2 While the equipment is warming up, review the connector care information in the *HP 8702D User's Guide*.
- 3 Insert the verification kit disk into the analyzer's disk drive.
- 4 Press PRESET, SAVE/RECALL, *SELECT DISK*, *INTERNAL DISK*.
- 5 If you want a printout of the verification data for all the devices, press SYSTEM, *SERVICE MENU*, *TEST OPTIONS*, *RECORD ON*.
If you switch the record function on, you cannot switch it off during the verification procedure.
- 6 Position the paper in the printer so that printing starts at the top of the page.
- 7 Press SYSTEM, *SERVICE MENU*, *TESTS*, *SYS VER TESTS*, *EXECUTE TEST*.
- 8 The analyzer displays, Sys Ver Init DONE, when the initialization procedure is complete.

Do *not* press PRESET or recall another instrument state. You must use the instrument state that you loaded during the initialization procedure.

Step 2. Measurement Calibration

- 1 Press *CAL*, *CAL KIT & STDS*, *SELECT CAL KIT*, *CAL KIT:7mm*, *RETURN*, *RETURN*, *CALIBRATE MENU*, *ONE-PATH 2-PORT*.
- 2 Press *ISOLATION*, *OMIT ISOLATION*, *ISOLATION DONE*.
- 3 Press *REFLECTION*.
- 4 Connect the “open” end of the open/short combination (supplied in the calibration kit) to reference test port 1, as shown in Figure 5-9.

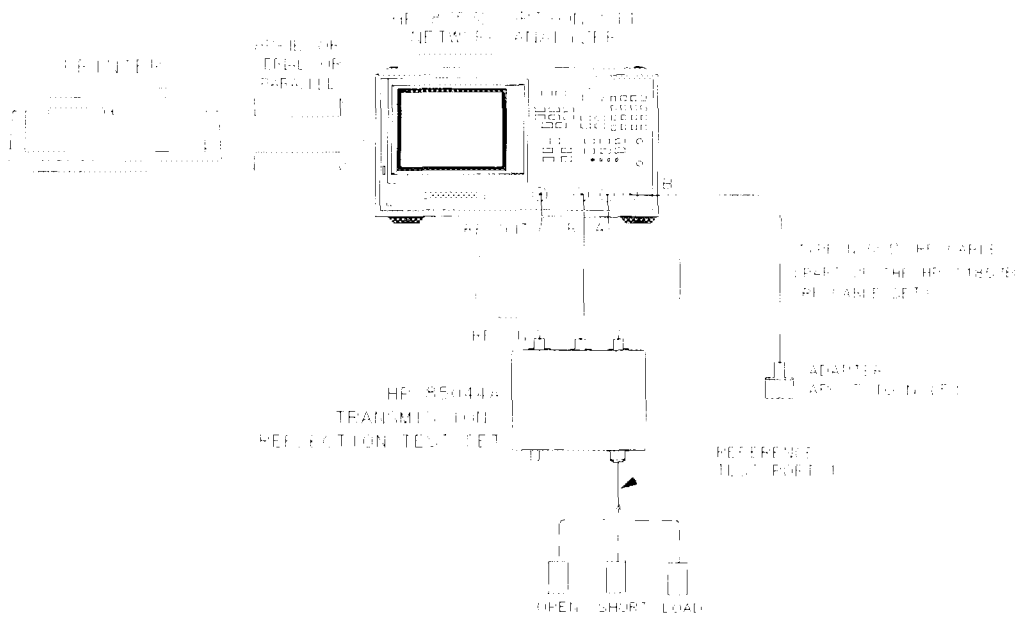

Figure 5-9. Connections for Measurement Calibration Standards

- 5 Press *FORWARD:OPEN*. The analyzer displays the message *WAIT--MEASURING CAL STD*.
- 6 When the analyzer finishes measuring the standard, connect the “short” end of the open/short combination to reference test port 1, as shown in Figure 5-9.
- 7 Press *FORWARD:SHORT*.

Step 2. Measurement Calibration

- 8** When the analyzer displays the message *CONNECT STD THEN PRESS KEY TO MEASURE*, connect the 50 ohm termination (supplied in the calibration kit) to reference test port 1, as shown in Figure 5-9.
- 9** Press *FORWARD:LOAD*.
- 10** When the analyzer finishes measuring the standard, press *STANDARDS DONE*.
- 11** Connect the test port cables as shown Figure 5-10.

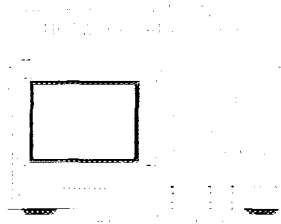

Figure 5-10. Transmission Calibration Setup

- 12** Press *TRANSMISSION, FWD TRANS THRU*.
- 13** When the analyzer finishes the measurement, press *FWD MATCH THRU*.
- 14** When the analyzer displays, *PRESS 'DONE' IF FINISHED WITH STD(s)*, press *STANDARDS DONE, DONE 2-PORT CAL*.
- 15** Press *SAVE/RECALL, SELECT DISK, INTERNAL MEMORY, RETURN, SAVE STATE* to save the calibration into the analyzer's internal memory.
- 16** When the analyzer finishes storing the measurement calibration, press *SELECT DISK, INTERNAL DISK*.

Step 3. Device Verification

- 1 Press **SYSTEM**, **SERVICE MENU**, **TESTS**, **28**, **x1**, **EXECUTE TEST**.
- 2 At the prompt, connect the 20 dB attenuator (supplied in the verification kit) as shown in Figure 5-11.

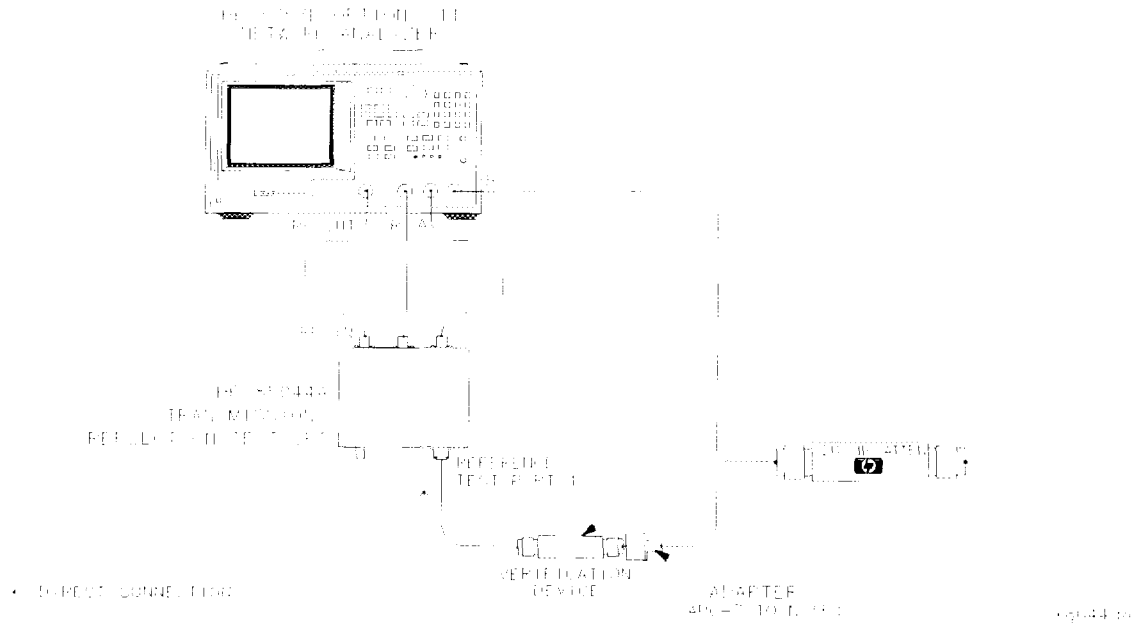

Figure 5-11. Connections for the 20 dB Attenuator

- 3 Press **CONTINUE** to run the test:
 - If you switched the record function *off*, you have to press **CONTINUE** after each S-parameter measurement.
 - If you switched the record function *on*, the test displays and prints the pass/fail information for the S-parameter measurements that are valid for system verification.

Step 3. Device Verification

- 4 When the analyzer finishes all the measurements, connect the 50 dB attenuator (supplied in the verification kit), as shown in Figure 5-12.

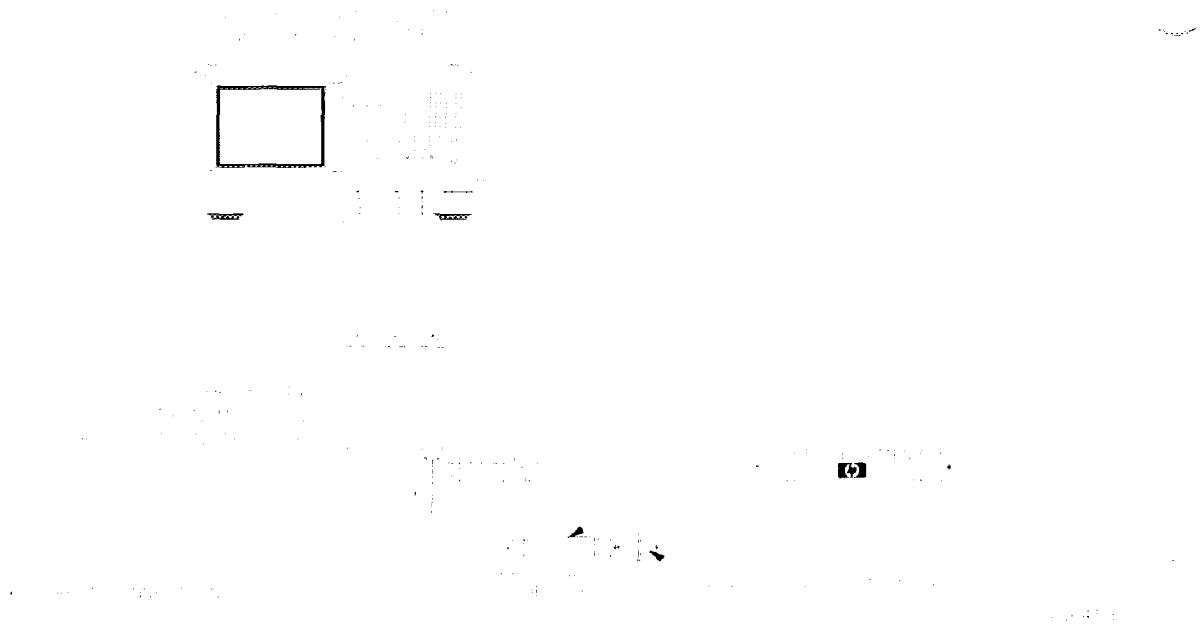

Figure 5-12. Connections for the 50 dB Attenuator

- 5 Press *RETURN*, *TESTS*, 29, x1, *EXECUTE TEST*, *CONTINUE*.

Step 3. Device Verification

- 8 When the analyzer finishes all the measurements, reconnect the mismatch verification device, as shown in Figure 5-14.

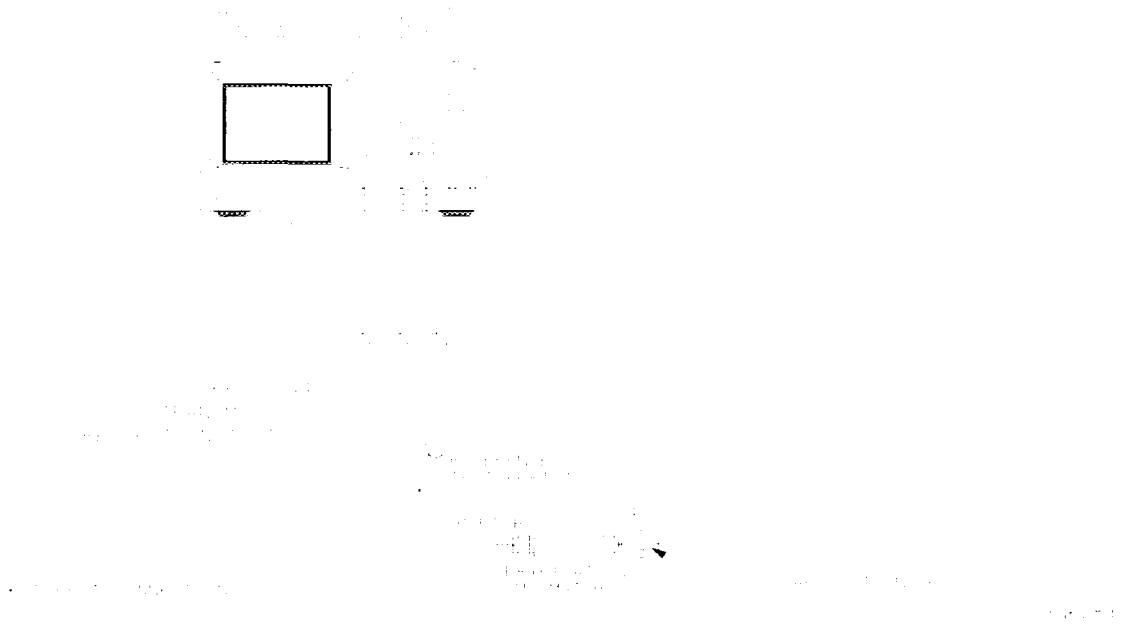

Figure 5-14. Mismatch Device Verification Setup

- 9 Press *RETURN*, *TESTS*, 31, x1, *EXECUTE TEST*, *CONTINUE*.
- 10 You have completed the system verification procedure when the analyzer displays, Ver Def 4 PASS.

In Case of Difficulty

- 1** Inspect all connections. Do *not* disconnect the cables from the analyzer test ports. Doing so will invalidate the calibration that you have done earlier.
- 2** Recall the measurement calibration and repeat the procedure:
 - a** Press PRESET, SAVE/RECALL, *SELECT DISK*, *INTERNAL DISK*, RETURN.
 - b** Using the front panel knob, highlight the title of the one-path 2-port calibration that you have done earlier.
 - c** Press *RECALL STATE*.
 - d** Repeat “Step 3. Device Verification” on page 5-19.
- 3** If the analyzer still fails the test, check the measurement calibration as follows:
 - a** Press PRESET.
 - b** Recall the calibration by pressing SAVE/RECALL, *SELECT DISK*, *INTERNAL DISK*, RETURN.
 - c** Use the front panel knob to highlight the calibration you want to recall and press *RECALL STATE*.
 - d** Connect the short to reference test port 1.
 - e** Press SCALE REF, *SCALE/DIV*, .01, x1.
 - f** Check that the trace response is 0.00 ± 0.05 dB.
 - g** Disconnect the short and connect it to reference test port 2.
 - h** Press MEAS, *Ref: E S11 FWD*.
 - i** Check that the trace response is 0.00 ± 0.05 dB.
 - j** If any of the trace responses are out of the specified limits, repeat the “Measurement Calibration” and “Device Verification” procedures.
- 4** Refer to the *HP 8753D Option 011 Service Guide* for more troubleshooting information.

Performance Tests – Option 011

Manual Performance Tests - Option 011

This chapter contains procedures which test the electrical performance of the HP 8702D Option 011. If you are *not* using an HP 8702D Option 011, refer to Chapter 4, “Performance Tests”. Before starting these procedures, allow the instrument to warm up for one hour.

Each procedure has a “Performance Test Record” that is located at the end of this chapter.

To obtain the same quality of performance testing that Hewlett-Packard has administered at the factory, you must perform:

- the system verification procedures in Chapter 5, “Automated Verification – Option 011”.
- *all* of the performance test procedures in this chapter.

This quality of performance testing guarantees that the analyzer is performing within *all* of the published specifications. Hewlett-Packard will issue a Certificate of Calibration for your analyzer if two conditions are met.

- 1 Your analyzer passes all the performed tests.
- 2 The equipment and standards that you used to perform the tests are traceable to a national standards institute.

NOTE

If you have a particular type of measurement application that does *not* use all of the analyzer’s measurement capabilities, you may ask your nearest Hewlett-Packard Sales and Service Office for a subset of specifications that you want verified. However, this does create a potential for making incorrect measurements, by using a different application than what was specified.

WARNING

Any servicing, adjustment, maintenance, or repair of this product must be performed only by qualified personnel. Repair information provided in the *In Case of Difficulty* sections of this chapter are provided for qualified service personnel and are intended to be used with the HP 8753D Service Guide.

HP 8753D is shown in the figures

The procedures in this chapter are designed to work with HP 8702D and HP 8753D instruments. Because of this, many of the figures label the instrument being tested as an HP 8753D. Simply substitute your HP 8702D for the HP 8753D.

What you'll find in this chapter

1. Source Frequency Range and Accuracy 6-4
 2. Source Power Range, Linearity, and Accuracy 6-6
 3. Receiver Minimum R Channel Level 6-12
 4. Receiver Minimum R Channel Level for External Source Mode 6-15
 5. Receiver Channel Noise Floor Level (Only for Analyzers without Option 006) 6-18
 6. Receiver Channel Noise Floor Level (Only for Analyzers with Option 006) 6-21
 7. Receiver Magnitude Frequency Response 6-25
 8. Receiver Phase Frequency Response 6-29
 9. Receiver Input Crosstalk 6-32
 10. Receiver Trace Noise 6-38
 11. Receiver Input Impedance 6-40
 12. Receiver Magnitude Dynamic Accuracy 6-45
 13. Receiver Phase Dynamic Accuracy 6-53
 14. Receiver Magnitude Compression 6-55
 15. Receiver Phase Compression 6-63
 16. Source and Receiver Harmonics (Option 002 Only) 6-70
 17. Receiver Magnitude Frequency Response (Option 002 Only) 6-75
- Performance Test Records - Option 011 6-78

1. Source Frequency Range and Accuracy

1. Source Frequency Range and Accuracy

Perform this test to verify the frequency accuracy of the analyzer over its entire operating frequency range.

Required Equipment

Frequency Counter	HP 5343A
RF Cable Set, 50Ω, Type-N	HP 11851B
2-way Power Splitter	HP 11667A Option 001
Adapter, APC-3.5 (f) to Type-N (f)	HP P/N 1250-1745
Adapter, Type-N (f) to BNC (m)	HP P/N 1250-0077

Procedure

- 1 Connect the equipment as shown in Figure 6-1.

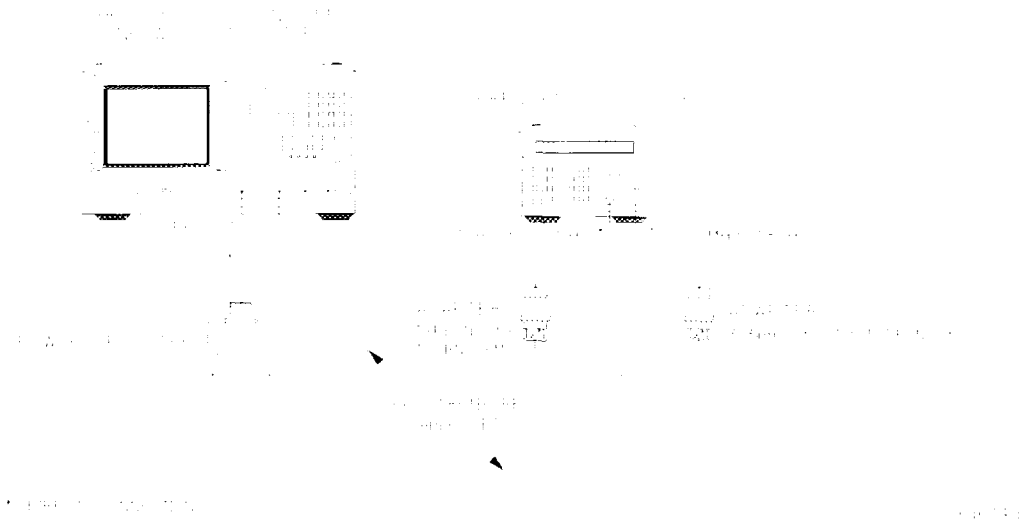

Figure 6-1. Source Frequency Range and Accuracy Test Setup

- 2 Press **PRESET**, **MENU**, **CW FREQ**.
- 3 Press 300, k/m and write the frequency counter reading on the "Performance Test Record."
- 4 Repeat Step 3 for each instrument frequency listed in the "Performance Test Record."

1. Source Frequency Range and Accuracy**In Case of
Difficulty**

- 1** If any measured frequency is close to the specification limits, check the time base accuracy of the counter used.
- 2** If the analyzer fails by a significant margin at *all* frequencies (especially if the deviation increases with frequency), the master time base probably needs adjustment. In this case, refer to “Frequency Accuracy Adjustment” in the “Adjustments and Correction Constants” chapter in the *HP 8753D Option 011 Service Guide*. The “Fractional-N Frequency Range Adjustment” could also affect the frequency accuracy.
- 3** Refer to the *HP 8753D Option 011 Service Guide* for further troubleshooting information.

2. Source Power Range, Linearity, and Accuracy

2. Source Power Range, Linearity, and Accuracy

Perform this test to verify the analyzer's power range and linearity at different CW frequencies throughout the analyzer operating frequency range.

**Required
Equipment**

Power Meter	HP 436A437B/438A
Power Sensor	HP 8482A
2-way Power Splitter (2), 50Ω	HP 11667A Option 001
Attenuator (2), 20 dB	HP 8491A Option 020
RF Cable Set, 50Ω, Type-N	HP 11851B

Additional Required Equipment for Analyzers with Option 006

Power Sensor	HP 8481A
--------------------	----------

2. Source Power Range, Linearity, and Accuracy**Procedure*****Path loss calibration***

- 1 Connect the equipment as shown in Figure 6-2.

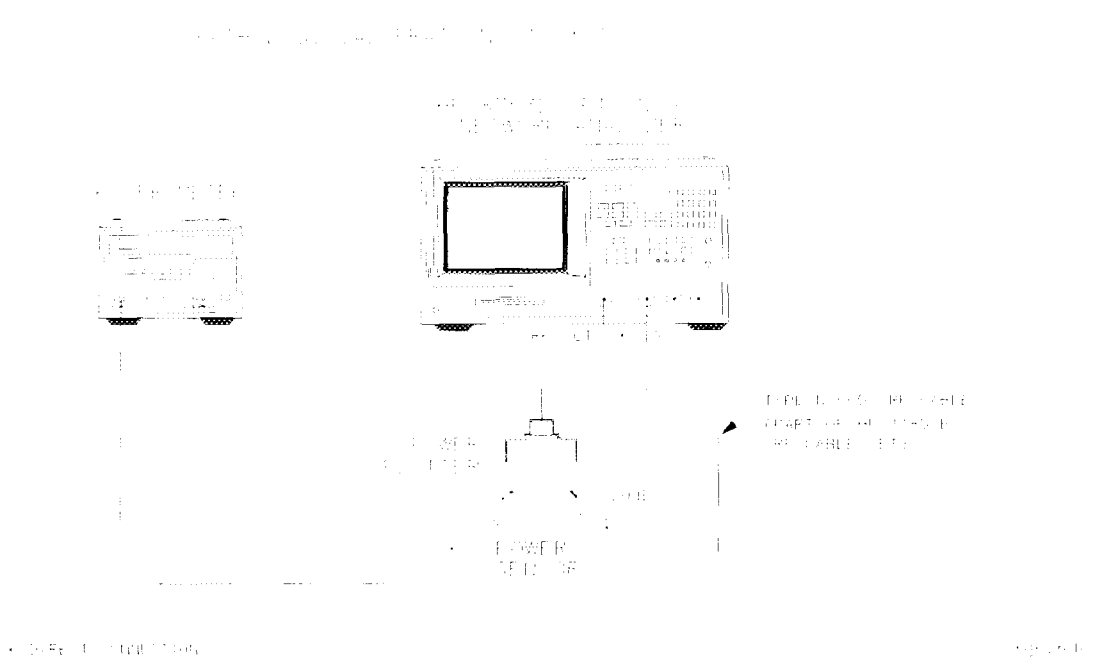
**Figure 6-2. Path Loss Calibration Test Setup (#1)**

- 2 Zero and calibrate the power meter. Also, set the power meter for dBm. Refer to the power meter operating and service manual for more information on how to do this task.
- 3 Press PRESET, MENU, *POWER*, 10, x1.
- 4 Press MENU, *CW FREQ*, 300, k/m. Set the power meter calibration factor for this CW frequency (except if you are using an HP 436A).
- 5 Write the power meter reading in the “First Value” column on the “Performance Test Record”.
- 6 Repeat Step 4 and Step 5 for the other CW frequencies listed on the “Performance Test Record”.

2. Source Power Range, Linearity, and Accuracy

- 7 Connect the equipment as shown in Figure 6-3.

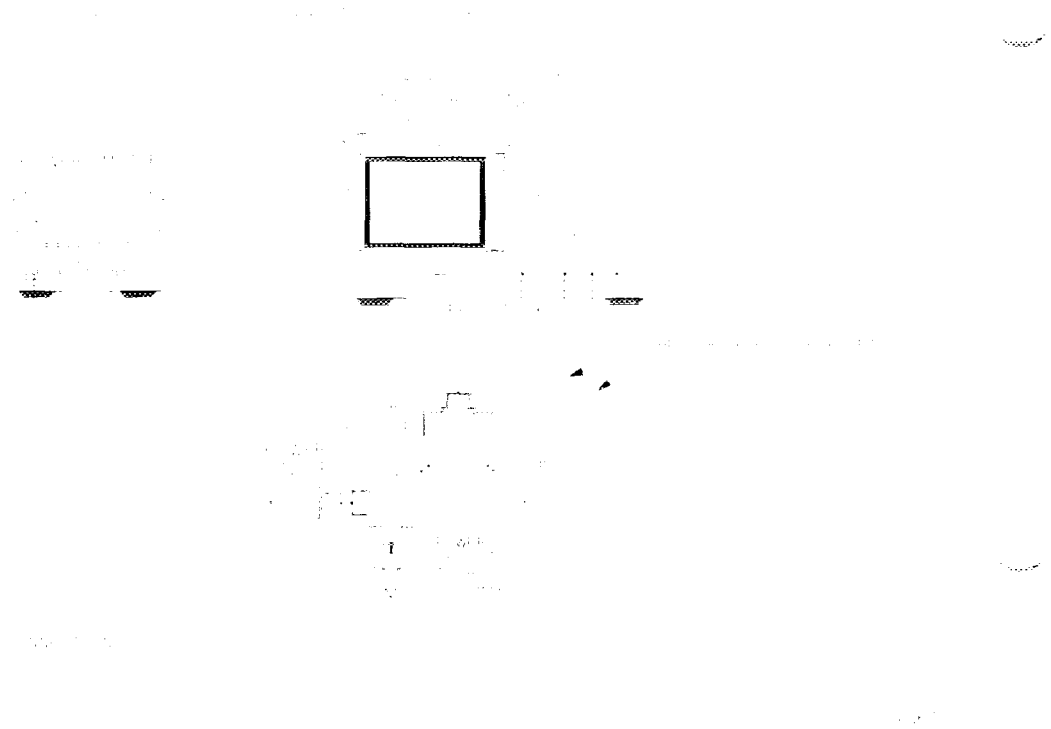

Figure 6-3. Path Loss Calibration Test Setup (#2)

- 8 Press MENU, *CWFREQ*, 300, k/m. Set the power meter calibration factor for this CW frequency.
- 9 Write the power meter reading in the "Second Value" column on the "Performance Test Record."
- 10 Calculate the path loss through the power splitter with this formula:
- $$\text{First Value} - \text{Second Value} = \text{Path Loss}$$
- 11 Write the result on the "Performance Test Record."
- 12 Repeat Step 8 through Step 11 for the other CW frequencies listed on the "Performance Test Record."

2. Source Power Range, Linearity, and Accuracy***Power range and power linearity***

- 13** Connect the equipment as shown in Figure 6-4.

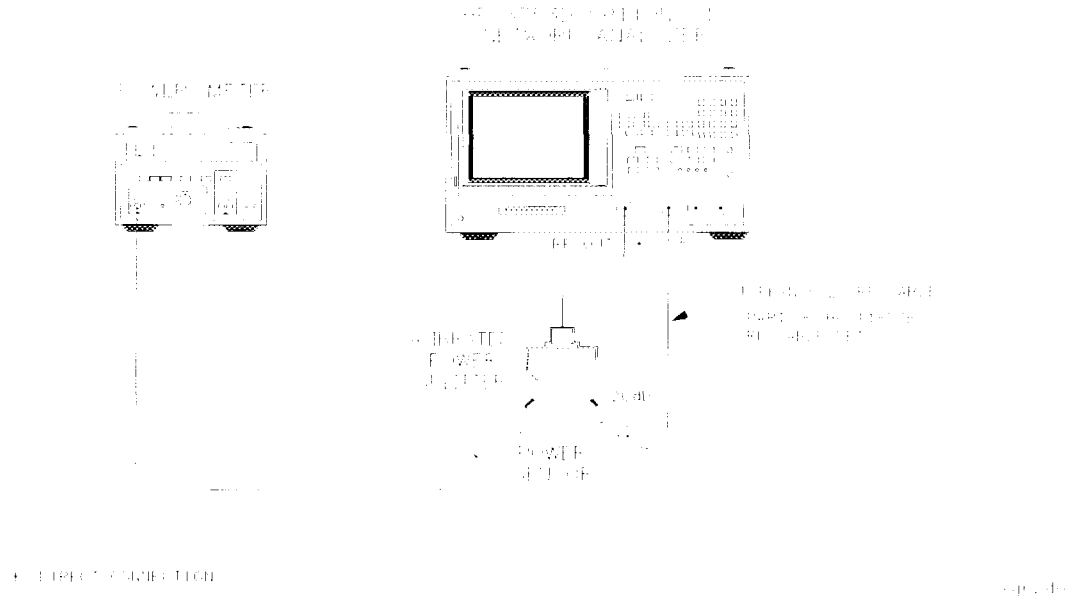

Figure 6-4. Power Range, Linearity, and Accuracy Test Setup

- 14** Press PRESET, MENU, *CW FREQ*, 300, k/m. Set the power meter calibration factor for this CW frequency.
- 15** Press *POWER*, 10, x1. On the power meter, set the current power level as the reference for relative power (dB) measurements. This can be done by either pressing dB REL on an HP 436A, or REL on an HP 438A power meter front panel.
- 16** Press *POWER*, -5, x1. Write the power meter reading in the “Measured Value” column on the “Performance Test Record”.
- 17** On the “Performance Test Record”, copy the “Path Loss” value, previously calculated for this CW frequency, into the “Pass Loss” column.
- 18** With the power offset value that is listed in the “Performance Test Record”, calculate the power linearity using this formula:

$$\text{Power Linearity} = [\text{Power Offset} + \text{Path Loss}] + [\text{Measured Value}]$$

2. Source Power Range, Linearity, and Accuracy

- 19 Write the result of your calculation on the “Performance Test Record”.
- 20 Repeat Step 15 through Step 19 for the other source power levels listed on the “Performance Test Record”.
- 21 Press MENU, *CWFREQ*, 3, G/n.
- 22 Press *POWER*, 10, x1. Set the power meter calibration factor for the selected CW frequency. Press the appropriate hardkey (dB REL or REL) on the HP 436A/438A power meter front panel for relative power measurements.
- 23 Press *POWER*, -5, x1. Write the power meter reading in the “Measured Value” column on the “Performance Test Record”.
- 24 On the “Performance Test Record”, copy the “Path Loss” value, previously calculated for the CW frequency, into the “Pass Loss” column.
- 25 With the power offset value listed in the “Performance Test Record”, calculate the source power level linearity using this formula:

$$\text{Power Linearity} = [\text{Power Offset} + \text{Path Loss}] + [\text{Measured Value}]$$

- 26 Write the result of your calculation on the “Performance Test Record”.
- 27 Repeat Step 23 through Step 26 for the other power levels listed on the “Performance Test Record”.

For analyzers with Option 006

- 28 Press MENU, *CWFREQ*, 6, G/n.
- 29 Repeat Step 22 through Step 26 for the other power levels listed on the “Performance Test Record”.

Power level accuracy

- 30 Press MENU, *POWER*, 10, x1.
- 31 Press MENU, *CWFREQ*, 300, k/m. Set the power calibration factor for this CW frequency.
- 32 On the “Performance Test Record”, copy the “Path Loss” value, previously calculated for this CW frequency, into the “Pass Loss” column.
- 33 Calculate the calibrated source power level using this formula:

$$\text{Calibrated Power Level} = 10 - \text{Loss}$$

- 34 Write the result in the “Calibrated Power Level” column.

2. Source Power Range, Linearity, and Accuracy

- 35** Write the power meter reading under the “Measured Value” column on the “Performance Test Record”.
- 36** Calculate the power level accuracy using this formula:
$$\text{Calibrated Power Level} - \text{Measured Value} = \text{Power Level Accuracy}$$
- 37** Write this value on the “Performance Test Record”.
- 38** Repeat Step 31 through Step 37 for the other CW frequencies listed on the “Performance Test Record”.

**In Case of
Difficulty**

- 1** Ensure that the power meter and power sensor are operating to specification.
- 2** Inspect the power splitter connectors. Poor match at these connections can generate power reflections that can cause the analyzer to appear to be out of specification.
- 3** Inspect the analyzer RF OUT connector for damage.
- 4** If any test fails, perform the “RF Output Power Correction Constants (Test 47)”, located in the “Adjustments and Correction Constants” chapter of the *HP 8753D Option 011 Service Guide*.

3. Receiver Minimum R Channel Level

3. Receiver Minimum R Channel Level

Perform this test to verify the minimum R channel input power level at which phase lock can be accomplished.

Required Equipment

Adapter, APC-3.5 (m) to APC-7	HP P/N 1250-1746
Cable, APC-7 24-inch	HP P/N 8120-4779
Attenuator, 20 dB	HP 8491A Option 020
Attenuator, 30 dB	HP 8491A Option 030

Procedure

- 1 Connect the equipment as shown in Figure 6-5.

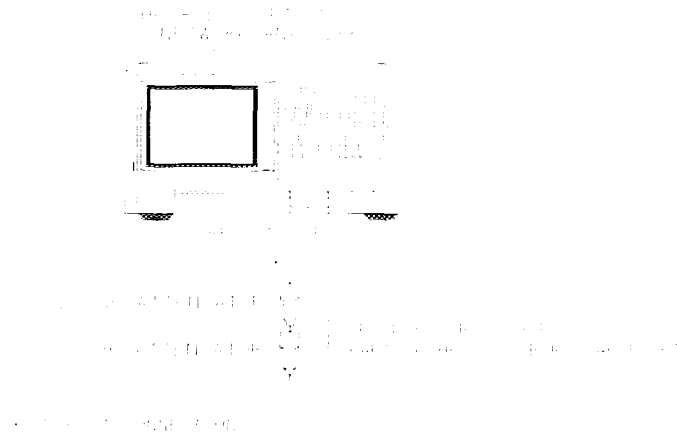

Figure 6-5. Receiver Minimum R Channel Level Test Setup

- 2 Press PRESET, MEAS, *INPUT PORTS*, *R*.
- 3 Press MARKER FCTN, *MARKER MODE MENU*, *MKR SEARCH*, *TRACKING ON*, *SEARCH:MAX* to locate the maximum value of the R channel input signal.
- 4 Press MENU, *POWER*, *-5*, *x1*.
- 5 Press MENU, *CW FREQ*, *300*, *k/m*.

3. Receiver Minimum R Channel Level

- 6** Check the analyzer display for phase lock error messages:
- If you do *not* observe a phase lock error message, write the marker value read-out (which appears in the analyzer display) in the “Performance Test Record”.
 - If you do observe a phase lock message:
 - a** Press MENU, *POWER*, ↑ to increase the power by 1 dBm.
 - b** Check the analyzer for phase lock error messages.
 - c** If the analyzer still doesn't phase lock, continue increasing the source output power until phase lock is achieved.
 - d** Write the marker value in the “Performance Test Record”.
 - Repeat Step 4 through Step 6 for the other CW frequencies listed in the “Performance Test Record”.

In Case of Difficulty**WARNING**

These servicing instructions are for use by qualified personnel only. To avoid electrical shock, do not perform any servicing unless you are qualified to do so.

WARNING

The opening of covers or removal of parts is likely to expose dangerous voltages. Disconnect the instrument from all voltage sources while it is being opened.

WARNING

The power cord is connected to internal capacitors that may remain live for five seconds after disconnecting the plug from its power supply.

- 1** Check the flexible RF cable between the R sampler assembly and the A11 phase lock assembly. Make sure it is connected between A11J1 (PL IF IN) and 1st IF Out.
- 2** Using an ohmmeter, verify that the RF cable is *not* open. In addition, examine both the cable connectors - measure the resistance between the cable center pin and the cable connector. The ohmmeter should display a high resistance reading.
- 3** Check the R sampler by substituting it with the A sampler and rerun the test.
 - a** Move cable W8 to the A sampler.
 - b** Use a 10 dB attenuator between the RF OUT and input A.

3. Receiver Minimum R Channel Level

- c** Repeat the test.
 - d** Select the A sampler by pressing MEAS, *INPUT PORTS*, A in Step 2.
 - e** If the test fails, replace the A11 assembly.
- 4** Verify that the high/low band adjustments are still within specifications. For more information on how to perform this task, refer to the "High/Low Band Transition Adjustment", located in the "Adjustments and Correction Constants" chapter in the *HP 8753D Option 011 Service Guide*.
- 5** Refer to the *HP 8753D Option 011 Service Guide* for more troubleshooting information.

4. Receiver Minimum R Channel Level for External Source Mode

4. Receiver Minimum R Channel Level for External Source Mode

Perform this test to verify proper phase lock in the external source mode, as the specified minimum R input level of -25 dBm.

Required Equipment

- External source HP 83640A
- Adapter, APC-3.5 (f) to Type-N (f) HP P/N 1820-1745
- Cable, 50Ω, Type-N HP 11851B
- Attenuator, 10 dB HP 8491A Option 010
- Attenuator, 20 dB HP 8491A Option 020

Procedure

- 1 Connect the equipment as shown in Figure 6-6.

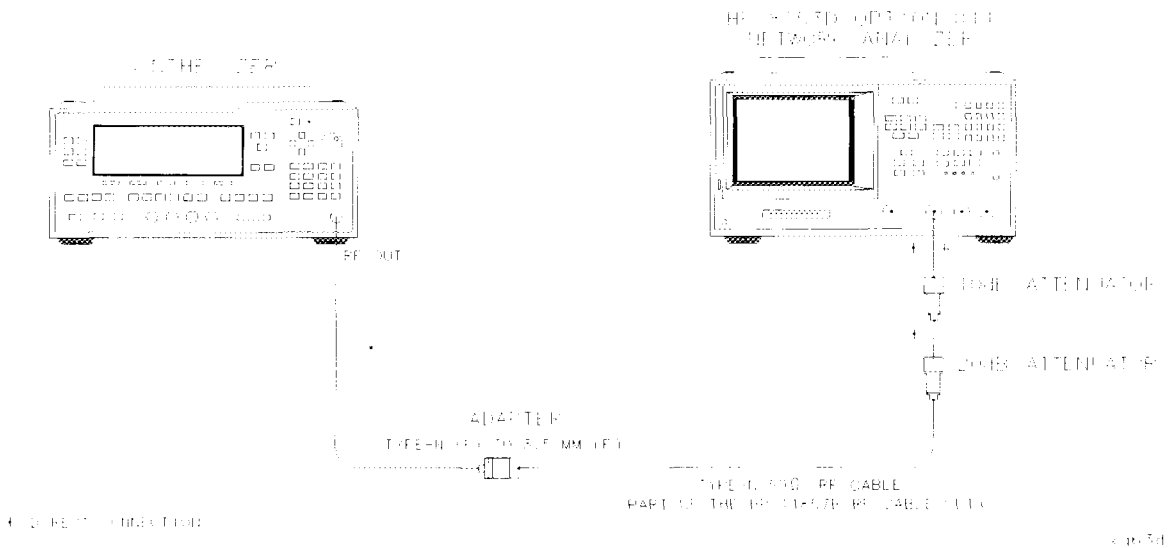

Figure 6-6. Receiver Minimum R Channel Level for External Source Test Setup

- 2 On the external source, press PRESET, *POWER LEVEL*, 4, dB(m), *CW*, 10, MHz.

4. Receiver Minimum R Channel Level for External Source Mode

- 3 On the analyzer, press PRESET, MENU, *CW FREQ*, 10, M/ μ , SYSTEM, *INSTRUMENT MODE*, *EXT SOURCE AUTO* to set up the analyzer for an external source input to the receiver channel R.
- 4 Press SYSTEM, *SERVICE MENU*, *ANALOG BUS ON*, MEAS, *S PARAMETERS*, *ANALOG IN Aux Input*, 29, x1, *COUNTER: FRAC N*, MEAS, *INPUT PORTS: R*, to set up the analog bus counter to measure the frequency of the fractional-N VCO.
- 5 Press MARKER FCTN, *MARKER MODE MENU*, *MKR SEARCH*, *TRACKING ON*, *SEARCH:MAX* to observe the maximum value of the receiver R input signal.
- 6 The analyzer marker 1 should read –26 dBm (which appears on the analyzer display). If the marker value exceeds –26 dBm, press *POWER LEVEL* on the external source and decrease the power until the marker 1 reads –26 dBm.
- 7 Press MARKER FCTN, *MARKER MODE MENU*, *MKR SEARCH*, *SEARCH:OFF*.
- 8 Write the analog bus counter reading (which appears on the analyzer display) on the “Performance Test Record”.

NOTE

The analyzer is phase-locked if the analog bus counter reading is within the limits shown on the “Performance Test Record”.

- 9 On the external source, press *CW*, 20, MHz.
- 10 On the analyzer, press MENU, *CW FREQ*, 20, M/ μ . If the analyzer’s marker value readout exceeds –26 dBm, reduce the external source power level. Write the analog bus counter reading and compare it with the acceptable limits on the “Performance Test Record”.
- 11 Repeat Step 9 and Step 10 for the CW frequencies listed on the “Performance Test Record”.

4. Receiver Minimum R Channel Level for External Source Mode**In Case of
Difficulty**

WARNING

These servicing instructions are for use by qualified personnel only. To avoid electrical shock, do not perform any servicing unless you are qualified to do so.

WARNING

The opening of covers or removal of parts is likely to expose dangerous voltages. Disconnect the instrument from all voltage sources while it is being opened.

WARNING

The power cord is connected to internal capacitors that may remain live for five seconds after disconnecting the plug from its power supply.

- 1** Check the R sampler assembly by substituting it with the A sampler assembly.
- 2** Move the flexible RF cable (currently connected to the R sampler assembly) to the A sampler assembly.
- 3** Use a 10 dB attenuator between the RF OUT and the analyzer receiver input A.
- 4** Repeat the test. In Step 4, press MEAS, *INPUT PORTS*, A.
- 5** If the test still fails, suspect the A11 phase lock board assembly.

5. Receiver Channel Noise Floor Level (Only for Analyzers without Option 006)

5. Receiver Channel Noise Floor Level (Only for Analyzers without Option 006)

Perform this test to determine the analyzer receiver channel noise floor levels.

Required Equipment

Attenuator, 20 dB HP 8491A Option 020
Termination (2), 50 Ω HP 908A
Cable, 50 Ω , Type-N, 24 inch HP 11851B

Procedure

- 1 Connect the equipment as shown in Figure 6-7.

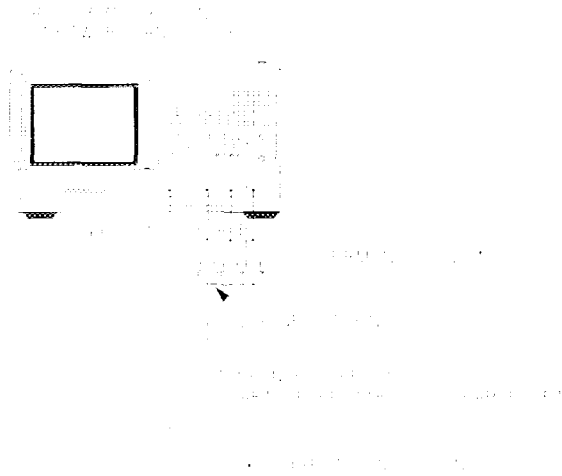

Figure 6-7. Receiver Channel Noise Floor Level Test Setup

- 2 Press PRESET, MENU, POWER, -10, x1.

Receiver Channel A Noise Floor Level with a 3 kHz IF BW

- 3 Press MEAS, INPUT PORTS, A, FORMAT, LIN MAG, SCALE REF, AUTO SCALE.
- 4 Press MARKER FCTN, MARKER MODE MENU, STATS ON, MENU, TRIGGER MENU, SINGLE.

5. Receiver Channel Noise Floor Level (Only for Analyzers without Option 006)

- 5 When the analyzer finishes the sweep, notice the mean value, which appears on the analyzer display.
- 6 Use the following equation to convert the linear magnitude mean value to log amplitude:

$$\text{Power (dBm)} = 20 * [\log_{10}(\text{linear magnitude mean value})]$$

- 7 Write this calculated value in the “Performance Test Record” in dBm.

Receiver Channel A Noise Floor Level with a 10 Hz IF BW

- 8 Press AVG, *IF BW*, 10, x1 to change the IF bandwidth to 10 Hz.
- 9 Press MENU, *TRIGGER MENU*, *SINGLE*.
- 10 When the analyzer finishes the sweep, notice the mean value, which appears on the analyzer display.
- 11 Use the following equation to convert the linear magnitude mean value to log magnitude:

$$\text{Power (dBm)} = 20 * [\log_{10}(\text{linear magnitude mean value})]$$

- 12 Write this calculated value in the “Performance Test Record” in dBm.

Receiver Channel B Noise Floor Level with 10 Hz IF BW

- 13 Press MEAS, *INPUT PORTS*, *B*, *FORMAT*, *LIN MAG*.
- 14 Press MENU, *TRIGGER MENU*, *SINGLE*.
- 15 When the analyzer finishes the sweep, notice the mean value, which appears on the analyzer display.
- 16 Use the following equation to convert the linear magnitude mean value to log magnitude:

$$\text{Power (dBm)} = 20 * [\log_{10}(\text{linear magnitude mean value})]$$

- 17 Write this calculated value in the “Performance Test Record” in dBm.

Receiver Channel B Noise Floor Level with a 3 kHz IF BW

- 18 Press AVG, *IF BW*, 3, k/m to change the IF bandwidth to 3 kHz.
- 19 Press MENU, *TRIGGER MENU*, *SINGLE*.
- 20 When the analyzer finishes the sweep, record the mean value, which appears on the analyzer display.

5. Receiver Channel Noise Floor Level (Only for Analyzers without Option 006)

- 21** Use the following equation to convert the linear magnitude mean value to log magnitude:

$$Power (dBm) = 20 * [\log_{10}(linear\ magnitude\ mean\ value)]$$

- 22** Write this calculated value in the “Performance Test Record” in dBm.

**In Case of
Difficulty**

- 1** Perform the “ADC Offset Correction Constants (Test 52),” located in the “Adjustments” chapter in the *HP 8753D Option 011 Service Guide*.
- 2** Suspect the A10 digital IF assembly if *both* receiver channels fail.
- 3** Refer to the *HP 8753D Option 011 Service Guide* for further troubleshooting information.

6. Receiver Channel Noise Floor Level (Only for Analyzers with Option 006)**6. Receiver Channel Noise Floor Level (Only for Analyzers with Option 006)**

Perform this test to determine the analyzer receiver channel noise floor levels.

Required Equipment

Attenuator, 20 dB HP 8491A Option 020
 Termination (2), 50 Ω HP 908A
 Cable, 50 Ω , Type-N, 24 inch HP 11851B

Procedure

- 1 Connect the equipment as shown in Figure 6-8.

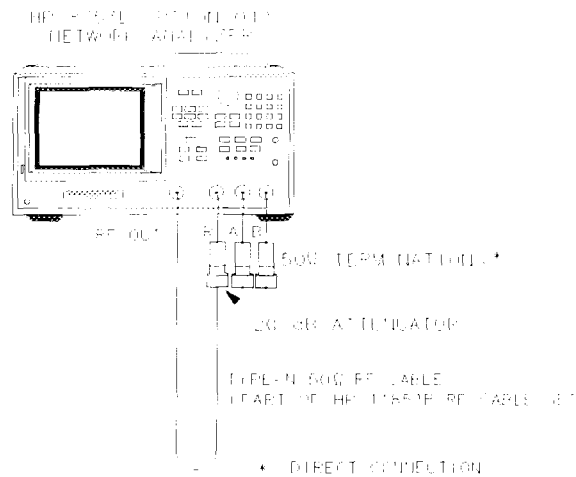

6-11

Figure 6-8. Receiver Channel Noise Floor Level Test Setup

- 2 Press PRESET, START, 50, k/m, STOP, 3, G/n, MENU, POWER, -10, x1.

Receiver Channel A Noise Floor Level with a 3 kHz IF BW (50 kHz–3 GHz)

- 3 Press MEAS, INPUT PORTS, A, FORMAT, LIN MAG, SCALE REF, AUTO SCALE.

6. Receiver Channel Noise Floor Level (Only for Analyzers with Option 006)

- 4 Press MARKER FCTN, *MARKER MODE MENU*, *STATS ON. MENU*, *TRIGGER MENU*, *SINGLE*.
- 5 When the analyzer finishes the sweep, notice the mean value, which appears on the analyzer display.
- 6 Use the following equation to convert the linear magnitude mean value to log amplitude:

$$Power (dBm) = 20 * [\log_{10}(\text{linear magnitude mean value})]$$

- 7 Write this calculated value in the “Performance Test Record” in dBm.

***Receiver Channel A Noise Floor Level with a 10 Hz IF BW
(50 kHz–3 GHz)***

- 8 Press AVG, *IF BW*, 10, x1 to change the IF bandwidth to 10 Hz.
- 9 Press MENU, *TRIGGER MENU*, *SINGLE*.
- 10 When the analyzer finishes the sweep, notice the mean value, which appears on the analyzer display.
- 11 Use the following equation to convert the linear magnitude mean value to log magnitude:

$$Power (dBm) = 20 * [\log_{10}(\text{linear magnitude mean value})]$$

- 12 Write this calculated value in the “Performance Test Record” in dBm.

***Receiver Channel B Noise Floor Level with 10 Hz IF BW
(50 kHz–3 GHz)***

- 13 Press MEAS, *INPUT PORTS*, B, *FORMAT*, *LIN MAG*.
- 14 Press MENU, *TRIGGER MENU*, *SINGLE*.
- 15 When the analyzer finishes the sweep, notice the mean value, which appears on the analyzer display.
- 16 Use the following equation to convert the linear magnitude mean value to log magnitude:

$$Power (dBm) = 20 * [\log_{10}(\text{linear magnitude mean value})]$$

- 17 Write this calculated value in the “Performance Test Record” in dBm.

6. Receiver Channel Noise Floor Level (Only for Analyzers with Option 006)***Receiver Channel B Noise Floor Level with a 3 kHz IF BW
(50 kHz–3 GHz)***

- 18 Press AVG, *IF BW*, 3, k/m to change the IF bandwidth to 3 kHz.
- 19 Press MENU, *TRIGGER MENU*, *SINGLE*.
- 20 When the analyzer finishes the sweep, record the mean value, which appears on the analyzer display.
- 21 Use the following equation to convert the linear magnitude mean value to log magnitude:

$$\text{Power (dBm)} = 20 * [\log_{10}(\text{linear magnitude mean value})]$$

- 22 Write this calculated value in the “Performance Test Record” in dBm.

***Receiver Channel B Noise Floor Level with 3 kHz IF BW
(3 GHz–6 GHz)***

- 23 Press START, 3, G/n, STOP, 6, G/n.
- 24 Press MENU, *TRIGGER MENU*, *SINGLE*.
- 25 When the analyzer finishes the sweep, record the mean value, which appears on the analyzer display.
- 26 Use the following equation to convert the linear magnitude mean value to log magnitude:

$$\text{Power (dBm)} = 20 * [\log_{10}(\text{linear magnitude mean value})]$$

- 27 Write this calculated value in the “Performance Test Record” in dBm.

***Receiver Channel B Noise Floor Level with 10 Hz IF BW
(3 GHz–6 GHz)***

- 28 Press AVG, *IF BW*, 10, x1 to change the IF bandwidth to 10 Hz.
- 29 Press MENU, *TRIGGER MENU*, *SINGLE*.
- 30 When the analyzer finishes the sweep, record the mean value, which appears on the analyzer display.
- 31 Use the following equation to convert the linear magnitude mean value to log magnitude:

$$\text{Power (dBm)} = 20 * [\log_{10}(\text{linear magnitude mean value})]$$

- 32 Write this calculated value in the “Performance Test Record” in dBm.

6. Receiver Channel Noise Floor Level (Only for Analyzers with Option 006)

***Receiver Channel A Noise Floor Level with 10 Hz IF BW
(3 GHz–6 GHz)***

- 33 Press MEAS, *INPUT PORTS*, A.
- 34 Press MENU, *TRIGGER MENU*, *SINGLE*.
- 35 When the analyzer finishes the sweep, record the mean value, which appears on the analyzer display.
- 36 Use the following equation to convert the linear magnitude mean value to log magnitude:

$$\text{Power (dBm)} = 20 * [\log_{10}(\text{linear magnitude mean value})]$$

- 37 Write this calculated value in the “Performance Test Record” in dBm.

***Receiver Channel A Noise Floor Level with 3 kHz IF BW
(3 GHz–6 GHz)***

- 38 Press AVG, *IF BW*, 3, k/m.
- 39 Press MENU, *TRIGGER MENU*, *SINGLE*.
- 40 When the analyzer finishes the sweep, record the mean value, which appears on the analyzer display.
- 41 Use the following equation to convert the linear magnitude mean value to log magnitude:

$$\text{Power (dBm)} = 20 * [\log_{10}(\text{linear magnitude mean value})]$$

- 42 Write this calculated value in the “Performance Test Record” in dBm.

**In Case of
Difficulty**

- 1 Perform the “ADC Offset Correction Constants (Test 52),” located in the “Adjustments” chapter in the *HP 8753D Option 011 Service Guide*.
- 2 Suspect the A10 digital IF assembly if *both* receiver channels fail.
- 3 Refer to the *HP 8753D Option 011 Service Guide* for further troubleshooting information.

7. Receiver Magnitude Frequency Response

Perform this test to verify how well the analyzer transfers information from the RF to IF, and how accurately it processes and displays that information.

Required Equipment

Power Meter	HP 436A/437B/438A
Power Sensor	HP 8482A
2-way Power Splitter, 50Ω	HP 11667A Option 001
Attenuator, 10 dB	HP 8491A Option 010
RF cable set, 50Ω, Type-N	HP 11851B
Adapter, Type-N (m) to Type-N (m)	HP P/N 1250-1475
Adapter, Type-N (f) to Type-N (f)	HP P/N 1250-1472

Additional Equipment Required for Analyzers with Option 006

Power Sensor	HP 8481A
--------------------	----------

Procedure

Input R Magnitude Frequency Response

- 1 Connect the equipment as shown in Figure 6-9.

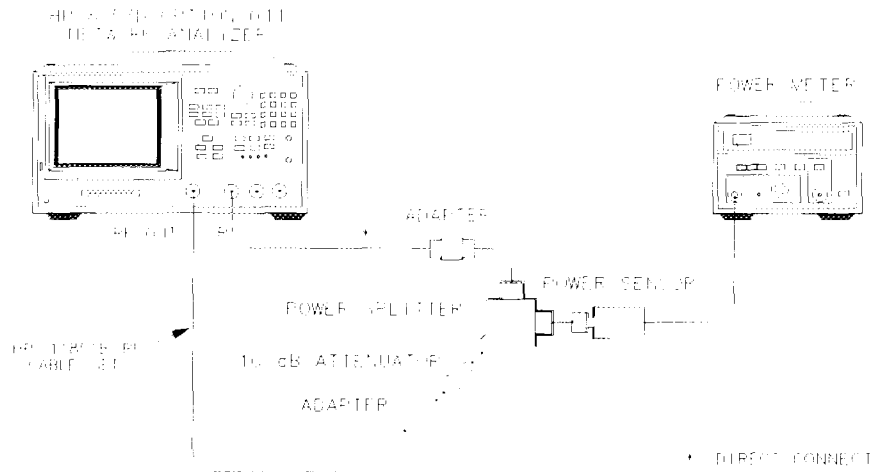

Figure 6-9. Magnitude Frequency Response Test Setup (Receiver Input R)

7. Receiver Magnitude Frequency Response

- 2 Zero and calibrate the power meter. Set it to measure dBm.
- 3 Press PRESET, MARKER, MEAS, *INPUT PORTS*, R, MENU, *POWER*, 6, x1.
- 4 Press *CW FREQ*, 300, k/m. Set the calibration factor on the power meter for this CW frequency.
- 5 Write the power meter reading on the “Performance Test Record.”
- 6 Write the marker reading, which appears on the analyzer display, in the “R Input Power” column of the “Performance Test Record.”
- 7 Repeat Step 4 through Step 6 for the other CW frequencies listed on the “Performance Test Record.”

Input A Magnitude Frequency Response

- 8 Connect the equipment as shown in Figure 6-10.

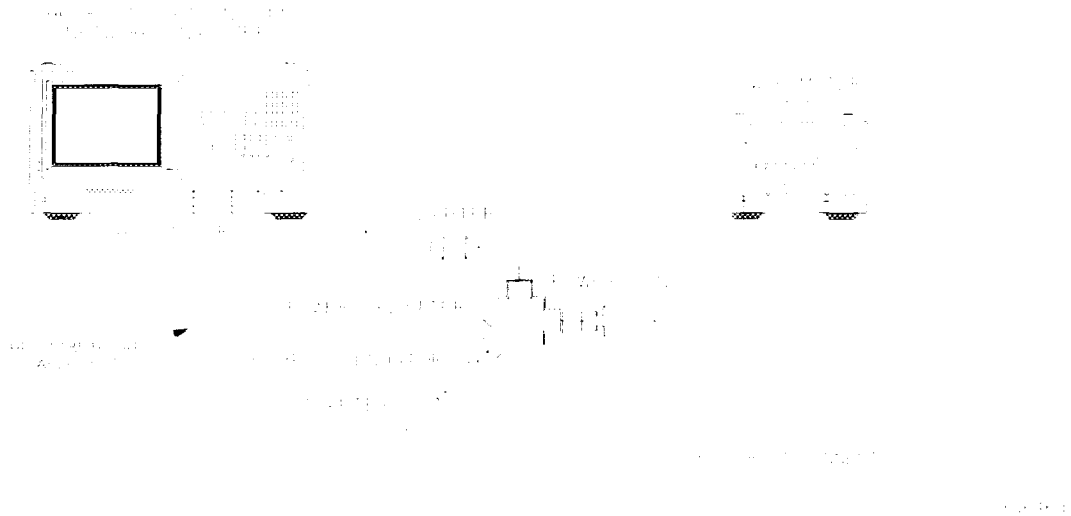

Figure 6-10. Magnitude Frequency Response Test Setup (Receiver Input A)

- 9 Press MEAS, *INPUT PORTS*, A, MENU to measure the power at the receiver input A channel.
- 10 Press *CW FREQ*, 300, k/m.
- 11 Write the marker reading, which appears on the analyzer display, in the “A Input Power” column of the “Performance Test Record.”
- 12 Repeat Step 10 and Step 11 for the other CW frequencies listed on the “Performance Test Record.”

7. Receiver Magnitude Frequency Response***Input B Magnitude Frequency Response***

13 Connect the equipment as shown in Figure 6-11.

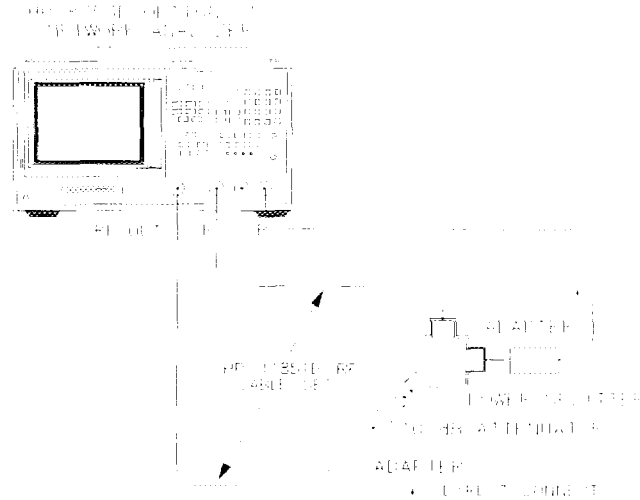

Figure 6-11. Magnitude Frequency Response Test Setup (Receiver Input B)

- 14** Press MEAS, *INPUT PORTS*, *B*, MENU to start measuring the power delivered to receiver input B.
- 15** Press *CWFREQ*, 300, k/m.
- 16** Write the marker reading, which appears on the analyzer display, in the “B Input Power” column of the “Performance Test Record.”
- 17** Repeat Step 15 and Step 16 for the other CW frequencies listed on the “Performance Test Record.”
- 18** For each CW frequency, determine which channel input reading shows the greatest difference:
 - power meter versus R
 - power meter versus A
 - power meter versus B

Refer to the first line for an example listed in the “Performance Test Record.” Write the greatest difference in the space provided on the “Performance Test Record.”

7. Receiver Magnitude Frequency Response

NOTE

The final results represent the worst case magnitude frequency response for all the analyzer receiver inputs at the selected frequencies.

In Case of Difficulty

- 1 Suspect poor tracking between the ports of the power splitter if *all* receiver inputs fail. Try to repeat the test with another power splitter.
- 2 Suspect source drift if receiver inputs A and B fail this test at *any* frequency. Connect the equipment as shown in Figure 6-10 (or Figure 6-11), set the analyzer source power at the frequency of interest. Repeat the test for the receiver input(s) that failed before.
- 3 Perform the “Sampler Magnitude and Phase Correction Constants (Test 53)” procedure, located in the “Adjustments and Correction Constants” chapter of the *HP 8753D Option 011 Service Guide*. Repeat this performance test.
- 4 Consult the *HP 8753D Option 011 Service Guide* for further troubleshooting information.

8. Receiver Phase Frequency Response

8. Receiver Phase Frequency Response

Perform this test to determine the phase tracking frequency response for each pair of inputs (A/R, B/R and A/B) in the swept sweep mode.

Required Equipment

- 3-way Power Splitter, 50Ω HP 11850C
- Attenuator, 10 dB HP 8491A Option 010
- RF cable set, 50Ω, Type-N HP 11851B
- RF cable, 50Ω, Type-N HP P/N 8120-4781
- Adapter, Type-N (m) to Type-N (m) HP P/N 1250-1475

Procedure

- 1 Connect the equipment as shown in Figure 6-12.

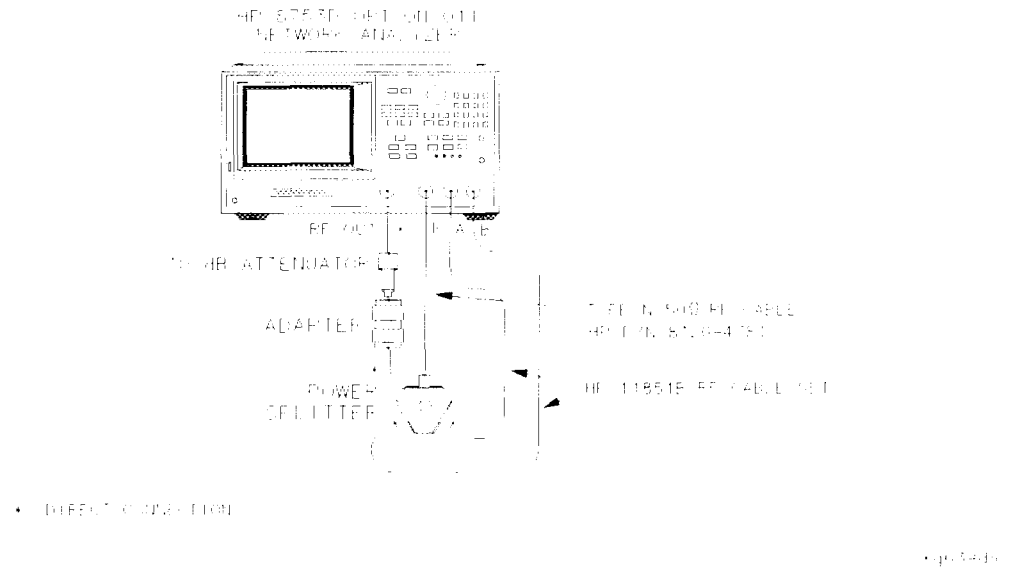

Figure 6-12. Phase Frequency Response Test Setup

8. Receiver Phase Frequency Response

Phase Frequency Response from 300 kHz to 3 GHz

- 2** Press PRESET, MENU, *POWER*, 10, x1.
- 3** *Only for Analyzers with Option 006:* Press STOP, 3, G/n.
- 4** Press FORMAT, *PHASE*, MARKER FCTN, *MARKER MODE MENU*, *STATS ON*.
- 5** Press SCALE REF, .6, x1, *ELECTRICAL DELAY*. Turn the analyzer front panel knob to vary the electrical delay until the trace is in the most linear horizontal position.
- 6** Press MENU, *TRIGGER MENU*, *SINGLE*. Write the p-p value, which appears on the analyzer display, on the “Performance Test Record.”
- 7** Press *CONTINUOUS*, MEAS, *INPUT PORTS*, B/R, FORMAT, *PHASE*.
- 8** Repeat Step 5 and Step 6.
- 9** Press *CONTINUOUS*, MEAS, *INPUT PORTS*, A/B, FORMAT, *PHASE*.
- 10** Repeat Step 5 and Step 6.

Phase Frequency Response from 3 GHz to 6 GHz

- 11** Press START, 3, G/n, STOP, 6, G/n, *CONTINUOUS*.
- 12** Press SCALE REF, *ELECTRICAL DELAY*. Turn the analyzer front panel knob to vary the electrical delay until the trace is in the most linear horizontal position.
- 13** Press MENU, *TRIGGER MENU*, *SINGLE*. Write the p-p value, which appears on the analyzer display, on the “Performance Test Record.”
- 14** Press *CONTINUOUS*, MEAS, *INPUT PORTS*, A/R.
- 15** Repeat Step 12 and Step 13.
- 16** Press *CONTINUOUS*, MEAS, *INPUT PORTS*, B/R.
- 17** Repeat Step 12 and Step 13.

**In Case of
Difficulty**

WARNING

These servicing instructions are for use by qualified personnel only. To avoid electrical shock, do not perform any servicing unless you are qualified to do so.

WARNING

The opening of covers or removal of parts is likely to expose dangerous voltages. Disconnect the instrument from all voltage sources while it is being opened.

WARNING

The power cord is connected to internal capacitors that may remain live for five seconds after disconnecting the plug from its power supply.

- 1** Verify that the RF cables are in good condition. Move the RF cables to different ports on the power splitter and remeasure the receiver input(s) that failed.
- 2** Perform the “Sampler Magnitude and Phase Correction Constants (Test 53)” procedure in the “Adjustments and Correction Constants” chapter of the *HP 8753D Option 011 Service Guide*.
- 3** Refer to the *HP 8753D Option 011 Service Guide* for further troubleshooting information.

9. Receiver Input Crosstalk

9. Receiver Input Crosstalk

Perform this test to verify the signal leakage interference between the input and output test ports, with one port driven and the other one terminated.

Required Equipment

2-way Power Splitter (2), 50 Ω HP 11667A Option 001
 Termination (3), 50 Ω HP 908A
 Attenuator, 20 dB HP 8491A Option 020
 RF cable set, 50 Ω , Type-N HP 11851B

Procedure***R into A Crosstalk from 300 kHz to 1 GHz***

- 1 Connect the equipment as shown in Figure 6-13.

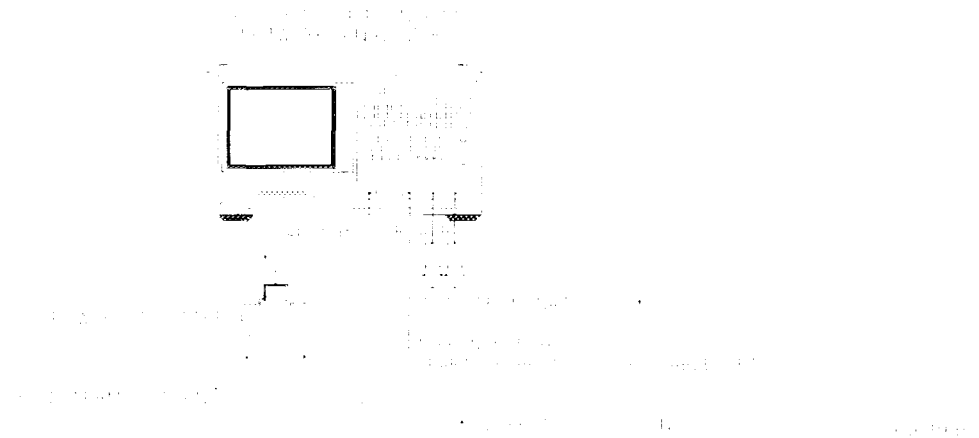

Figure 6-13. R into A and R into B Crosstalk Test Setup

- 2 Press PRESET, MENU, POWER, 6, x1, AVG, AVERAGING FACTOR, 5, x1, AVERAGING ON, IF BW, 10, x1.
- 3 Press SCALE REF, 25, x1 to get a better scaling of the data trace.
- 4 Press MARKER FCTN, MARKER MODE MENU, MKR SEARCH ON, TRACKING ON, SEARCH:MAX.
- 5 Press STOP, 1, G/n, MENU, TRIGGER MENU, NUMBER of GROUPS, 5, x1.
- 6 When the analyzer finishes the number of sweeps, write the marker value, which appears on the analyzer display, on the “Performance Test Record.”

9. Receiver Input Crosstalk***R into A Crosstalk from 1 GHz to 3 GHz***

- 7 Press START, 1, G/n, STOP, 3, G/n, *NUMBER of GROUPS*, 5, x1.
- 8 When the analyzer finishes the number of sweeps, write the marker value, which appears on the analyzer display, on the “Performance Test Record.”

(Only for Option 006 Analyzers) R into A Crosstalk from 3 GHz to 4.5 GHz

- 9 Press START, 3, G/n, STOP, 4.5, G/n, *NUMBER of GROUPS*, 5, x1.
- 10 When the analyzer finishes the number of sweeps, write the marker value, which appears on the analyzer display, on the “Performance Test Record.”

(Only for Option 006 Analyzers) R into A Crosstalk from 4.5 GHz to 6 GHz

- 11 Press START, 4.5, G/n, STOP, 6, G/n, *NUMBER of GROUPS*, 5, x1.
- 12 When the analyzer finishes the number of sweeps, write the marker value, which appears on the analyzer display, on the “Performance Test Record.”

R into B Crosstalk from 300 kHz to 1 GHz

- 13 Press START, 300, k/m, STOP, 1, G/n.
- 14 Press MEAS, *INPUT PORTS*, B/R, MENU, *TRIGGER MENU*, *NUMBER of GROUPS*, 5, x1.
- 15 When the analyzer finishes the number of sweeps, write the marker value, which appears on the analyzer display, on the “Performance Test Record.”

R into B Crosstalk from 1 GHz to 3 GHz

- 16 Press START, 1, G/n, STOP, 3, G/n, MENU, *TRIGGER MENU*, *NUMBER of GROUPS*, 5, x1.
- 17 When the analyzer finishes the number of sweeps, write the marker value, which appears on the analyzer display, on the “Performance Test Record.”

(Only for Option 006 Analyzers) R into B Crosstalk from 3 GHz to 4.5 GHz

- 18 Press START, 3, G/n, STOP, 4.5, G/n, MENU, *TRIGGER MENU*, *NUMBER of GROUPS*, 5, x1.
- 19 When the analyzer finishes the number of sweeps, write the marker value, which appears on the analyzer display, on the “Performance Test Record.”

9. Receiver Input Crosstalk

(Only for Option 006 Analyzers) R into B Crosstalk from 4.5 GHz to 6 GHz

- 20 Press START, 4.5, G/n, STOP, 6, G/n, MENU, *TRIGGER MENU*, *NUMBER of GROUPS*, 5, x1.
- 21 When the analyzer finishes the number of sweeps, write the marker value, which appears on the analyzer display, on the “Performance Test Record.”

B into A Crosstalk from 300 kHz to 1 GHz

- 22 Connect the equipment as shown in Figure 6-14.



Figure 6-14. B into A Receiver Input Crosstalk Test Setup

- 23 Press START, 300, k/m, STOP, 1, G/n.
- 24 Press MEAS, *INPUT PORTS*, A/B, MENU, *TRIGGER MENU*, *NUMBER of GROUPS*, 5, x1.
- 25 When the analyzer finishes the number of sweeps, write the marker value, which appears on the analyzer display, on the “Performance Test Record.”

B into A Crosstalk from 1 GHz to 3 GHz

- 26 Press START, 1, G/n, STOP, 3, G/n, MENU, *TRIGGER MENU*, *NUMBER of GROUPS*, 5, x1.
- 27 When the analyzer finishes the number of sweeps, write the marker value, which appears on the analyzer display, on the “Performance Test Record.”

(Only for Option 006 Analyzers) B into A Crosstalk from 3 GHz to 4.5 GHz

- 28** Press START, 3, G/n, STOP, 4.5, G/n, TRIGGER MENU, NUMBER of GROUPS, 5, x1.
- 29** When the analyzer finishes the number of sweeps, write the marker value, which appears on the analyzer display, on the “Performance Test Record.”

(Only for Option 006 Analyzers) B into A Crosstalk from 4.5 GHz to 6 GHz

- 30** Press START, 4.5, G/n, STOP, 6, G/n, TRIGGER MENU, NUMBER of GROUPS, 5, x1.
- 31** When the analyzer finishes the number of sweeps, write the marker value, which appears on the analyzer display, on the “Performance Test Record.”

A into B Crosstalk from 300 kHz to 1 GHz

- 32** Connect the equipment as shown in Figure 6-15.

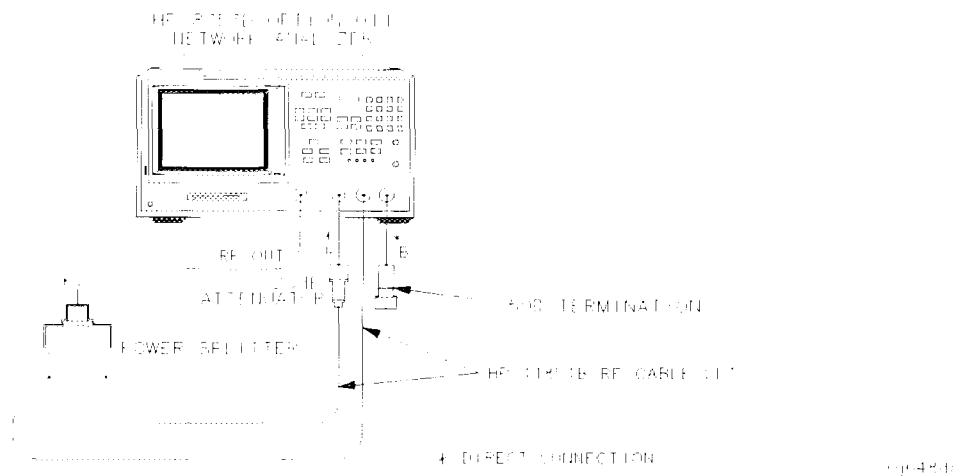

Figure 6-15. A into B Receiver Input Crosstalk Test Setup

- 33** Press START, 300, k/m, STOP, 1, G/n.
- 34** Press MEAS, INPUT PORTS, A/R, AVG, AVERAGING OFF, MENU, TRIGGER MENU, SINGLE.
- 35** At the end of the sweep, press DISPLAY, DATA→MEMORY, DATA/MEM, MEAS, INPUT PORTS, B/R.

9. Receiver Input Crosstalk

- 36 Press AVG, AVERAGING FACTOR, 5, x1, AVERAGING ON, MENU, TRIGGER MENU, NUMBER of GROUPS, 5, x1.
- 37 When the analyzer finishes the number of sweeps, write the marker value, which appears on the analyzer display, on the “Performance Test Record.”

A into B Crosstalk from 1 GHz to 3 GHz

- 38 Press START, 1, G/n, STOP, 3, G/n.
- 39 Press MEAS, INPUT PORTS, A/R, AVG, AVERAGING OFF, MENU, TRIGGER MENU, SINGLE.
- 40 At the end of the sweep, press DISPLAY, DATA → MEMORY, DATA/MEM, MEAS, INPUT PORTS, B/R.
- 41 Press AVG, AVERAGING FACTOR, 5, x1, AVERAGING ON, MENU, TRIGGER MENU, NUMBER of GROUPS, 5, x1.
- 42 When the analyzer finishes the number of sweeps, write the marker value, which appears on the analyzer display, on the “Performance Test Record.”

(Only for Option 006 Analyzers) A into B Crosstalk from 3 GHz to 4.5 GHz

- 43 Press START, 3, G/n, STOP, 4.5, G/n.
- 44 Press MEAS, INPUT PORTS, A/R, AVG, AVERAGING OFF, MENU, TRIGGER MENU, SINGLE.
- 45 At the end of the sweep, press DISPLAY, DATA → MEMORY, DATA/MEM, MEAS, INPUT PORTS, B/R.
- 46 Press AVG, AVERAGING FACTOR, 5, x1, AVERAGING ON, MENU, TRIGGER MENU, NUMBER of GROUPS, 5, x1.
- 47 When the analyzer finishes the number of sweeps, write the marker value, which appears on the analyzer display, on the “Performance Test Record.”

(Only for Option 006 Analyzers) A into B Crosstalk from 4.5 GHz to 6 GHz

- 48 Press START, 4.5, G/n, STOP, 6, G/n.
- 49 Press MEAS, INPUT PORTS, A/R, AVG, AVERAGING OFF, MENU, TRIGGER MENU, SINGLE.
- 50 At the end of the sweep, press DISPLAY, DATA → MEMORY, DATA/MEM, MEAS, INPUT PORTS, B/R.
- 51 Press AVG, AVERAGING FACTOR, 5, x1, AVERAGING ON, MENU, TRIGGER MENU, NUMBER of GROUPS, 5, x1.

- 52 When the analyzer finishes the number of sweeps, write the marker value, which appears on the analyzer display, on the “Performance Test Record.”

**In Case of
Difficulty**

WARNING

These servicing instructions are for use by qualified personnel only. To avoid electrical shock, do not perform any servicing unless you are qualified to do so.

WARNING

The opening of covers or removal of parts is likely to expose dangerous voltages. Disconnect the instrument from all voltage sources while it is being opened.

WARNING

The power cord is connected to internal capacitors that may remain live for five seconds after disconnecting the plug from its power supply.

- 1 Check for loose external RF cables. Inspect all cables for signs of damage, wear, or faulty shielding.
- 2 Remove the analyzer top cover. Tighten any loose SMA connector nuts on the four semi-rigid cables located between the A4/5/6 sampler/mixer assemblies.
- 3 Tighten any loose screws on the A4/5/6 sampler/mixer and the A7 pulse generator assembly covers.
- 4 Examine the shielding clips on the A5 sampler/mixer and the A7 pulse generator assemblies. In addition, inspect the shielding posts on the A10 digital IF board assembly.
- 5 Verify that the analyzer front panel Type-N connectors are tight. Check for connector damage.
- 6 Refer to the *HP 8753D Option 011 Service Guide* for additional troubleshooting information.

10. Receiver Trace Noise

10. Receiver Trace Noise

Perform this test to verify the receiver trace noise on a CW signal in ratio mode.

Required Equipment

3-way Power Splitter, 50Ω	HP 11850C
Attenuator, 10 dB	HP 8491A Option 010
RF cable set, 50Ω, Type-N	HP 11851B
RF cable, 50Ω, Type-N	HP P/N 8120-4781
Adapter, Type-N (m) to Type-N (m)	HP P/N 1250-1475

Procedure

- 1 Connect the equipment as shown in Figure 6-16.

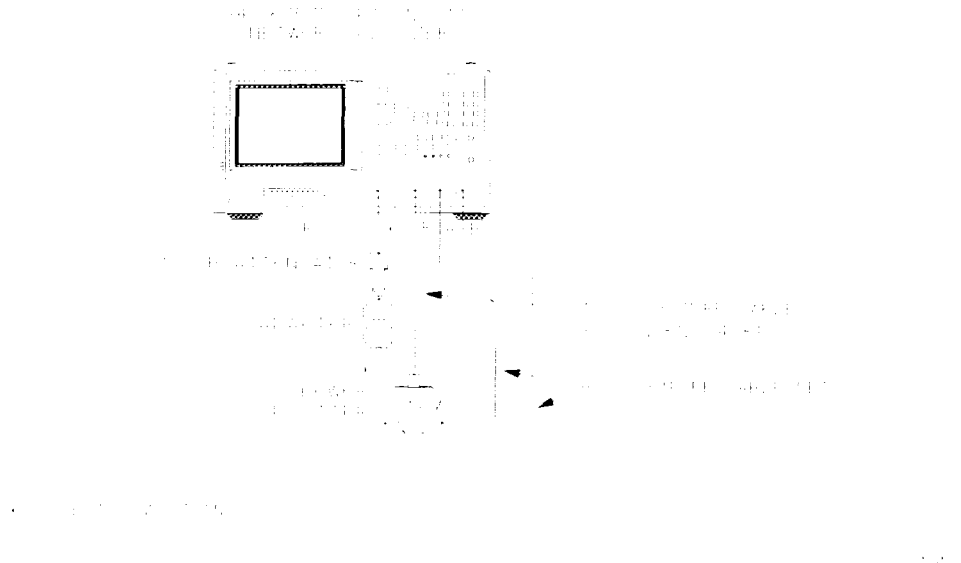

Figure 6-16. Receiver Trace Noise Test Setup

- 2 Press PRESET, MENU, POWER, 10, x1, MENU, NUMBER of POINTS, 1601, x1.
- 3 Press CWFREQ, 3, G/n (or 6, G/n for analyzers with Option 006).

- 4 Press **MARKER FCTN**, *MARKER MODE MENU*, *STATS ON* to activate the instrument's statistic feature.
- 5 Write the s.dev (standard deviation) value, which appears on the analyzer display, on the "Performance Test Record."
- 6 Press **MEAS**, *INPUT PORTS*, *B/R*. Write the s.dev (standard deviation) value on the "Performance Test Record."
- 7 Press *A/B*. Write the s.dev (standard deviation) value on the "Performance Test Record."
- 8 Press **FORMAT**, *PHASE*. Write the s.dev (standard deviation) value on the "Performance Test Record."
- 9 Press **MEAS**, *INPUT PORTS*, *B/R*, **FORMAT**, *PHASE*. Write the s.dev (standard deviation) value on the "Performance Test Record."
- 10 Press **MEAS**, *INPUT PORTS*, *A/R*, **FORMAT**, *PHASE*. Write the s.dev (standard deviation) value on the "Performance Test Record."

In Case of Difficulty

WARNING

These servicing instructions are for use by qualified personnel only. To avoid electrical shock, do not perform any servicing unless you are qualified to do so.

WARNING

The opening of covers or removal of parts is likely to expose dangerous voltages. Disconnect the instrument from all voltage sources while it is being opened.

WARNING

The power cord is connected to internal capacitors that may remain live for five seconds after disconnecting the plug from its power supply.

- 1 Verify that the 50 Ω Type-N RF cables are in good condition. If possible, try to rerun this test with another set of RF cables.
- 2 Suspect the A10 Digital IF board assembly if the analyzer still fails the test.

11. Receiver Input Impedance

11. Receiver Input Impedance

Perform this test to verify the return loss of each of the analyzer's receiver inputs.

Required Equipment

Test set, 50 Ω	HP 85044A/85046A/85047A
2-way Power Splitter, 50 Ω	HP 11667A Option 001
Attenuator, 10 dB	HP 8491A Option 010
Termination, 50 Ω	HP 908A
Calibration kit, 50 Ω , Type-N	HP 85032B
Adapter, APC-7 to Type-N (m)	HP 11525A
RF cable set, 50 Ω , Type-N	HP 11851B
RF cable, 50 Ω , 7 mm	Part of 11857D

Procedure

- 1 Connect the equipment as shown in Figure 6-17.
 - If you are using the HP 85044A test set, set the attenuation to 0 dB.
 - If you are using the HP 85046A or 85047A test set, connect the test set interface cable to the analyzer and use the test set port 1.



Figure 6-17. Receiver B Input Impedance Test Setup

- 2** Press PRESET, MENU, NUMBER of POINTS, 1601, x1.
- 3** Press CAL, CAL KIT & STDS, SELECT CAL KIT, N 50 Ω, RETURN, RETURN, CALIBRATE MENU, S11 1-PORT.
- 4** Connect an open to the test port cable adapter, by pressing FORWARD: OPENS, OPEN (M), DONE: OPENS.
- 5** Connect a short to the test port cable adapter, by pressing FORWARD: SHORTS, SHORT (M), DONE: SHORTS.
- 6** Connect a 50Ω termination to the adapted test port cable, by pressing FORWARD: LOAD, DONE 1-PORT CAL.
- 7** Remove the 50Ω termination from the test port cable adapter. Connect the adapted test port cable to the analyzer Input B. Press SCALE REF, AUTO SCALE.
- 8** Press MARKER, 300, k/m to set the marker 1 to 300 kHz. Write the marker value, which appears on the analyzer display, on the “Performance Test Record.”
- 9** Press MARKER 1, 2, M/μ, MARKER 2, 1.3, G/n to set marker 1 and marker 2 to 2 MHz and 1.3 GHz respectively.
- 10** Use the analyzer front panel knob to move marker 2 to the peak value between 2 MHz and 1.3 GHz. Write the marker 2 reading on the “Performance Test Record.”

11. Receiver Input Impedance

NOTE

The marker 2 reading represents the worst case return loss of the receiver input in the frequency range of 2 MHz to 1.3 GHz.

- 11 Press *MARKER 1*, 1.3, G/n, *MARKER 2*, 3, G/n to set marker 1 and marker 2 to 1.3 GHz and 3 GHz respectively.
- 12 Use the analyzer front panel knob to move marker 2 to the peak value between 1.3 GHz and 3 GHz. Write the marker 2 reading on the “Performance Test Record.”
- 13 Connect the equipment as shown in Figure 6-18.

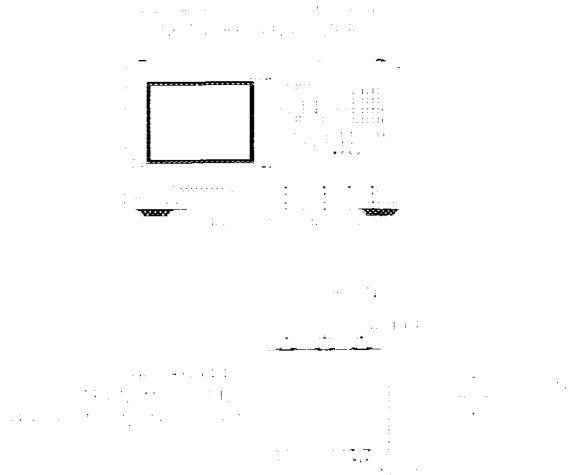

Figure 6-18. Receiver A Input Impedance Test Setup

- 14 Press *PRESET*, *MEAS*, *INPUT PORTS*, *B/R*, *MENU*, *NUMBER of POINTS*, 1601, x1.
- 15 Press *CAL*, *CALIBRATE MENU*, *S11 1-PORT*. Repeat Step 4 through Step 12 for the analyzer receiver input A return loss.

16 Connect the equipment as shown in Figure 6-19.

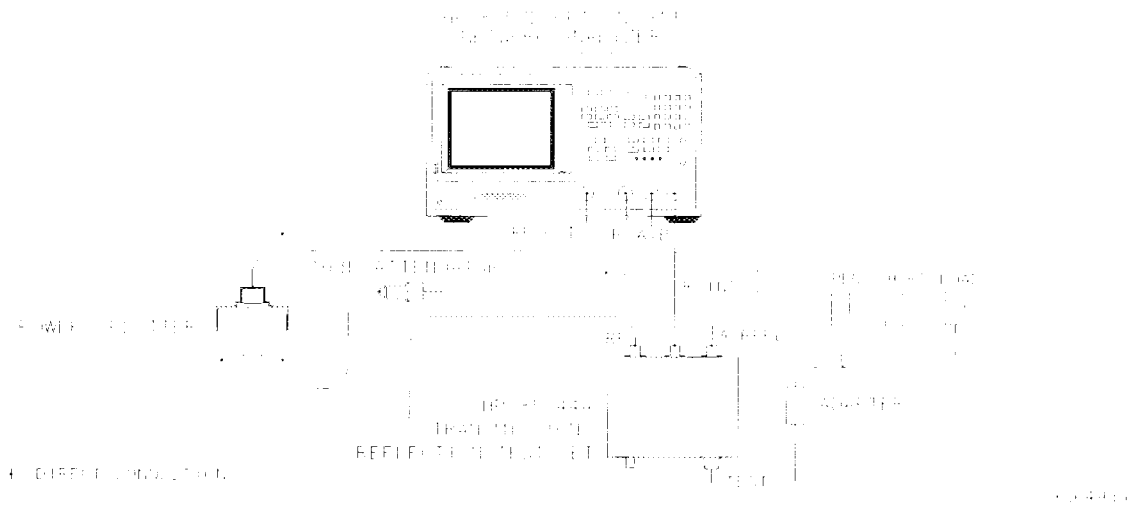

Figure 6-19. Receiver R Input Impedance Test Calibration Test Setup

- 17** Press PRESET, MEAS, *INPUT PORTS*, A/B, MENU, *NUMBER of POINTS*, 1601, x1.
- 18** Press CAL, *CALIBRATE MENU*, *S11 1-PORT*. Repeat Step 4 through Step 6 to perform a S11 1-port calibration.
- 19** Connect the equipment as shown in Figure 6-20.

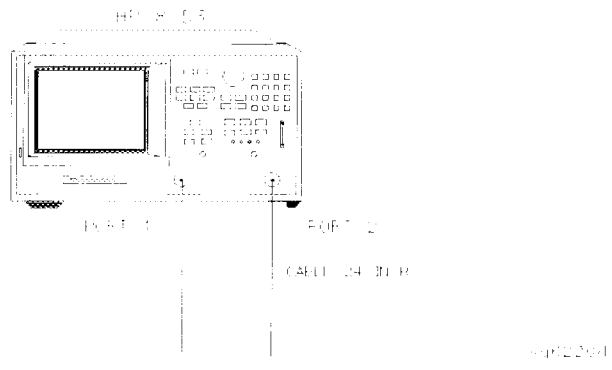

Figure 6-20. Receiver R Input Impedance Test Setup

11. Receiver Input Impedance

- 20** Repeat Step 7 through Step 12 to measure the receiver R input impedance.

**In Case of
Difficulty**

WARNING

These servicing instructions are for use by qualified personnel only. To avoid electrical shock, do not perform any servicing unless you are qualified to do so.

WARNING

The opening of covers or removal of parts is likely to expose dangerous voltages. Disconnect the instrument from all voltage sources while it is being opened.

WARNING

The power cord is connected to internal capacitors that may remain live for five seconds after disconnecting the plug from its power supply.

- 1** Check your test setup for damage or excessive wear of the input connectors.
- 2** Impedance mismatch may also be caused by the samplers, or the semi-rigid cables connecting the A4/A5/A6 sampler mixer assemblies to the analyzer front panel Type-N connectors. Check for damaged semi-rigid cables. If no damage is apparent at the input connectors, try interchanging the sampler assemblies. If the problem goes away, the sampler which you just swapped is defective. If the problem still exists, suspect the path from the Type-N connector input to the sampler assembly.
- 3** Refer to the *HP 8753D Option 011 Service Guide* for more troubleshooting information.

12. Receiver Magnitude Dynamic Accuracy

12. Receiver Magnitude Dynamic Accuracy

Perform this procedure to measure the magnitude dynamic accuracy for each input test port.

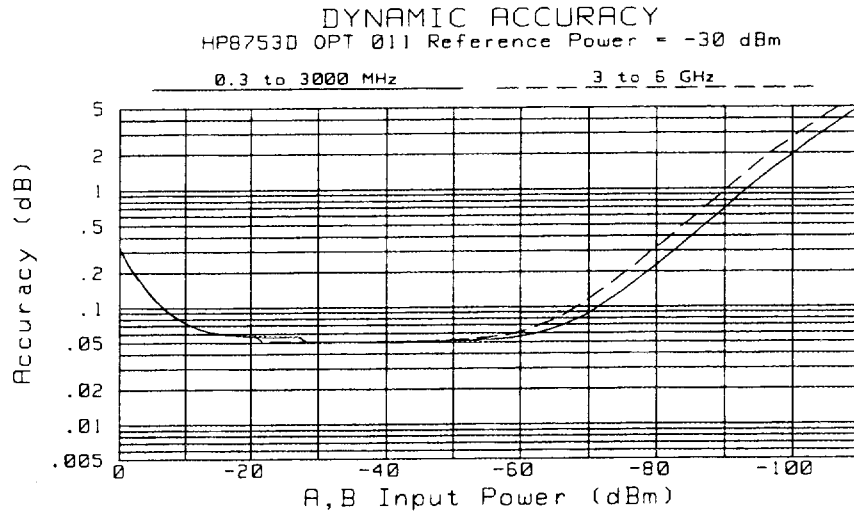

Figure 6-21. Receiver Magnitude Dynamic Accuracy

Required Equipment

Measuring Receiver	HP 8902A
Step Attenuator, 110 dB	HP 8496A
Attenuator, 10 dB	HP 8491A Option 010
Cable (4), 50Ω, Type-N, 24-inch	HP P/N 8120-4781
2-Way Power Splitter (2), 50Ω	HP 11667A
Adapter (2), Type-N (m) to Type-N (m)	HP P/N 1250-1475

Procedure

Channel A Magnitude Dynamic Accuracy

- 1** On the HP 8902A:
 - a** Press the blue shift key and INSTR PRESET, CLEAR.
 - b** Press the yellow shift key and TUNED RF LEVEL.
 - c** Press LOG/LIN to have the HP 8902A displayed linear readings (dBm).

12. Receiver Magnitude Dynamic Accuracy

- d** Press 32.1, SPCL.
- 2** Set the HP 8496A to 20 dB.
- 3** On the HP 8702D Option 011:
 - a** Press PRESET, MENU, *CW FREQ*, 30, M/ μ .
 - b** Press *NUMBER of POINTS*, 51, x1.
 - c** Press *AVG, IF BW*, 10, x1.
- 4** Connect the equipment as shown in Figure 6-22.

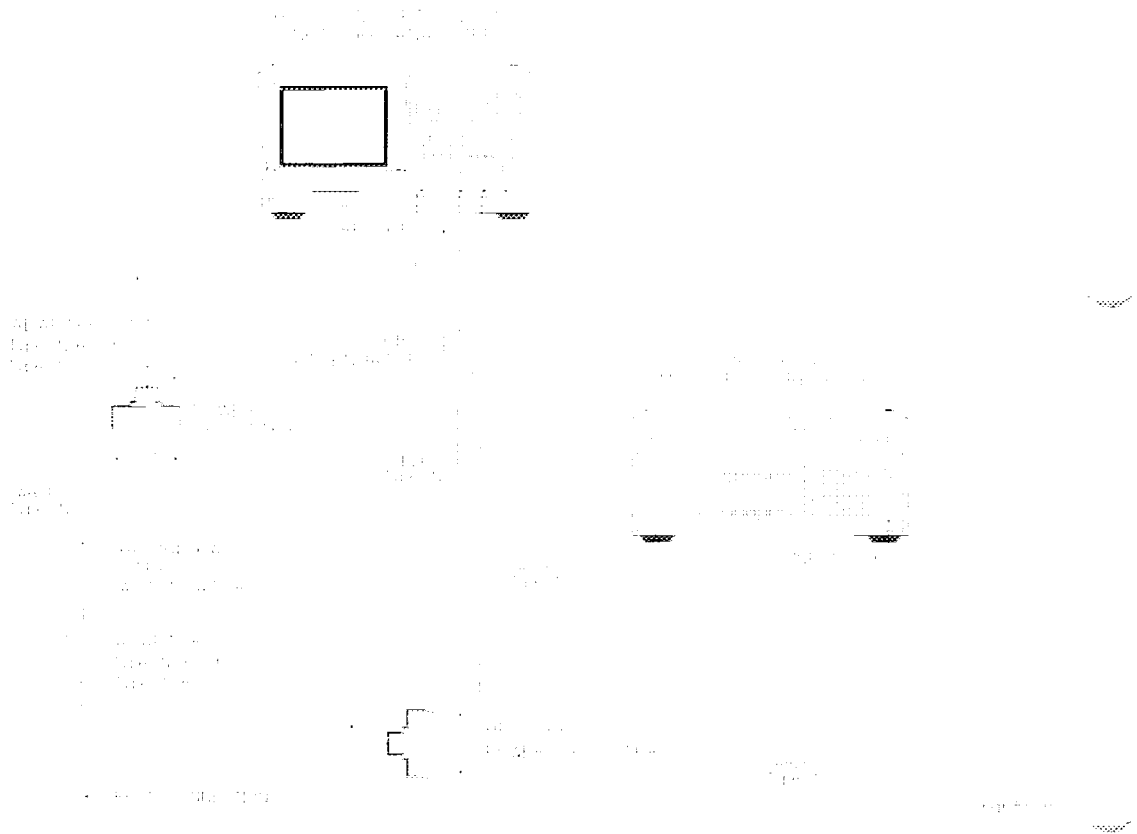

Figure 6-22. Channel A Magnitude Dynamic Accuracy Test Setup

12. Receiver Magnitude Dynamic Accuracy

- 5 On the HP 8702D Option 011:
 - a Press MEAS, *INPUT PORTS*, A, MENU, *POWER*.
 - b Using the analyzer front panel knob, adjust the test port power for a reading of -30.000 dBm₄ on the HP 8902A.
 - c Wait for the reading to stabilize.

NOTE

Ignore the UNCAL displayed on the HP 8902A. This indicates that you are making an approximate power level measurement. However, this is *not* a concern because you will be making a relative power measurement.

- 6 On the HP 8902A, press the blue shift key and SET REF.
- 7 On the HP 8702D Option 011:
 - a Press CAL, *CALIBRATE MENU*, *RESPONSE*, *THRU*.
 - b After the analyzer finishes the measurement, press *DONE: RESPONSE*.
 - c Press *SAVE/RECALL*, *SAVE STATE*.
 - d Press *MARKER FCTN*, *MARKER MODE MENU*, *STATS ON*.
- 8 Set the HP 8496A to 0 dB.
- 9 On the HP 8702D Option 011, press MENU, *TRIGGER MENU*, *SINGLE*.
- 10 Write the mean value (which appears on the analyzer's display) in the "Receiver Channel A" column of the "Performance Test Record."
- 11 Write the HP 8902A readout in the "8902A" column of the "Performance Test Record."
- 12 Calculate the difference between the "Receiver Channel A" and the "8902A".
- 13 Take the absolute value of the calculated difference, and enter the result in the "Magnitude Value" column of the "Performance Test Record."
- 14 Set the HP 8496A to the other attenuation settings listed in the "Performance Test Record."
- 15 On the HP 8702D Option 011, press *SINGLE*. Repeat Step 9 through Step 13.

12. Receiver Magnitude Dynamic Accuracy

NOTE

When the HP 8902A displays the "RECAL" annunciation, press CALIBRATE.

Channel B Magnitude Dynamic Accuracy

- 16** Set the HP 8496A to 20 dB.
- 17** On the HP 8702D Option 011, press *CONTINUOUS*, *MLAS*, *INPUT PORTS*, *B*.
- 18** Connect the equipment as shown in Figure 6-23.

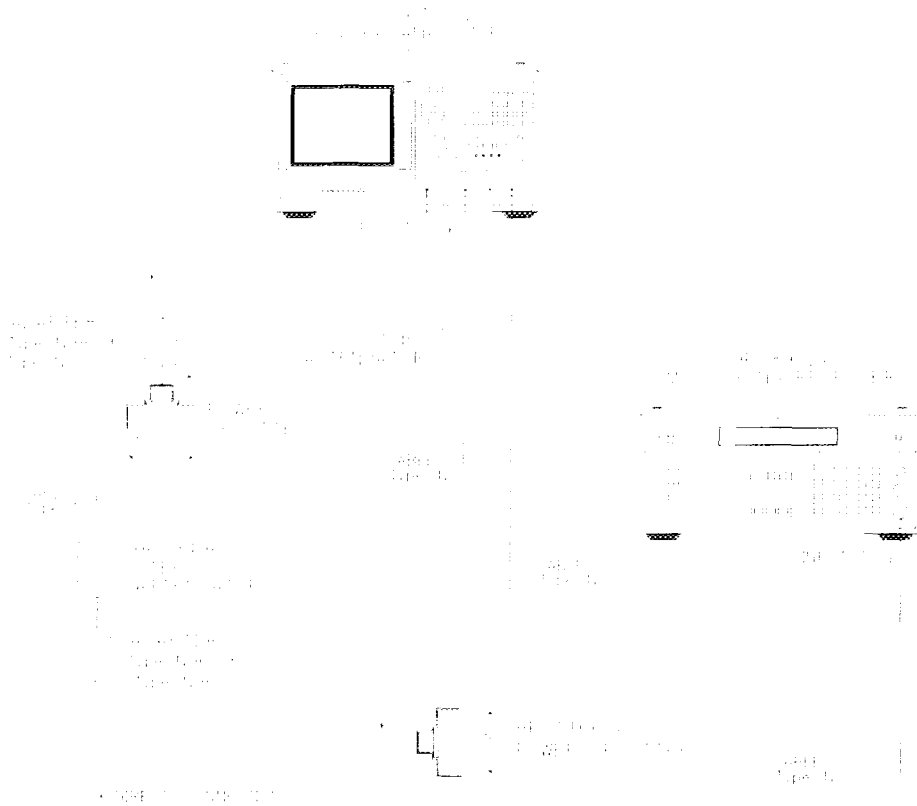

Figure 6-23. Channel B Magnitude Dynamic Accuracy Test Setup

12. Receiver Magnitude Dynamic Accuracy

- 19** On the HP 8702D Option 011:
 - a** Press MENU, *POWER*.
 - b** Using the analyzer front panel knob, adjust the test port power for a reading of 0.000 dB on the HP 8902A.
 - c** Wait for the reading to stabilize.
- 20** On the HP 8902A, press the blue shift key and SET REF.
- 21** On the HP 8702D Option 011:
 - a** Press CAL, *CALIBRATE MENU, RESPONSE, THRU*.
 - b** After the analyzer finishes the measurement, press *DONE: RESPONSE*.
 - c** Press SAVE/RECALL, *SAVE STATE*.
- 22** Set the HP 8496A to 0 dB.
- 23** On the HP 8702D Option 011, press MENU, *TRIGGER MENU, SINGLE*.
- 24** Write the mean value in the "Receiver Channel B" column of the "Performance Test Record."
- 25** Write the HP 8902A readout in the "8902A" column of the "Performance Test Record."
- 26** Calculate the difference between the "Receiver Channel B" and the "8902A".
- 27** Take the absolute value of the calculated difference and enter the result in the "Magnitude Value" column of the "Performance Test Record."
- 28** Set the HP 8496A to the other attenuation settings listed in the "Performance Test Record."
- 29** On the HP 8702D Option 011, press *SINGLE*. Repeat Step 23 through Step 27.

12. Receiver Magnitude Dynamic Accuracy

Channel R Magnitude Dynamic Accuracy

30 Connect the equipment as shown in Figure 6-24.

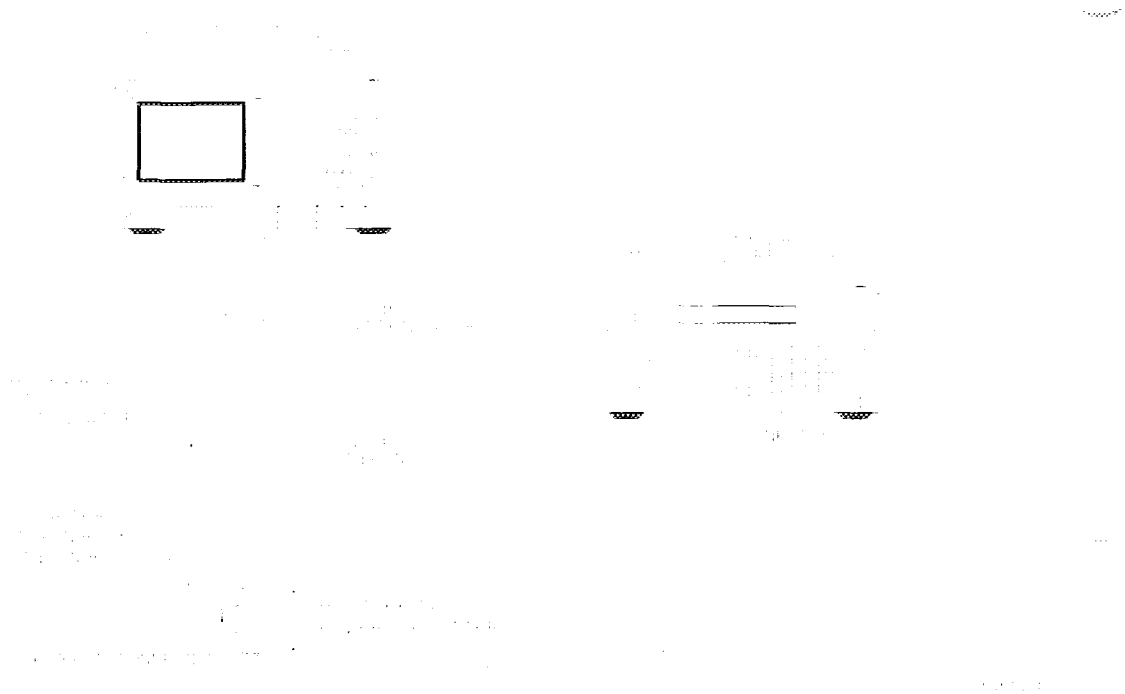

Figure 6-24. Channel R Magnitude Dynamic Accuracy Test Setup

- 31** Set the HP 8496A to 20 dB.
- 32** On the HP 8702D Option 011:
 - a** Press *CONTINUOUS*, *MEAS*, *INPUT PORTS*, *R*, *MENU*, *POWER*.
 - b** Using the analyzer front panel knob, adjust the test port power for a reading of 0.000 dB on the HP 8902A.
 - c** Wait for the reading to stabilize.
- 33** On the HP 8902A, press the blue shift key and *SET REF*.
- 34** On the HP 8702D Option 011:
 - a** Press *CAL*, *CALIBRATE MENU*, *RESPONSE*, *THRU*.

12. Receiver Magnitude Dynamic Accuracy

- b After the analyzer finishes the measurement, press *DONE: RESPONSE*.
 - c Press *SAVE/RECALL, SAVE STATE*.
- 35** Set the HP 8496A to 0 dB.
 - 36** On the HP 8702D Option 011, press *MENU, TRIGGER MENU, SINGLE*.
 - 37** Write the mean value in the "Receiver Channel R" column of the "Performance Test Record."
 - 38** Write the HP 8902A readout in the "8902A" column of the "Performance Test Record."
 - 39** Calculate the difference between the "Receiver Channel R" and the "8902A".
 - 40** Take the absolute value of the calculated difference and enter the result in the "Magnitude Value" column of the "Performance Test Record."
 - 41** Set the HP 8496A to the other attenuation settings listed in the "Performance Test Record."
 - 42** On the HP 8702D Option 011, press *SINGLE*. Repeat Step 36 through Step 41.

In Case of Difficulty**WARNING**

These servicing instructions are for use by qualified personnel only. To avoid electrical shock, do not perform any servicing unless you are qualified to do so.

WARNING

The opening of covers or removal of parts is likely to expose dangerous voltages. Disconnect the instrument from all voltage sources while it is being opened.

WARNING

The power cord is connected to internal capacitors that may remain live for five seconds after disconnecting the plug from its power supply.

- 1** If the analyzer fails the test at *all* power levels, be sure you followed the recommended attenuator settings as listed in the "Performance Test Record." Repeat this performance test.
- 2** If both test port measured values are out of specifications:
 - a** Recalibrate the HP 8902A, then press *CLEAR*.
 - b** Repeat this performance test.
 - c** Press *CALIBRATE* when either "UNCAL" or "RECAL" is shown on the measuring

12. Receiver Magnitude Dynamic Accuracy

receiver display.

- 3** If the analyzer fails either receiver channel 1 or receiver channel B dynamic accuracy at lower power levels:
 - a** Perform the "IF Amplifier Correction Constants" and "ADC Offset Correction Constants" procedures (located in the "Adjustments and Correction Constants" chapter of the *HP 8753D Option 011 Service Guide*).
 - b** Repeat this performance test.
 - c** If it still fails, replace the A10 Digital IF assembly.
 - d** Repeat the two adjustment procedures mentioned in this step and then repeat this performance test.

13. Receiver Phase Dynamic Accuracy

Perform this test to measure phase dynamic accuracy of each receiver channel.

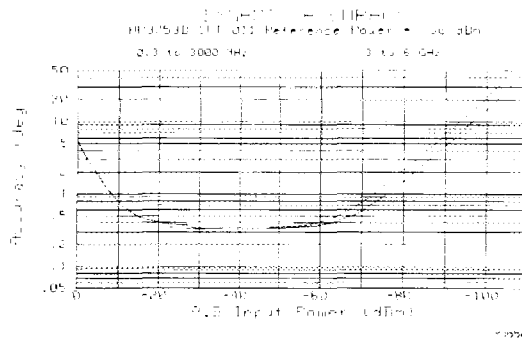

Figure 6-25. Dynamic Accuracy (Phase)

Procedure

Channel A Phase Dynamic Accuracy

- 1 Refer to the "Receiver Dynamic Accuracy-Magnitude" portion of the "Performance Test Record," for the values in the "Magnitude Value" column.
- 2 Copy the values in the "Magnitude Value" column to the "Magnitude Value" column of the "Receiver Dynamic Accuracy-Phase" portion of the "Performance Test Record."
- 3 For every receiver input power level, calculate "A" using the following formula:

$$A = 10 \left(\frac{\text{Calculated Value}}{20} \right)$$

- 4 Write the result in the "A" column of the "Performance Test Record."
- 5 For every receiver input power level, calculate "B" using the following formula:

$$B = I - A$$

- 6 Write the result in the "B" column of the "Performance Test Record."

13. Receiver Phase Dynamic Accuracy

- 7 For every receiver input power level, calculate the receiver phase dynamic accuracy using the following formula:

$$\text{Phase Dynamic Accuracy} = \text{SIN}^{-1}(B)$$

- 8 Write the value in the "Calculated Value" column of the "Performance Test Record."

Channel B Phase Dynamic Accuracy

- 9 Repeat Step 3 through Step 8.

Channel R Phase Dynamic Accuracy

- 10 Repeat Step 3 through Step 8.

14. Receiver Magnitude Compression

Perform this test to verify the compression/expansion magnitude levels of the analyzer's receiver samplers.

Required Equipment

Power Meter	HP 437B/438A
Power Sensor	HP 8482A
Attenuator, 3 dB	HP 8491A Option 003
Attenuator, 10 dB	HP 8491A Option 010
Attenuator, 20 dB	HP 8491A Option 020
Cable (2), 50 Ω , Type-N, 24-inch	HP P/N 8120-4781
2-way Power Splitter (2), 50 Ω	HP 11667A
Adapter, Type-N (m) to Type-N (m)	HP P/N 1250-1475

Additional Required Equipment for Analyzers with Option 006

Power Sensor	HP 8481A
------------------------	----------

Procedure

Channel A Magnitude Compression

- 1 Zero and calibrate the power meter.
- 2 Connect the equipment as shown in Figure 6-26.

14. Receiver Magnitude Compression

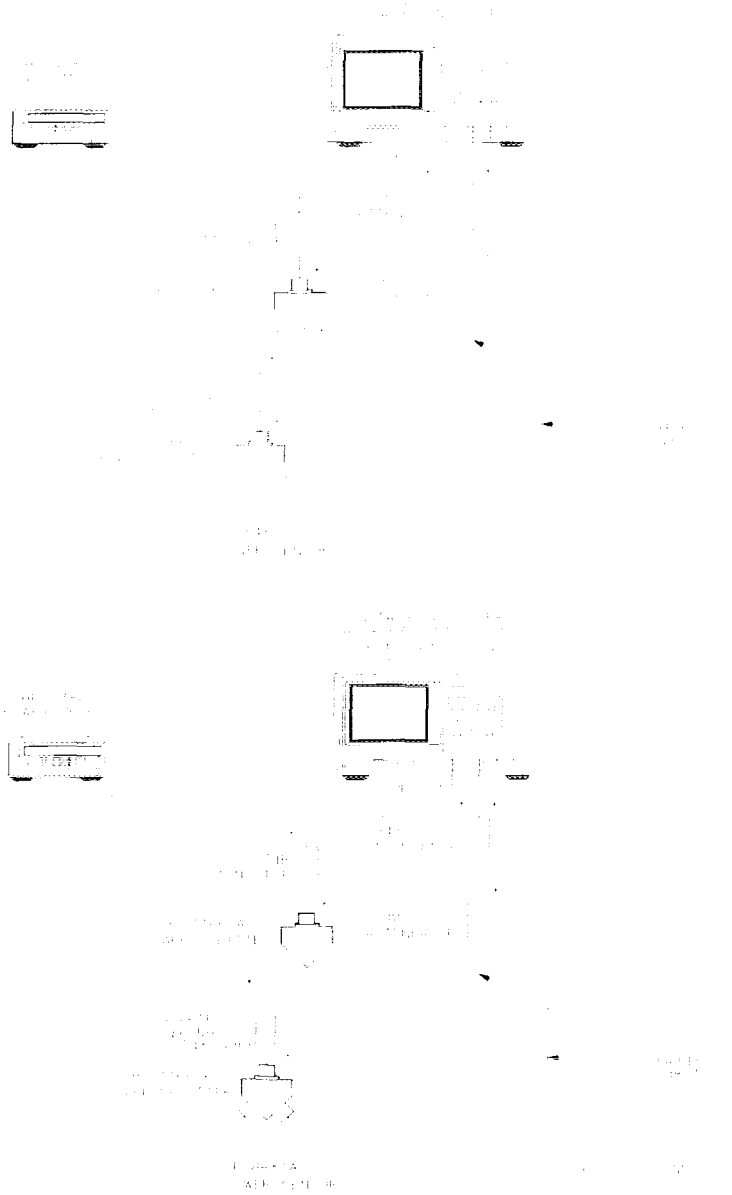

Figure 6-26. Channel A Magnitude Compression Test Setup

14. Receiver Magnitude Compression

- 3** Press PRESET, AVG, *IF BW*, 10, x1.
- 4** Press MENU, *CW FREQ*, 50, M/ μ . Set the calibration factor on the power meter for this CW frequency.
- 5** Press *POWER*, -4, x1. Use the analyzer's front panel knob to adjust the source power for a power meter reading of -20.00 dBm. Write the source power value, which appears on the analyzer's display, in the "Start Power" column of the "Performance Test Record".
- 6** Press 15, x1. Use the analyzer's front panel knob to adjust the source power for a power meter reading of 0.00 dBm. Write the source power value in the "Stop Power" column of the "Performance Test Record".
- 7** Press MENU, *SWEEP TYPE MENU*, *POWER SWEEP*, START. Use the analyzer's number keypad to enter the "Start Power" value as determined in Step 5.
- 8** Press STOP and enter the "Stop Power" value as determined in Step 6.
- 9** Press MENU, *TRIGGER MENU*, SINGLE.
- 10** At the end of the sweep, press SCALE REF, *AUTO SCALE*.
- 11** Press MARKER FCTN, *MARKER MODE MENU*, MKR SEARCH, SEARCH: MAX.
- 12** Press MARKER, MARKER 2, MARKER FCTN, *MARKER MODE MENU*, MKR SEARCH, SEARCH: MIN.
- 13** Press MARKER, *Δ MODE MENU*, *Δ REF= 1*.
- 14** Write the absolute value of the marker 2 reading in the "Measured Value" column of the "Performance Test Record."
- 15** Press MENU, *CW FREQ*, 1, G/n. Set the calibration factor on the power meter for this CW frequency.
- 16** Press *TRIGGER MENU*, CONTINUOUS, MENU, *SWEEP TIME MENU*, CW TIME.
- 17** Press MENU, *POWER*. Use the analyzer's front panel knob to adjust the source power for a power meter reading of -20.00 dBm. Write the source power value, which appears on the analyzer's display, in the "Start Power" column of the "Performance Test Record".
- 18** Press 15, x1. Use the analyzer's front panel knob to adjust the source power for a power meter reading of 0.00 dBm. Write the source power value, which appears on the analyzer's display, in the "Stop Power" column of the "Performance Test Record".
- 19** Press MENU, *SWEEP TYPE MENU*, *POWER SWEEP*, START. Use the analyzer's number keypad to enter the "Start Power" value as determined in Step 17.

14. Receiver Magnitude Compression

- 20** Press STOP and enter the “Stop Power” value as determined in Step 18.
- 21** Press MENU, *TRIGGER MENU, SINGLE*.
- 22** At the end of the sweep, press SCALE REF, *AUTO SCALE*.
- 23** Press MARKER, Δ *MODE MENU, Δ REF=1, MARKER FCTN, MARKER MODE MENU, MKR SEARCH, SEARCH: MAX*.
- 24** Press MARKER, *MARKER 2, MARKER FCTN, MARKER MODE MENU, MKR SEARCH, SEARCH: MIN*.
- 25** Write the absolute value of marker 2 in the “Measured Value” column on the “Performance Test Record.”
- 26** Repeat Step 15 through Step 25 for the other frequencies listed on the “Performance Test Record.”

Channel B Magnitude Compression

27 Connect the equipment as shown in Figure 6-27.

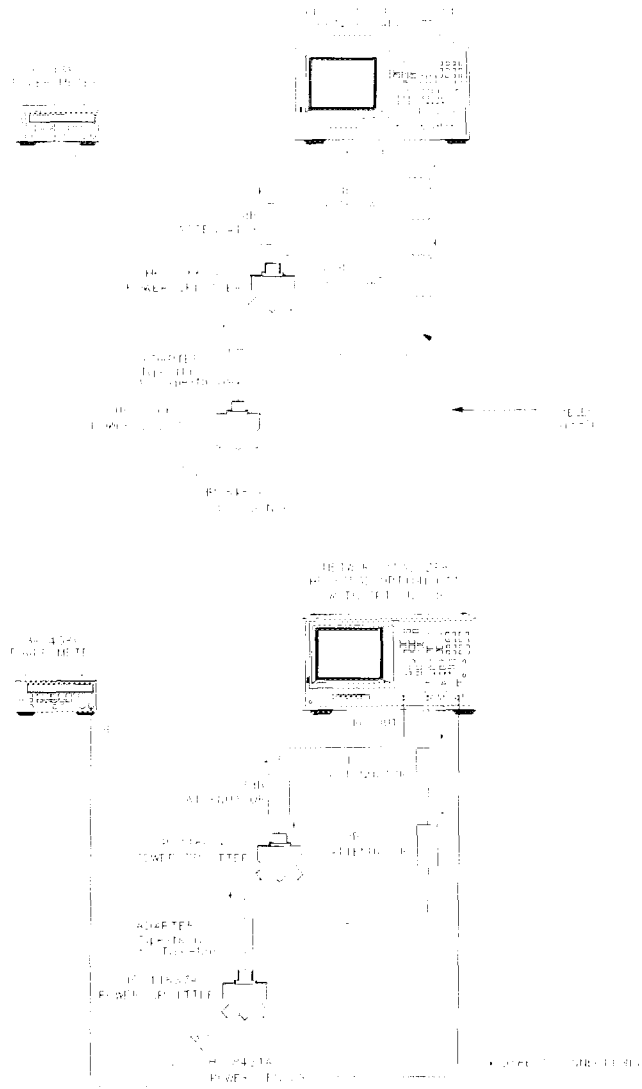

Figure 6-27. Channel B Magnitude Compression Test Setup

14. Receiver Magnitude Compression

- 28 Press MEAS, *INPUT PORTS*, *B/R*.
- 29 Repeat Step 26 for the CW frequencies listed in the “Performance Test Record”.

Channel R Magnitude Compression

30 Connect the equipment as shown in Figure 6-28.

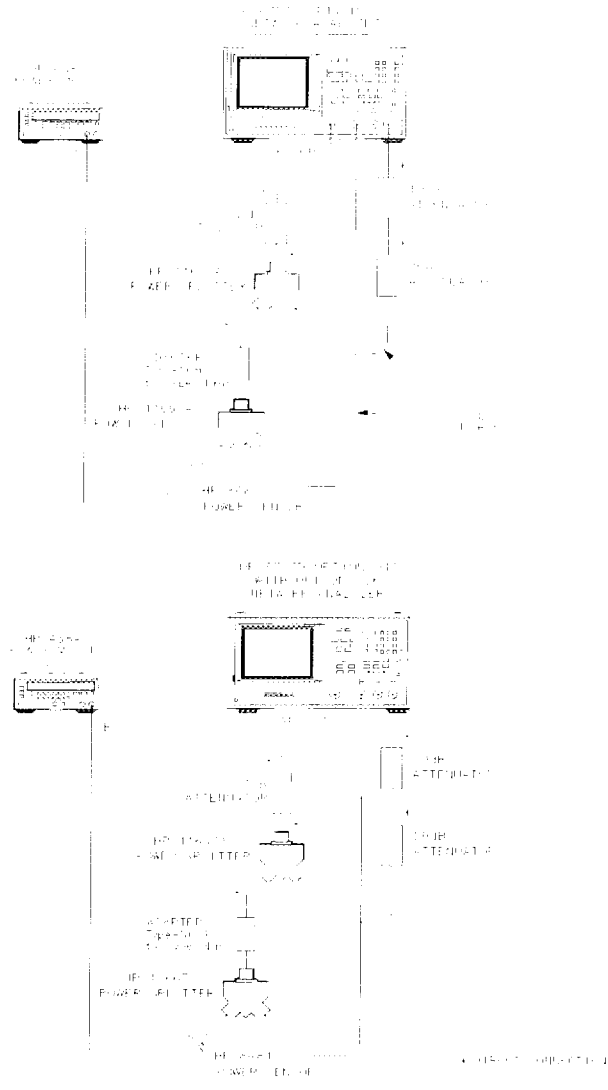

Figure 6-28. Channel R Magnitude Compression Test Setup

14. Receiver Magnitude Compression

- 31** Repeat Step 26 for the CW frequencies listed in the “Performance Test Record”.

In Case of Difficulty

WARNING

These servicing instructions are for use by qualified personnel only. To avoid electrical shock, do not perform any servicing unless you are qualified to do so.

WARNING

The opening of covers or removal of parts is likely to expose dangerous voltages. Disconnect the instrument from all voltage sources while it is being opened.

WARNING

The power cord is connected to internal capacitors that may remain live for five seconds after disconnecting the plug from its power supply.

- 1** If the analyzer fails the channel A compression test, suspect the A5 A sampler assembly. Repeat this test. Replace the sampler assembly if the problem still exists.
- 2** Suspect the A6 B sampler assembly if the analyzer fails the channel B compression test. Repeat this test. Exchange the sampler assembly if the failure still occurs.

15. Receiver Phase Compression

Perform this test to verify the compression/expansion phase relationships of the analyzer's receiver samplers.

Required Equipment

Power Meter	HP 437B/438A
Power Sensor	HP 8482A
Attenuator, 3 dB	HP 8491A Option 003
Attenuator, 10 dB	HP 8491A Option 010
Attenuator, 20 dB	HP 8491A Option 020
Cable (2), 50 Ω , Type-N, 24-inch	HP P/N 8120-4781
2-way Power Splitter (2), 50 Ω	HP 11667A
Adapter, Type-N (m) to Type-N (m)	HP P/N 1250-1475

Additional Required Equipment for Analyzers with Option 006

Power Sensor	HP 8481A
------------------------	----------

Procedure

Channel A Phase Compression

- 1 Zero and calibrate the power meter.

15. Receiver Phase Compression

- 2 Connect the equipment as shown in Figure 6-29.



Figure 6-29. Channel A Phase Compression Test Setup

- 3 Press PRESET, AVG, *IF BW*, 10, x1, FORMAT, *PHASE*.
- 4 Press MENU, *CWFREQ*, 50, M/ μ . Set the calibration factor on the power meter for this CW frequency.

15. Receiver Phase Compression

- 5 Press *POWER*, *-4*, *x1*.
- 6 Use the analyzer's front panel knob to adjust the source power for a power meter reading of -20.00 dBm. Write the source power value, which appears on the analyzer's display, in the "Start Power" column of the "Performance Test Record".
- 7 Press *15*, *x1*. Use the analyzer's front panel knob to adjust the source power for a power meter reading of 0.00 dBm. Write the source power value in the "Stop Power" column of the "Performance Test Record".
- 8 Press *MENU*, *SWEEP TYPE MENU*, *POWER SWEEP*, *START*. Use the analyzer's number keypad to enter the "Start Power" value as determined in Step 5.
- 9 Press *STOP* and enter the "Stop Power" value as determined in Step 7.
- 10 Press *MENU*, *TRIGGER MENU*, *SINGLE*.
- 11 At the end of the sweep, press *SCALE REF*, *AUTO SCALE*.
- 12 Press *MARKER FCTN*, *MARKER MODE MENU*, *MKR SEARCH*, *SEARCH: MAX*.
- 13 Press *MARKER*, *MARKER 2*, *MARKER FCTN*, *MARKER MODE MENU*, *MKR SEARCH*, *SEARCH: MIN*.
- 14 Press *MARKER*, *ΔMODE MENU*, *ΔREF= 1*.
- 15 Write the absolute value of the marker 2 reading in the "Measured Value" column of the "Performance Test Record."
- 16 Press *MENU*, *CW FREQ*, *1*, *G/n*. Set the calibration factor on the power meter for this CW frequency.
- 17 Press *TRIGGER MENU*, *CONTINUOUS*, *MENU*, *SWEEP TIME MENU*, *CW TIME*.
- 18 Press *MENU*, *POWER*. Use the analyzer's front panel knob to adjust the source power for a power meter reading of -20.00 dBm. Write the source power value, which appears on the analyzer's display, in the "Start Power" column of the "Performance Test Record".
- 19 Press *15*, *x1*. Use the analyzer's front panel knob to adjust the source power for a power meter reading of 0.00 dBm. Write the source power value, which appears on the analyzer's display, in the "Stop Power" column of the "Performance Test Record".
- 20 Press *MENU*, *SWEEP TYPE MENU*, *POWER SWEEP*, *START*. Use the analyzer's number keypad to enter the "Start Power" value as determined in Step 18.
- 21 Press *STOP* and enter the "Stop Power" value as determined in Step 19.
- 22 Press *MENU*, *TRIGGER MENU*, *SINGLE*.

15. Receiver Phase Compression

- 23** At the end of the sweep, press *SCALE REF*, *AUTO SCALE*.
- 24** Press *MARKER*, Δ *MODE MENU*, Δ *REF=1*, *MARKER FCTN*, *MARKER MODE MENU*, *MKR SEARCH*, *SEARCH: MAX*.
- 25** Press *MARKER*, *MARKER 2*, *MARKER FCTN*, *MARKER MODE MENU*, *MKR SEARCH*, *SEARCH: MIN*.
- 26** Write the absolute value of marker 2 in the "Measured Value" column on the "Performance Test Record."
- 27** Repeat Step 16 through Step 25 for the other frequencies listed on the "Performance Test Record."

Channel B Phase Compression

28 Connect the equipment as shown in Figure 6-30.

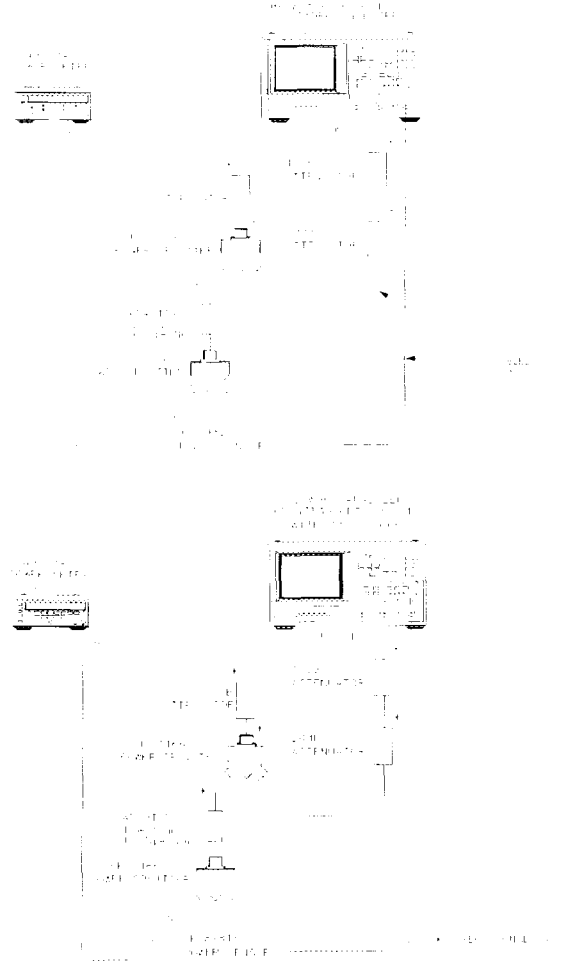

Figure 6-30. Channel B Phase Compression Test Setup

- 29** Press MEAS, *INPUT PORTS, B/R.*
- 30** Repeat Step 27 for the other CW frequencies listed in the “Performance Test Record.”

15. Receiver Phase Compression

Channel R Phase Compression

- 31** Connect the equipment as shown in Figure 6-31.

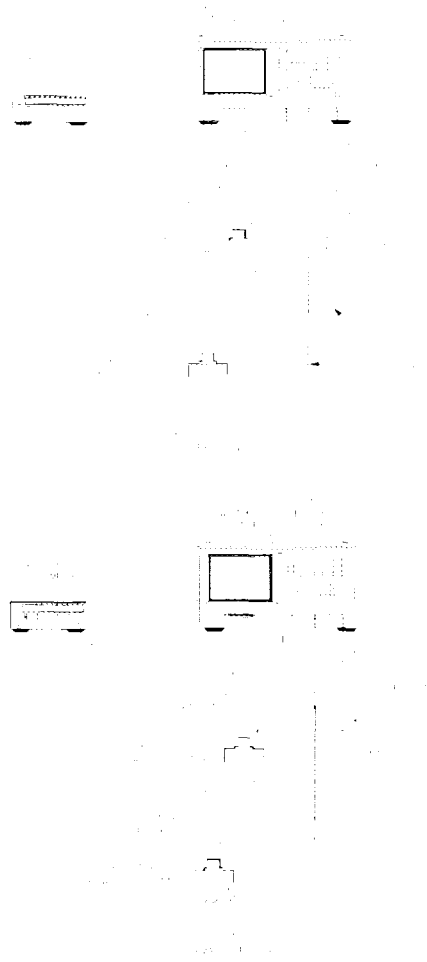

Figure 6-31. Channel R Phase Compression Test Setup

- 32** Repeat Step 27 for the other CW frequencies listed in the “Performance Test Record.”

**In Case of
Difficulty**

WARNING

These servicing instructions are for use by qualified personnel only. To avoid electrical shock, do not perform any servicing unless you are qualified to do so.

WARNING

The opening of covers or removal of parts is likely to expose dangerous voltages. Disconnect the instrument from all voltage sources while it is being opened.

WARNING

The power cord is connected to internal capacitors that may remain live for five seconds after disconnecting the plug from its power supply.

- 1** If the analyzer fails the channel A compression test, suspect the A5 A sample assembly. Repeat this test. Replace the sampler assembly if the problem still exists.
- 2** Suspect the A6 B sampler assembly if the analyzer fails the channel B compression test. Repeat this test. Exchange the sampler assembly if the failure still occurs.

16. Source and Receiver Harmonics (Option 002 Only)

16. Source and Receiver Harmonics (Option 002 Only)

Perform this test to determine the 2nd and 3rd harmonics of the source, receiver, and the source/receiver combination.

Required Equipment

2-way Power Splitter, 50 Ω	HP 11667A Option 001
Attenuator, 10 dB	HP 8491A Option 010
Attenuator, 30 dB	HP 8491A Option 030
RF cable set, 50 Ω , Type-N	HP 11851B

Procedure

Source Harmonics

- 1 Connect the equipment as shown in Figure 6-32.

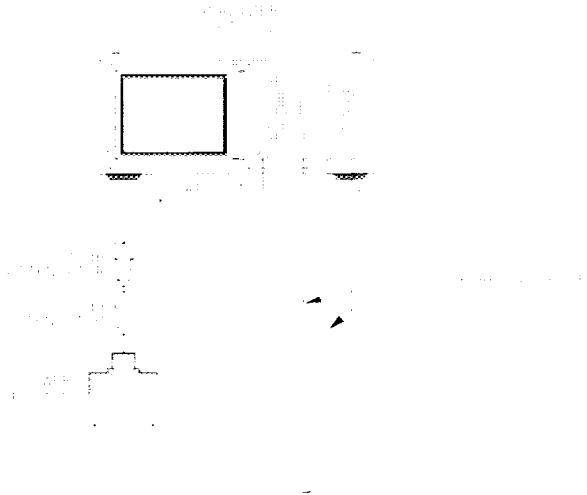

Figure 6-32. Source Harmonics Test Setup

- 2 Press PRESET, MENU, *POWER*, 20, x1.
- 3 Press START, 16, M/ μ , STOP, 1.5, G/n to set the frequency range for searching the source 2nd harmonic.

16. Source and Receiver Harmonics (Option 002 Only)

- 4** *Only for Analyzers with Option 006:* Press STOP, 3, G/n.
- 5** Press AVG, *IF BW*, 10, x1 to set the IF bandwidth to 10 Hz.
- 6** Press MEAS, *INPUT PORTS*, A.
- 7** After one sweep, press DISPLAY, *DATA→MEMORY*, *DATA/MEM* to normalize the trace and record the fundamental.
- 8** Press SYSTEM, *HARMONIC MEAS*, *HARMONIC SECOND* to prepare the analyzer for making a 2nd harmonic measurement.
- 9** After one sweep, press MARKER FCTN, *MARKER MODE MENU*, *MKR SEARCH*, *SEARCH MAX*.
- 10** Write the marker 1 value (which appears on the analyzer display) on the "Performance Test Record." This is the worst case source 2nd harmonic.
- 11** Press STOP, 1, G/n to change the stop frequency to 1 GHz.
- 12** *Only for Analyzers with Option 006:* Press STOP, 2, G/n.
- 13** Press SYSTEM, *HARMONIC MEAS*, *HARMONIC OFF*, DISPLAY.
- 14** After one sweep, press *DATA→MEMORY*, *DATA/MEM* to normalize the trace and record the fundamental.
- 15** Press SYSTEM, *HARMONIC MEAS*, *HARMONIC THIRD* to prepare the analyzer for making a 3rd harmonic measurement.
- 16** After one sweep, press MARKER FCTN, *MARKER MODE MENU*, *MKR SEARCH*, *SEARCH MAX*.
- 17** Write the marker 1 value on the "Performance Test Record."

16. Source and Receiver Harmonics (Option 002 Only)

Source and Receiver Harmonics

- 18** Connect the equipment as shown in Figure 6-33.

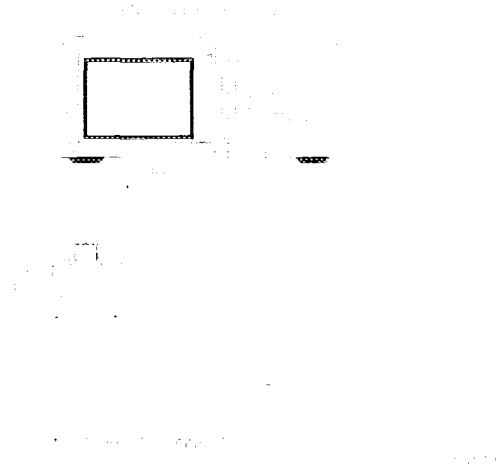

Figure 6-33. Source and Receiver Harmonics Test Setup

- 19** Press PRESET, MENU, *POWER*, 6, x1.
- 20** Press SYSTEM, *HARMONIC MEAS*, *HARMONIC OFF*, STOP, 1.5, G/n.
- 21** *Only for Analyzers with Option 006:* Press STOP, 3, G/n.
- 22** Repeat Step 6 through Step 9 to measure the source and receiver worst case 2nd harmonic for the receiver input A.
- 23** Repeat Step 11 through Step 16 to measure the source and receiver worst case 3rd harmonic for the receiver input A.
- 24** Move the receiver A input cable to receiver input B.
- 25** Press SYSTEM, *HARMONIC MEAS*, *HARMONIC OFF*, STOP, 1.5, G/n.
- 26** *Only for Analyzers with Option 006:* Press STOP, 3, G/n.
- 27** Repeat Step 6 through Step 9 to measure the source and receiver worst case 2nd harmonic for the receiver input B. Press MEAS, *INPUT PORTS*, B in Step 6.
- 28** Repeat Step 11 through Step 16 to measure the source and receiver worst case 3rd harmonic for the receiver input B.

Receiver Harmonics

- 29** Connect the equipment as shown in Figure 6-34.

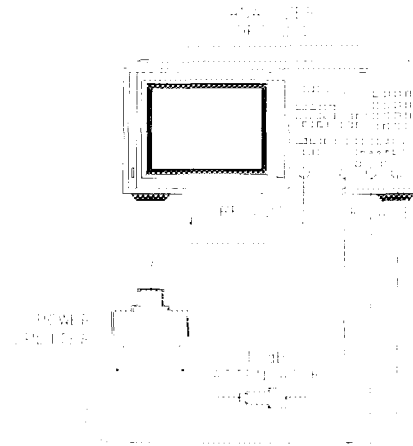

Figure 6-34. Receiver Harmonics Test Setup

Figure 6-34

Figure 6-34. Receiver Harmonics Test Setup

- 30** Press SYSTEM, *HARMONIC MEAS*, *HARMONIC OFF*, STOP, 1.5, G/n.
- 31** *Only for Analyzers with Option 006:* Press STOP, 3, G/n.
- 32** Repeat Step 6 through Step 9 to measure the receiver worst case 2nd harmonic for the receiver input B. Press MEAS, *INPUT PORTS*, B in Step 6.
- 33** Repeat Step 11 through Step 16 to measure the receiver worst case 3rd harmonic for the receiver input B.
- 34** Press SYSTEM, *HARMONIC MEAS*, *HARMONIC OFF*.
- 35** Repeat Step 6 through Step 9 to measure the receiver worst case 2nd harmonic for the receiver input A. Press MEAS, *INPUT PORTS*, A in Step 6.
- 36** Repeat Step 11 through Step 16 to measure the receiver worst case 3rd harmonic for the receiver input A.

16. Source and Receiver Harmonics (Option 002 Only)

**In Case of
Difficulty**

WARNING

These servicing instructions are for use by qualified personnel only. To avoid electrical shock, do not perform any servicing unless you are qualified to do so.

WARNING

The opening of covers or removal of parts is likely to expose dangerous voltages. Disconnect the instrument from all voltage sources while it is being opened.

WARNING

The power cord is connected to internal capacitors that may remain live for five seconds after disconnecting the plug from its power supply.

- 1** If source harmonics fail, replace the A3 source assembly.
- 2** If the A receiver harmonics fail, replace the A5 sampler/mixer assembly.
- 3** Replace the A6 sampler/mixer assembly if the B receiver harmonics fail.

17. Receiver Magnitude Frequency Response (Option 002 Only)

**17. Receiver Magnitude Frequency Response
(Option 002 Only)**

Perform this test to determine the receiver's ability to transfer information from RF to IF and how accurately that information is processed and displayed.

**Required
Equipment**

- External Source HP 83640A
- Power Meter HP 436A/437B/438A
- Power Sensor HP 8482A
- 3-way Power Splitter, 50Ω HP 11850C
- Attenuator, 10 dB HP 8491A Option 010
- RF cable set, 50Ω, Type-N HP 11851B
- Cable, BNC, 24-inch HP P/N 8120-1840
- Adapter, Type-N (m) to Type-N (m) HP P/N 1250-1475

Additional Equipment Required for Option 006

- Power Sensor HP 8481A

Procedure

Source Harmonics

- 1 Connect the equipment as shown in Figure 6-35.

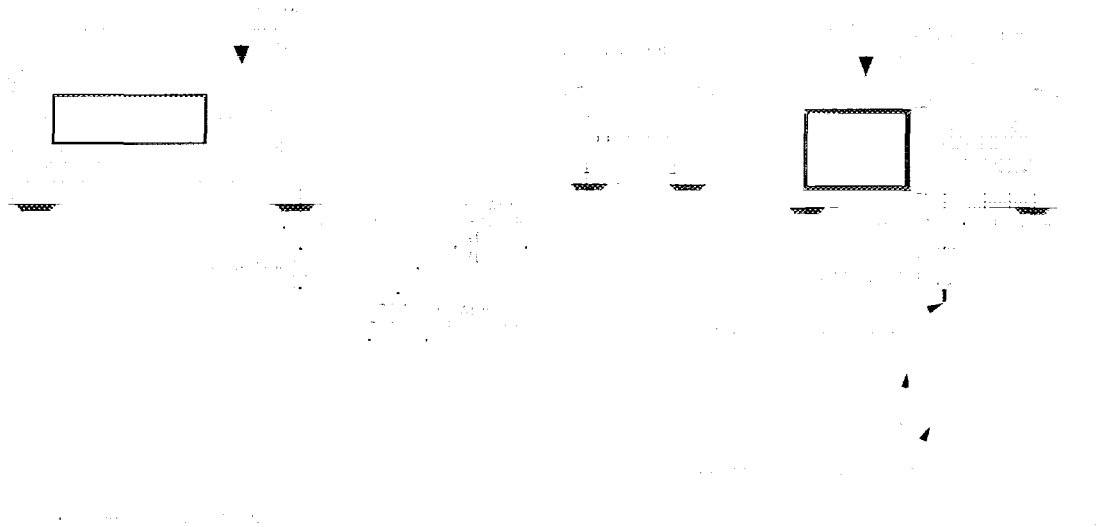
17. Receiver Magnitude Frequency Response (Option 002 Only)**Figure 6-35. Magnitude Frequency Response Test Setup**

- 2** Zero and calibrate the power meter. Set the power meter to measure dBm. Set the power meter calibration factor whenever necessary to compensate for power sensor frequency response. Refer to the power meter operating and service manual for more information on how to perform these tasks.
- 3** On the external source, press *PRESET, POWER LEVL, 0, dB(m), CW, 32, MHz*.
- 4** Write the power meter reading on the “Performance Test Record.” It should read approximately -10 dBm.
- 5** On the analyzer, press *PRESET, MENU, CW FREQ, 16, MHz* to set the analyzer’s internal source to 16 MHz.
- 6** Press *SYSTEM, HARMONIC MEAS, SECOND*.
- 7** Press *MARKER, MEAS, INPUT PORTS, A*. Write the marker 1 reading, which appears on the analyzer display, in the “Input A Value” column on the “Performance Test Record.”
- 8** Press *B*. Write the marker 1 reading, which appears on the analyzer display, in the “Input B Value” column on the “Performance Test Record.”
- 9** On the external source, press *48, MHz*. Record the power meter reading on the “Performance Test Record.”

17. Receiver Magnitude Frequency Response (Option 002 Only)

- 10** On the analyzer, press SYSTEM, *HARMONIC MEAS*, *THIRD*. Write the marker 1 reading in the “Input B Value” column on the “Performance Test Record.”
- 11** Press MEAS, *INPUT PORTS*, *A*. Write the marker 1 reading, which appears on the analyzer display, in the “Input A Value” column on the “Performance Test Record.”
- 12** On the analyzer, press SYSTEM, *HARMONIC MEAS*, *OFF*, MENU, *CWFREQ*, 31, M/ μ to set the analyzer to the next fundamental frequency.
- 13** On the external source, press 62, MHz. Record the power meter reading on the “Performance Test Record.”
- 14** On the analyzer, press SYSTEM, *HARMONIC MEAS*, *SECOND*. Write the marker 1 reading in the “Input A Value” column on the “Performance Test Record.”
- 15** Press MEAS, *INPUT PORTS*, *B*. Write the marker 1 reading, which appears on the analyzer display, in the “Input B Value” column on the “Performance Test Record.”
- 16** On the external source, press 93, MHz. Record the power meter reading on the “Performance Test Record.”
- 17** On the analyzer, press SYSTEM, *HARMONIC MEAS*, *THIRD*. Write the marker 1 reading in the “Input B Value” column on the “Performance Test Record.”
- 18** Press MEAS, *INPUT PORTS*, *A*. Write the marker 1 reading, which appears on the analyzer display, in the “Input A Value” column on the “Performance Test Record.”
- 19** Repeat Step 12 through Step 18 for the CW frequencies listed on the “Performance Test Record.”
- 20** For each measurement, calculate the difference between the measurement and the power meter level.
- 21** Write the calculation results in the “Performance Test Record.”
- 22** Compare the results with the specification.

Performance Test Records - Option 011

The following tables are to record the performance test records for each of the HP 8702D Option 011 tests.

Test 1. Source Frequency Range and Accuracy

CW Frequency (MHz)	Lower Limit (MHz)	Measured Value (MHz)	Upper Limit (MHz)	Measurement Uncertainty (MHz)
0.3	0.299 997	_____	0.300 003	± 0.000 000 360
5.0	4.999 950	_____	5.000 050	± 0.000 006
16.0	15.999 840	_____	16.000 160	± 0.000 019
31.0	30.999 690	_____	31.000 310	± 0.000 037
60.999 999	60.999 390	_____	61.000 610	± 0.000 073
121.0	120.998 790	_____	121.001 210	± 0.000 145
180.0	179.998 200	_____	180.001 800	± 0.000 216
310.0	309.995 900	_____	310.003 100	± 0.000 372
700.0	699.930 000	_____	700.007 000	± 0.000 840
1 300.0	1 299 987	_____	1 300 013	± 0.001 560
2 000.0	1 999 980	_____	2 000 020	± 0.002 400
3 000.0	2 999 970	_____	3 000 030	± 0.003 600
Option 006				
4.0	3.999 960	_____	4.000 040	± 0.004 800
5.0	4.999 950	_____	5.000 050	± 0.006 000
6.0	5.999 940	_____	6.000 060	± 0.007 200

Test 2. Source Power Range, Linearity, and Accuracy (Path Loss Calculations)

CW Frequency	Source Output Power Level (dBm)	First Value (dB)	Second Value (dB)	Path Loss (dB)
300 kHz	+10	_____	_____	_____
20 MHz	+10	_____	_____	_____
50 MHz	+10	_____	_____	_____
100 MHz	+10	_____	_____	_____
200 MHz	+10	_____	_____	_____
500 MHz	+10	_____	_____	_____
1 GHz	+10	_____	_____	_____
2 GHz	+10	_____	_____	_____
3 GHz	+10	_____	_____	_____
Option 006				
4 GHz	+10	_____	_____	_____
5 GHz	+10	_____	_____	_____
6 GHz	+10	_____	_____	_____

Performance Tests – Option 011
Performance Test Records - Option 011

Test 2. Source Power Range, Linearity, and Accuracy (Power Range and Power Linearity) (1 of 2)

Source Power Level (dBm)	Power Offset (dB)	Path Loss (dB)	Measured Value (dB)	Power Linearity (dB)	Specification (dB)	Measurement Uncertainty (dB)
CW Frequency = 300 kHz						
-5	+15	_____	_____	_____	± 0.25	± 0.15
-3	+13	_____	_____	_____	± 0.25	± 0.15
-1	+11	_____	_____	_____	± 0.25	± 0.15
+1	+9	_____	_____	_____	± 0.25	± 0.15
+3	+7	_____	_____	_____	± 0.25	± 0.15
+5	+5	_____	_____	_____	± 0.25	± 0.15
+7	+3	_____	_____	_____	± 0.25	± 0.15
+9	+1	_____	_____	_____	± 0.25	± 0.15
+11	-1	_____	_____	_____	± 0.25	± 0.15
+13	-3	_____	_____	_____	± 0.25	± 0.15
+15	-5	_____	_____	_____	± 0.5	± 0.15
+17	-7	_____	_____	_____	± 0.5	± 0.15
+20	-10	_____	_____	_____	± 0.5	± 0.15
CW Frequency = 3 GHz						
-5	+15	_____	_____	_____	± 0.25	± 0.15
-3	+13	_____	_____	_____	± 0.25	± 0.15
-1	+11	_____	_____	_____	± 0.25	± 0.15
+1	+9	_____	_____	_____	± 0.25	± 0.15
+3	+7	_____	_____	_____	± 0.25	± 0.15
+5	+5	_____	_____	_____	± 0.25	± 0.15
+7	+3	_____	_____	_____	± 0.25	± 0.15
+9	+1	_____	_____	_____	± 0.25	± 0.15
+11	-1	_____	_____	_____	± 0.25	± 0.15
+13	-3	_____	_____	_____	± 0.25	± 0.15

Test 2. Source Power Range, Linearity, and Accuracy (Power Range and Power Linearity) (2 of 2)

Source Power Level (dBm)	Power Offset (dB)	Path Loss (dB)	Measured Value (dB)	Power Linearity (dB)	Specification (dB)	Measurement Uncertainty (dB)
+ 15	- 5	_____	_____	_____	± 0.5	± 0.15
+ 17	- 7	_____	_____	_____	± 0.5	± 0.15
+ 20	- 10	_____	_____	_____	± 0.5	± 0.15
Option 006						
CW Frequency = 300 kHz						
+ 13	- 3	_____	_____	_____	± 0.5	± 0.15
+ 18	- 8	_____	_____	_____	± 0.5	± 0.15
CW Frequency = 3 GHz						
+ 13	- 3	_____	_____	_____	± 0.5	± 0.15
+ 18	- 8	_____	_____	_____	± 0.5	± 0.15
CW Frequency = 6 GHz						
- 5	+ 15	_____	_____	_____	± 0.25	± 0.15
- 3	+ 13	_____	_____	_____	± 0.25	± 0.15
- 1	+ 11	_____	_____	_____	± 0.25	± 0.15
+ 1	+ 9	_____	_____	_____	± 0.25	± 0.15
+ 3	+ 7	_____	_____	_____	± 0.25	± 0.15
+ 5	+ 5	_____	_____	_____	± 0.25	± 0.15
+ 7	+ 3	_____	_____	_____	± 0.25	± 0.15
+ 9	+ 1	_____	_____	_____	± 0.25	± 0.15
+ 11	- 1	_____	_____	_____	± 0.25	± 0.15
+ 13	- 3	_____	_____	_____	± 0.5	± 0.15
+ 15	- 5	_____	_____	_____	± 0.5	± 0.15
+ 18	- 8	_____	_____	_____	± 0.5	± 0.15

Performance Tests – Option 011
Performance Test Records - Option 011

Test 2. Source Power, Range, Linearity and Accuracy (Power Level Accuracy)

CW Frequency (MHz)	Path Loss (dB)	Calibrated Power Level (dB)	Measured Value (dB)	Power Level Accuracy (dB)	Spec. (dB)	Meas. Uncer. (dB)
Source Output Power Level = +10 dBm						
0.300	_____	_____	_____	_____	± 1.0	± 0.15
20.000	_____	_____	_____	_____	± 1.0	± 0.10
50.000	_____	_____	_____	_____	± 1.0	± 0.10
100.000	_____	_____	_____	_____	± 1.0	± 0.10
200.000	_____	_____	_____	_____	± 1.0	± 0.10
500.000	_____	_____	_____	_____	± 1.0	± 0.10
1 000.000	_____	_____	_____	_____	± 1.0	± 0.10
2 000.000	_____	_____	_____	_____	± 1.0	± 0.10
3 000.000	_____	_____	_____	_____	± 1.0	± 0.15
Option 006						
4 000.000	_____	_____	_____	_____	± 1.0	± 0.18
5 000.000	_____	_____	_____	_____	± 1.0	± 0.18
6 000.000	_____	_____	_____	_____	± 1.0	± 0.18

Test 3. Receiver Minimum R Channel Level

CW Frequency	Specification (dB)	Marker Value (dB)	Measurement Uncertainty (dB)
300 kHz	< -35	_____	± 1.0
3.29 MHz	< -35	_____	± 1.0
3.31 MHz	< -35	_____	± 1.0
15.90 MHz	< -35	_____	± 1.0
16.10 MHz	< -35	_____	± 1.0
30.90 MHz	< -35	_____	± 1.0
31.10 MHz	< -35	_____	± 1.0
1.6069 GHz	< -35	_____	± 1.0
1.6071 GHz	< -35	_____	± 1.0
3.000 GHz	< -35	_____	± 1.0
Option 006			
4.000 GHz	< -30	_____	± 3.0
5.000 GHz	< -30	_____	± 3.0
6.000 GHz	< -30	_____	± 3.0

Test 4. Receiver Minimum R Channel Level for External Source Mode

CW Frequency (MHz)	Frac-N VCO Lower Limit (MHz)	Frac-N VCO Upper Limit (MHz)	Measured Value (MHz)	Measurement Uncertainty
10	49.496	50.496	_____	N/A
20	37.620	38.380	_____	N/A
100	49.005	49.995	_____	N/A
1 000	36.630	37.370	_____	N/A
3 000	58.216	59.392	_____	N/A
Option 006				
4 000	39.198	39.990	_____	N/A
5 000	49.000	49.990	_____	N/A
6 000	58.802	59.990	_____	N/A

Test 5. Receiver Channel Noise Floor Level

Frequency Range	IF Bandwidth	Specification (dBm)	Calculated Value	Measurement Uncertainty
Receiver Channel A				
300 kHz – 3.0 GHz	3 kHz	– 90	_____	N/A
300 kHz – 3.0 GHz	10 Hz	– 110	_____	N/A
Receiver Channel B				
300 kHz – 3.0 GHz	10 Hz	– 110	_____	N/A
300 kHz – 3.0 GHz	3 kHz	– 90	_____	N/A
Option 006				
Receiver Channel A				
50 kHz – 3.0 GHz	3 kHz	– 90	_____	N/A
50 kHz – 3.0 GHz	10 Hz	– 110	_____	N/A
Receiver Channel B				
50 kHz – 3.0 GHz	10 Hz	– 110	_____	N/A
50 kHz – 3.0 GHz	3 kHz	– 90	_____	N/A
Receiver Channel B				
3.0 GHz – 6.0 GHz	3 kHz	– 85	_____	N/A
3.0 GHz – 6.0 GHz	10 Hz	– 105	_____	N/A
Receiver Channel A				
3.0 GHz – 6.0 GHz	10 Hz	– 105	_____	N/A
3.0 GHz – 6.0 GHz	3 kHz	– 85	_____	N/A

Performance Tests – Option 011
Performance Test Records - Option 011

Test 7. Receiver Magnitude Frequency Response

CW Frequency	Power Meter Reading	R Input Power	A Input Power	B Input Power	Greatest Difference	Spec. (dB)	Meas. Uncer. (dB)
Example	- 10.0	- 10.14	- 10.09	- 10.10	0.14	± 1	± 0.05
300 kHz	_____	_____	_____	_____	_____	± 1	± 0.05
5 MHz	_____	_____	_____	_____	_____	± 1	± 0.05
16 MHz	_____	_____	_____	_____	_____	± 1	± 0.05
31 MHz	_____	_____	_____	_____	_____	± 1	± 0.05
61 MHz	_____	_____	_____	_____	_____	± 1	± 0.05
121 MHz	_____	_____	_____	_____	_____	± 1	± 0.05
180 MHz	_____	_____	_____	_____	_____	± 1	± 0.05
310 MHz	_____	_____	_____	_____	_____	± 1	± 0.05
700 MHz	_____	_____	_____	_____	_____	± 1	± 0.05
1.5 GHz	_____	_____	_____	_____	_____	± 1	± 0.05
2.0 GHz	_____	_____	_____	_____	_____	± 1	± 0.05
2.5 GHz	_____	_____	_____	_____	_____	± 1	± 0.05
3.0 GHz	_____	_____	_____	_____	_____	± 1	± 0.05
Option 006							
3.5 GHz	_____	_____	_____	_____	_____	± 2	± 0.05
4.0 GHz	_____	_____	_____	_____	_____	± 2	± 0.05
4.5 GHz	_____	_____	_____	_____	_____	± 2	± 0.05
5.0 GHz	_____	_____	_____	_____	_____	± 2	± 0.05
5.5 GHz	_____	_____	_____	_____	_____	± 2	± 0.05
6.0 GHz	_____	_____	_____	_____	_____	± 2	± 0.05

Test 8. Receiver Phase Frequency Response

Frequency Range	Ratio	Specification	Measured Value	Measurement Uncertainty
300 kHz – 3 GHz	A/R	$\pm 3^\circ$	_____	$\pm 0.35^\circ$
300 kHz – 3 GHz	B/R	$\pm 3^\circ$	_____	$\pm 0.35^\circ$
300 kHz – 3 GHz	A/B	$\pm 3^\circ$	_____	$\pm 0.35^\circ$
Option 006				
3 GHz – 6 GHz	A/B	$\pm 10^\circ$	_____	$\pm 0.35^\circ$
3 GHz – 6 GHz	A/R	$\pm 10^\circ$	_____	$\pm 0.35^\circ$
3 GHz – 6 GHz	B/R	$\pm 10^\circ$	_____	$\pm 0.35^\circ$

Test 9. Receiver Input Crosstalk

Frequency Range	Specification (dB)	Marker Value	Measurement Uncertainty
R into A Crosstalk			
300 kHz – 1.0 GHz	– 100	_____	N/A
1.0 GHz – 3.0 GHz	– 90	_____	N/A
R into B Crosstalk			
300 kHz – 1.0 GHz	– 100	_____	N/A
1.0 GHz – 3.0 GHz	– 90	_____	N/A
B into A Crosstalk			
300 kHz – 1.0 GHz	– 100	_____	N/A
1.0 GHz – 3.0 GHz	– 90	_____	N/A
A into B Crosstalk			
300 kHz – 1.0 GHz	– 100	_____	N/A
1.0 GHz – 3.0 GHz	– 90	_____	N/A
Option 006			
R into A Crosstalk			
3.0 GHz – 4.5 GHz	– 82	_____	N/A
4.5 GHz – 6.0 GHz	– 75	_____	N/A
R into B Crosstalk			
3.0 GHz – 4.5 GHz	– 82	_____	N/A
4.5 GHz – 6.0 GHz	– 75	_____	N/A
B into A Crosstalk			
3.0 GHz – 4.5 GHz	– 82	_____	N/A
4.5 GHz – 6.0 GHz	– 75	_____	N/A
A into B Crosstalk			
3.0 GHz – 4.5 GHz	– 82	_____	N/A
4.5 GHz – 6.0 GHz	– 75	_____	N/A

Test 10. Receiver Trace Noise

CW Frequency (GHz)	Ratio	Measured Value	Specification (rms)	Measurement Uncertainty
3	A/R	_____	≤ 0.006 dB	N/A
3	B/R	_____	≤ 0.006 dB	N/A
3	A/B	_____	≤ 0.006 dB	N/A
3	A/B	_____	≤ 0.038°	N/A
3	B/R	_____	≤ 0.038°	N/A
3	A/R	_____	≤ 0.038°	N/A
Option 006				
6	A/R	_____	≤ 0.010 dB	N/A
6	B/R	_____	≤ 0.010 dB	N/A
6	A/B	_____	≤ 0.010 dB	N/A
6	A/B	_____	≤ 0.070°	N/A
6	B/R	_____	≤ 0.070°	N/A
6	A/R	_____	≤ 0.070°	N/A

Test 11. Receiver Input Impedance

Frequency Range	B Return Loss (A/R)	A Return Loss (B/R)	R Return Loss (A/B)	Specification (dB)	Measurement Uncertainty (dB)
2 MHz – 1.3 GHz	_____	_____	_____	≥ 23	± 1.5
1.3 GHz – 3 GHz	_____	_____	_____	≥ 20	± 1.0

Test 12. Receiver Magnitude Dynamic Accuracy (1 of 2)

Receiver Input Power (dB)	HP 8496A Setting (dB)	Receiver Channel A (dB)	HP 8902A (dB)	Magnitude Value (dB)	Spec. (dB)	Meas. Uncer. (dB)
Channel A						
- 10	0	_____	_____	_____	≤ 0.075	± 0.010
- 20	10	_____	_____	_____	≤ 0.059	± 0.020
- 30	20	_____	_____	_____	≤ 0.050	± 0.020
- 40	30	_____	_____	_____	≤ 0.050	± 0.040
- 50	40	_____	_____	_____	≤ 0.050	± 0.060
- 60	50	_____	_____	_____	≤ 0.058	± 0.080
- 70	60	_____	_____	_____	≤ 0.089	± 0.140
- 80	70	_____	_____	_____	≤ 0.240	± 0.160
- 90	80	_____	_____	_____	≤ 0.680	± 0.180
- 100	90	_____	_____	_____	≤ 1.950	± 0.200
- 110	100	_____	_____	_____	≤ 5.200	± 0.280
Channel B						
- 10	0	_____	_____	_____	≤ 0.075	± 0.010
- 20	10	_____	_____	_____	≤ 0.059	± 0.020
- 30	20	_____	_____	_____	≤ 0.050	± 0.020
- 40	30	_____	_____	_____	≤ 0.050	± 0.040
- 50	40	_____	_____	_____	≤ 0.050	± 0.060
- 60	50	_____	_____	_____	≤ 0.058	± 0.080
- 70	60	_____	_____	_____	≤ 0.089	± 0.140
- 80	70	_____	_____	_____	≤ 0.240	± 0.160
- 90	80	_____	_____	_____	≤ 0.680	± 0.180
- 100	90	_____	_____	_____	≤ 1.950	± 0.200

Test 12. Receiver Magnitude Dynamic Accuracy (2 of 2)

Receiver Input Power (dB)	HP 8496A Setting (dB)	Receiver Channel A (dB)	HP 8902A (dB)	Magnitude Value (dB)	Spec. (dB)	Meas. Uncer. (dB)
- 110 Channel R	100	_____	_____	_____	≤ 5.200	± 0.280
- 10	0	_____	_____	_____	≤ 0.075	± 0.010
- 20	10	_____	_____	_____	≤ 0.059	± 0.020
- 30	20	_____	_____	_____	≤ 0.050	± 0.020

Test 13. Receiver Phase Dynamic Accuracy (1 of 2)

Receiver Input Power (dB)	Magnitude Value (dB)	A	B	Calculated Value (degrees)	Spec. (degrees)	Mea. Uncer.
Channel A						
- 10	_____	_____	_____	_____	≤ 0.80	N/A
- 20	_____	_____	_____	_____	≤ 0.40	N/A
- 30	_____	_____	_____	_____	≤ 0.35	N/A
- 40	_____	_____	_____	_____	≤ 0.35	N/A
- 50	_____	_____	_____	_____	≤ 0.35	N/A
- 60	_____	_____	_____	_____	≤ 0.37	N/A
- 70	_____	_____	_____	_____	≤ 0.60	N/A
- 80	_____	_____	_____	_____	≤ 1.60	N/A
- 90	_____	_____	_____	_____	≤ 4.80	N/A
- 100	_____	_____	_____	_____	≤ 16.00	N/A
- 110	_____	_____	_____	_____	≤ 51.50	N/A
Channel B						
- 10	_____	_____	_____	_____	≤ 0.80	N/A
- 20	_____	_____	_____	_____	≤ 0.40	N/A
- 30	_____	_____	_____	_____	≤ 0.35	N/A
- 40	_____	_____	_____	_____	≤ 0.35	N/A
- 50	_____	_____	_____	_____	≤ 0.35	N/A
- 60	_____	_____	_____	_____	≤ 0.37	N/A
- 70	_____	_____	_____	_____	≤ 0.60	N/A
- 80	_____	_____	_____	_____	≤ 1.60	N/A
- 90	_____	_____	_____	_____	≤ 4.80	N/A
- 100	_____	_____	_____	_____	≤ 16.00	N/A

Test 13. Receiver Phase Dynamic Accuracy (2 of 2)

Receiver Input Power (dB)	Magnitude Value (dB)	A	B	Calculated Value (degrees)	Spec. (degrees)	Mea. Uncer.
-110	_____	_____	_____	_____	≤ 51.50	N/A
Channel R						
-10	_____	_____	_____	_____	≤ 0.80	N/A
-20	_____	_____	_____	_____	≤ 0.40	N/A
-30	_____	_____	_____	_____	≤ 0.35	N/A

Test 14. Receiver Magnitude Compression (1 of 2)

CW Frequency	Start Power (dBm)	Stop Power (dBm)	Measured Value (dB)	Specification (dB)	Measurement Uncertainty
Channel A					
50 MHz	_____	_____	_____	≤ 0.32	N/A
1 GHz	_____	_____	_____	≤ 0.32	N/A
2 GHz	_____	_____	_____	≤ 0.32	N/A
3 GHz	_____	_____	_____	≤ 0.32	N/A
Channel B					
50 MHz	_____	_____	_____	≤ 0.32	N/A
1 GHz	_____	_____	_____	≤ 0.32	N/A
2 GHz	_____	_____	_____	≤ 0.32	N/A
3 GHz	_____	_____	_____	≤ 0.32	N/A
Channel R					
50 MHz	_____	_____	_____	≤ 0.32	N/A
1 GHz	_____	_____	_____	≤ 0.32	N/A
2 GHz	_____	_____	_____	≤ 0.32	N/A
3 GHz	_____	_____	_____	≤ 0.32	N/A
Option 006					
Channel A					
4 GHz	_____	_____	_____	≤ 0.32	N/A
5 GHz	_____	_____	_____	≤ 0.32	N/A
6 GHz	_____	_____	_____	≤ 0.32	N/A
Channel B					
4 GHz	_____	_____	_____	≤ 0.32	N/A

Test 14. Receiver Magnitude Compression (2 of 2)

CW Frequency	Start Power (dBm)	Stop Power (dBm)	Measured Value (dB)	Specification (dB)	Measurement Uncertainty
5 GHz	_____	_____	_____	≤ 0.32	N/A
6 GHz	_____	_____	_____	≤ 0.32	N/A
Channel R					
4 GHz	_____	_____	_____	≤ 0.32	N/A
5 GHz	_____	_____	_____	≤ 0.32	N/A
6 GHz	_____	_____	_____	≤ 0.32	N/A

Test 15. Receiver Phase Compression (1 of 2)

CW Frequency	Start Power (dBm)	Stop Power (dBm)	Measured Value (degrees)	Specification (degrees)	Measurement Uncertainty
Channel A					
50 MHz	_____	_____	_____	≤ 5.2	N/A
1 GHz	_____	_____	_____	≤ 5.2	N/A
2 GHz	_____	_____	_____	≤ 5.2	N/A
3 GHz	_____	_____	_____	≤ 5.2	N/A
Channel B					
50 MHz	_____	_____	_____	≤ 5.2	N/A
1 GHz	_____	_____	_____	≤ 5.2	N/A
2 GHz	_____	_____	_____	≤ 5.2	N/A
3 GHz	_____	_____	_____	≤ 5.2	N/A
Channel R					
50 MHz	_____	_____	_____	≤ 5.2	N/A
1 GHz	_____	_____	_____	≤ 5.2	N/A
2 GHz	_____	_____	_____	≤ 5.2	N/A
3 GHz	_____	_____	_____	≤ 5.2	N/A
Option 006					
Channel A					
4 GHz	_____	_____	_____	≤ 5.2	N/A
5 GHz	_____	_____	_____	≤ 5.2	N/A
6 GHz	_____	_____	_____	≤ 5.2	N/A
Channel B					

Test 15. Receiver Phase Compression (2 of 2)

CW Frequency	Start Power (dBm)	Stop Power (dBm)	Measured Value (degrees)	Specification (degrees)	Measurement Uncertainty
4 GHz	_____	_____	_____	≤ 5.2	N/A
5 GHz	_____	_____	_____	≤ 5.2	N/A
6 GHz	_____	_____	_____	≤ 5.2	N/A
Channel R					
4 GHz	_____	_____	_____	≤ 5.2	N/A
5 GHz	_____	_____	_____	≤ 5.2	N/A
6 GHz	_____	_____	_____	≤ 5.2	N/A

Test 16. Source and Receiver Harmonics (Option 002 Only) (1 of 2)

Test Description	Harmonic	Specification (dBc)	Measurement Value	Measurement Uncertainty (dB)
Source Harmonics				
1.5	2nd	< - 25	_____	± 1
1.0	3rd	< - 25	_____	± 1
Source and Receiver Harmonics				
1.5	A: 2nd	< - 15	_____	± 1
1.0	A: 3rd	< - 30	_____	± 1
1.5	B: 2nd	< - 15	_____	± 1
1.0	B: 3rd	< - 30	_____	± 1
Receiver Harmonics				
1.5	B: 2nd	< - 15	_____	± 1
1.0	B: 3rd	< - 30	_____	± 1
1.5	A: 2nd	< - 15	_____	± 1
1.0	A: 3rd	< - 30	_____	± 1
Option 006				
Source Harmonics				
3	2nd	< - 25	_____	± 1
2	3rd	< - 25	_____	± 1
Source and Receiver Harmonics				
3	A: 2nd	< - 15	_____	± 1
2	A: 3rd	< - 30	_____	± 1
3	B: 2nd	< - 15	_____	± 1
2	B: 3rd	< - 30	_____	± 1

Performance Test Records - Option 011

Test 16. Source and Receiver Harmonics (Option 002 Only) (2 of 2)

Test Description	Harmonic	Specification (dBc)	Measurement Value	Measurement Uncertainty (dB)
Receiver Harmonics				
3	B: 2nd	< - 15	_____	± 1
2	B: 3rd	< - 30	_____	± 1
3	A: 2nd	< - 15	_____	± 1
2	A: 3rd	< - 30	_____	± 1

Test 17. Receiver Magnitude Response (Option 002 Only)

Analyzer Frequency	Ext. Source Frequency	Power Meter Value	Input A Value	Input B Value	Max. Diff. Spec	Spec. (dB)	Meas. Uncer. (dB)
16 MHz	32 MHz	_____	_____	_____	_____	± 1	± 0.05
16 MHz	48 MHz	_____	_____	_____	_____	± 1	± 0.05
31 MHz	62 MHz	_____	_____	_____	_____	± 1	± 0.05
31 MHz	93 MHz	_____	_____	_____	_____	± 1	± 0.05
61 MHz	122 MHz	_____	_____	_____	_____	± 1	± 0.05
61 MHz	183 MHz	_____	_____	_____	_____	± 1	± 0.05
121 MHz	242 MHz	_____	_____	_____	_____	± 1	± 0.05
121 MHz	363 MHz	_____	_____	_____	_____	± 1	± 0.05
180 MHz	360 MHz	_____	_____	_____	_____	± 1	± 0.05
180 MHz	540 MHz	_____	_____	_____	_____	± 1	± 0.05
310 MHz	620 MHz	_____	_____	_____	_____	± 1	± 0.05
310 MHz	930 MHz	_____	_____	_____	_____	± 1	± 0.05
700 MHz	1.4 GHz	_____	_____	_____	_____	± 1	± 0.05
700 MHz	2.1 GHz	_____	_____	_____	_____	± 1	± 0.05
1 GHz	2 GHz	_____	_____	_____	_____	± 1	± 0.05
1 GHz	3 GHz	_____	_____	_____	_____	± 1	± 0.05
1.5 GHz	3 GHz	_____	_____	_____	_____	± 1	± 0.05
Option 006							
2 GHz	4 GHz	_____	_____	_____	_____	± 2	± 0.05
2 GHz	6 GHz	_____	_____	_____	_____	± 2	± 0.05
3 GHz	6 GHz	_____	_____	_____	_____	± 2	± 0.05



If You Encounter a Problem

If You Encounter a Problem

If you have difficulty when installing or using the HP 8702D, check the following list of commonly encountered problems and troubleshooting procedures.

Contact the nearest Hewlett-Packard office for service, if necessary. A list of Hewlett-Packard sales and service offices is provided at the end of this book.

What you'll find in this chapter

- If the display does not light 7-4
- If the fan does not run 7-5
- If data entry keys don't respond 7-6
- If there is no RF signal 7-7
- Returning the Instrument for Service 7-8
 - Preparing the instrument for shipping 7-9
- Hewlett-Packard Sales and Service Offices 7-11

If the display does not light

- ❑ Check that the power cord is fully seated in both the main power receptacle and the HP 8702D's power module.
- ❑ Check that the AC line voltage selector switch is in the appropriate position (230V/115V) for your available power supply.
- ❑ Check that the HP 8702D's AC line fuse is not open.

Refer to Figure 7-1 to remove the fuse from the power module. Use an ohmmeter to check the fuse. The 3A, 250V fuse is HP part number 2110-0780.

WARNING

The power cord is connected to internal capacitors that may remain live for 10 seconds after you disconnect the cord from the power supply.

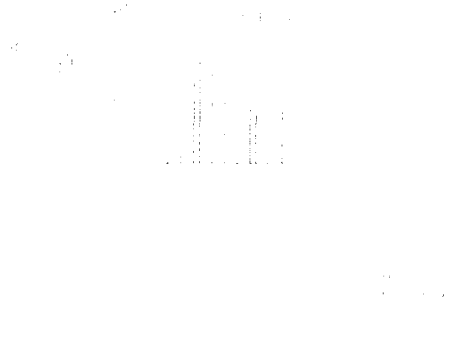

Figure 7-1. Line Fuse Removal and Replacement

WARNING

For continued protection against fire hazard, replace the fuse with the same type and rating.

If the fan does not run

- 1** Switch the LINE power switch to the off position.
- 2** Check that the fan blades are not jammed or obstructed.

If data entry keys don't respond

- ❑ Check that the "entry off" function is not enabled.
The "entry off" is enabled after you press the ENTRY OFF key. To return to normal entry mode, press any function key that has a numeric parameter associated with it. For example, START.
- ❑ Check that none of the keys are mechanically stuck.
- ❑ Check that the selected key is designed to accept data.
For example, SCALE REF accepts data, but SYSTEM does not.
- ❑ Ensure that you are not attempting to enter a value that is greater than or less than its limit.
- ❑ Check that the front panel "R" HP-IB STATUS light is *not* illuminated.
If the "R" HP-IB STATUS light is illuminated, a test sequence may be running, or a connected computer controller may be sending commands or instructions to, or receiving data from, the instrument. Press LOCAL if you want to return to local control.

If there is no RF signal

- Check that the signal at the test ports is switched on.
 - a Press MENU, *POWER*, *SOURCE PWR* until *ON* appears on the *SOURCE PWR* softkey label.
 - b Press MENU, *POWER*, *POWER TRIP on OFF* until *OFF* appears on the *POWER TRIP* softkey label.
- If you are applying external modulation (AM) to the HP 8702D, check the external modulating signal or external gate/trigger signals for problems.

CAUTION

If the error message: CAUTION: OVERLOAD ON INPUT X, POWER REDUCED appears on the display, too much source power is being applied at the input. In such a case, the input power will need to be reduced before the source power will remain on.

- Look for phase-lock error messages and then contact your nearest Hewlett-Packard office for service. A list of Hewlett-Packard Sales and Service offices is provided at the end of this book.

Returning the Instrument for Service

The instructions in this section show you how to properly package the instrument for return to a Hewlett-Packard service office. For a list of offices, refer to "Hewlett-Packard Sales and Service Offices" on page 7-11.

If the instrument is still under warranty or is covered by an HP maintenance contract, it will be repaired under the terms of the warranty or contract (the warranty is at the front of this manual). If the instrument is no longer under warranty or is not covered by an HP maintenance plan, Hewlett-Packard will notify you of the cost of the repair after examining the unit.

When an instrument is returned to a Hewlett-Packard service office for servicing, it must be adequately packaged and have a complete description of the failure symptoms attached.

When describing the failure, please be as specific as possible about the nature of the problem. Include copies of additional failure information (such as instrument failure settings, data related to instrument failure, and error messages) along with the instrument being returned.

Please notify the service office before returning your instrument for service. Any special arrangements for the instrument can be discussed at this time. This will help the HP service office repair and return your instrument as quickly as possible.

Preparing the instrument for shipping

- 1** Write a complete description of the failure and attach it to the instrument. Include any specific performance details related to the problem. The following information should be returned with the instrument.
 - Type of service required.
 - Date instrument was returned for repair.
 - Description of the problem:
 - Whether problem is constant or intermittent.
 - Whether instrument is temperature-sensitive.
 - Whether instrument is vibration-sensitive.
 - Instrument settings required to reproduce the problem.
 - Performance data.
 - Company name and return address.
 - Name and phone number of technical contact person.
 - Model number of returned instrument.
 - Full serial number of returned instrument.
 - List of any accessories returned with instrument.
- 2** Cover all front or rear-panel connectors that were originally covered when you first received the instrument.

CAUTION

Cover electrical connectors to protect sensitive components from electrostatic damage. Cover optical connectors to protect them from damage due to physical contact or dust.

CAUTION

Instrument damage can result from using packaging materials other than the original materials. Never use styrene pellets as packaging material. They do not adequately cushion the instrument or prevent it from shifting in the carton. They may also cause instrument damage by generating static electricity.

- 3** Pack the instrument in the original shipping containers. Original materials are available through any Hewlett-Packard office. Or, use the following guidelines:
 - Wrap the instrument in antistatic plastic to reduce the possibility of damage caused by electrostatic discharge.
 - For instruments weighing less than 54 kg (120 lb), use a double-walled, corrugated cardboard carton of 159 kg (350 lb) test strength.
 - The carton must be large enough to allow approximately 7 cm (3 inches) on all sides of the instrument for packing material, and strong enough to accom-

Returning the Instrument for Service

moderate the weight of the instrument.

- Surround the equipment with approximately 7 cm (3 inches) of packing material, to protect the instrument and prevent it from moving in the carton. If packing foam is not available, the best alternative is S.D-240 Air Cap™ from Scaled Air Corporation (Commerce, California 90001). Air Cap looks like a plastic sheet filled with air bubbles. Use the pink (antistatic) Air Cap™ to reduce static electricity. Wrapping the instrument several times in this material will protect the instrument and prevent it from moving in the carton.
- 4 Seal the carton with strong nylon adhesive tape.
 - 5 Mark the carton "FRAGILE, HANDLE WITH CARE".
 - 6 Retain copies of all shipping papers.

Hewlett-Packard Sales and Service Offices

Hewlett-Packard Sales and Service Offices (1 of 2)

U.S. FIELD OPERATIONS		
Headquarters Hewlett-Packard Company 19320 Pruneridge Avenue Cupertino, CA 95014 U.S.A. (800) 752-0900	California, Northern Hewlett-Packard Company 301 East Evelyn Mountain View, CA 94041 (415) 694-2000	California, Southern Hewlett-Packard Company 1421 South Manhattan Ave. Fullerton, CA 92631 (714) 999-6700
Colorado Hewlett-Packard Company 24 Inverness Place, East Englewood, CO 80112 (303) 649-5000	Georgia Hewlett-Packard Company 2000 South Park Place Atlanta, GA 30339 (404) 955-1500	Illinois Hewlett-Packard Company 5201 Tollview Drive Rolling Meadows, IL 60008 (708) 342-2000
New Jersey Hewlett-Packard Company 120 West Century Road Paramus, NJ 07653 (201) 586-5400	Texas Hewlett-Packard Company 930 East Campbell Road Richardson, TX 75081 (214) 231-6101	
EUROPEAN FIELD OPERATIONS		
Headquarters Hewlett-Packard S.A. 150, Route du Nant-d'Avril 1217 Meyrin 2/Geneva Switzerland (41 22) 780.8111	France Hewlett-Packard France 1 Avenue Du Canada Zone D'Activite De Courtaboeuf F-91947 Les Ulis Cedex France (33 1) 69 82 60 60	Germany Hewlett-Packard GmbH Hewlett-Packard Strasse 61352 Bad Homburg Germany (+49 6172) 16-0
Great Britain Hewlett-Packard Ltd. Eskdale Road, Winnersh Triangle Wokingham, Berkshire RG11 5DZ		

Hewlett-Packard Sales and Service Offices

Hewlett-Packard Sales and Service Offices (2 of 2)

INTERCON FIELD OPERATIONS		
<p>Headquarters Hewlett-Packard Company 3495 Deer Creek Rd. Palo Alto, California 94304-1316 (415) 857-5027</p>	<p>Australia Hewlett-Packard Australia Ltd. 31-41 Joseph Street Blackburn, Victoria 3130 (61 3) 895-2895</p>	<p>Canada Hewlett-Packard Ltd. 17500 South Service Road Trans-Canada Highway Kirkland, Quebec H9J 2X8 Canada (514) 697-4232</p>
<p>China China Hewlett-Packard Company 38 Bei San Huan X1 Road Shuang Yu Shu Hai Dian District Beijing, China (86 1) 256-6888</p>	<p>Japan Yokogawa-Hewlett-Packard Ltd. 1-27-15 Yabe, Sagami-hara Kanagawa 229, Japan (81 427) 59-1311</p>	<p>Singapore Hewlett-Packard Singapore Ltd. Pte. Ltd. Alexandra P.O. Box 87 Singapore 9115 (65) 271-9444</p>
<p>Taiwan Hewlett-Packard Taiwan 8th Floor, H-P Building 337 Fu Hsing North Road Taipei, Taiwan (886 2) 712-0404</p>		

Index

A

accuracy and range of frequency, 4-4
accuracy and range of frequency (Option 011),
6-4
accuracy of power test, 4-8

B

backup disk, 1-27

C

cabinet, cleaning, 1-2
calibration coefficients test, 4-39
care
 of cabinet, 1-2
checking the operation, 1-17
cleaning
 cabinet, 1-2
clock, setting, 1-16
connecting a plotter, 1-13, 1-15
connecting a printer, 1-13, 1-14
copying the EEPROM disk, 1-27

D

damaged shipment, 1-4
disk, backup, 1-27

E

EEPROM disk, copying, 1-27
equipment
 calibration coefficients, 4-39
 external source mode frequency range, 4-6
 minimum R channel level, 4-14, 6-12, 6-15
 source frequency range and accuracy test,
 6-4
 system trace noise (with option 006), 4-48
 system trace noise (without option 006),
 4-46, 6-38
 test port crosstalk, 4-34, 6-32
 test port frequency range and accuracy test,
 4-4
 test port input frequency response, 4-23,
 6-25
 test port input impedance, 4-51, 6-40
 test port input noise floor level, 4-19

 test port output power accuracy, 4-8
 test port output power range and linearity,
 4-11, 6-6
 test port receiver magnitude compression,
 4-65, 6-55
 test port receiver magnitude dynamic accu-
 racy, 4-55, 6-45
 test port receiver phase compression, 4-68,
 6-63
 test port receiver phase dynamic accuracy,
 4-63, 6-53
ESD (electrostatic discharge)
 reducing damage caused by ESD, 1-6
 static-safe work station, 1-6
external source mode frequency range test,
4-6

F

fiber optics
 connectors, covering, 7-9
frequency range and accuracy test, 4-4, 6-4
frequency range for external source mode, 4-6
frequency response test, 4-23, 6-25
fuse, 1-8

H

how to
 calibration coefficients, 4-39
 source frequency range and accuracy, 6-4
 system trace noise (with option 006), 4-48
 system trace noise (without option 006),
 4-46, 6-38
 test external source mode frequency range,
 4-6
 test frequency range and accuracy, 4-4, 6-4
 test minimum R channel level, 4-14, 6-12,
 6-15
 test port crosstalk, 4-34, 6-32
 test port input frequency response, 4-23,
 6-25
 test port input impedance, 4-51, 6-40
 test port input noise floor level, 4-19
 test port output frequency range and accu-
 racy, 4-4
 test port output power accuracy, 4-8
 test port output power range and linearity,

- 4-11, 6-6
 - test port receiver magnitude compression, 4-65, 6-55
 - test port receiver magnitude dynamic accuracy, 4-55, 6-45
 - test port receiver phase compression, 4-68, 6-63
 - test port receiver phase dynamic accuracy, 4-63, 6-53
 - HP offices, 7-11
 - HP-IB
 - interface, 1-13
- I**
- IEC Publication 1010, iv
 - inspecting
 - instrument, 1-4
 - installing, 1-2
 - instrument
 - returning for service, 7-8
 - interface
 - printer, 1-13
- L**
- LINE key, 1-12
 - linearity and range of power test, 4-11, 6-6
 - line-power
 - cable, 1-10
 - input connector, 1-8
 - LOCAL key, 1-13
- M**
- minimum R channel level test, 4-14, 6-12, 6-15
- N**
- noise floor level test, 4-19
- O**
- operation
 - checking, 1-17
- P**
- packaging for shipment, 7-9
 - parallel
 - interface, 1-13
 - performance test records, 4-81, 6-78
 - performance tests
 - calibration coefficients, 4-39
 - external source mode frequency range, 4-6
 - minimum R channel level, 4-14, 6-12, 6-15
 - receiver minimum R channel level for external source, 6-6
 - source frequency range and accuracy, 6-4
 - system trace noise (with option 006), 4-48
 - system trace noise (without option 006), 4-46, 6-38
 - test port crosstalk, 4-34, 6-32
 - test port input frequency response, 4-23, 6-25
 - test port input impedance, 4-51, 6-40
 - test port input noise Floor level, 4-19
 - test port output frequency range and accuracy, 4-4
 - test port output power accuracy, 4-8
 - test port output power range and linearity, 4-11
 - test port receiver magnitude compression, 4-65, 6-55
 - test port receiver magnitude dynamic accuracy, 4-55, 6-45
 - test port receiver phase compression, 4-68, 6-63
 - test port receiver phase dynamic accuracy, 4-63, 6-53
 - plotter
 - connecting, 1-13, 1-15
 - plotter type, 1-15
 - port output power accuracy test, 4-8
 - power accuracy test, 4-8
 - power range and linearity test, 4-11, 6-6
 - printer
 - connecting, 1-13, 1-14
 - interface, 1-13
 - printer type, 1-14
 - problems, data entry
 - controls do not respond, 7-6
 - problems, power-up
 - display lights, but fan does not start, 1-8, 7-4

problems, RF output
no RF signal at either PORT 1 or PORT 2, 7-7
procedures
calibration coefficients, 4-39
external source mode frequency range, 4-6
minimum R channel level, 4-14, 6-12, 6-15
source frequency range and accuracy, 6-4
system trace noise (with option 006), 4-48
system trace noise (without option 006),
4-46, 6-38
test port crosstalk, 4-34, 6-32
test port input frequency response, 4-23,
6-25
test port input impedance, 4-51, 6-40
test port input noise floor level, 4-19
test port output frequency range and accu-
racy, 4-4
test port output power accuracy, 4-8
test port output power range and linearity,
4-11, 6-6
test port receiver magnitude compression,
4-65, 6-55
test port receiver magnitude dynamic accu-
racy, 4-55, 6-45
test port receiver phase compression, 4-68,
6-63
test port receiver phase dynamic accuracy,
4-63, 6-53

R

R channel level, 4-14, 6-12, 6-15
rack mounting requirements, 1-2
range and accuracy of frequency, 4-4, 6-4
record test performance, 4-81, 6-78
returning for service, 7-8

S

safety
symbols, iii
sales and service offices, 7-11
serial
interface, 1-13
serial number instrument, 1-4
service, 7-8
returning for, 7-8
sales and service offices, 7-11

setting the clock, 1-16
setup
external source mode frequency range, 4-6
manual system verification, 3-3
minimum R channel level, 4-14, 6-12, 6-15
mismatch device verification, 2-9
mismatch device verification (manual
mode), 3-9
mismatch device verification (Option 011),
5-13, 5-22
source frequency range and accuracy test,
6-4
test port frequency range and accuracy test,
4-5
test port input noise floor level, 4-19
test port output power accuracy, 4-9
test port output power range and linearity,
4-12, 6-8
transmission calibration, 2-6
transmission calibration (Option 011), 5-8,
5-18
shipping
damage, 1-4
procedure, 7-9
source frequency range and accuracy test, 6-4
source mode frequency range, 4-6
specifications
calibration coefficients, 4-39
external source mode frequency range, 4-6
minimum R channel level, 4-14, 6-12, 6-15
source frequency range and accuracy, 6-4
system trace noise (with option 006), 4-48
system trace noise (without option 006),
4-46, 6-38
test port crosstalk, 4-34, 6-32
test port input frequency response, 4-23,
6-25
test port input impedance, 4-51, 6-40
test port input noise floor level, 4-19
test port output frequency range and accu-
racy, 4-4
test port output power accuracy, 4-8
test port output power range and linearity,
4-11, 6-6
test port receiver magnitude compression,
4-65, 6-55
test port receiver magnitude dynamic accu-
racy, 4-55, 6-45

test port receiver phase compression, 4-68, 6-63
test port receiver phase dynamic accuracy, 4-63, 6-53
system trace noise test (with option 006), 4-48
system trace noise test (without option 006), 4-46, 6-38

T

test port crosstalk test, 4-34, 6-32
test port input impedance test, 4-51, 6-40
test port output frequency range and accuracy test, 4-4
test port output power accuracy test, 4-8
test port output power range and linearity test, 4-11, 6-6
test port receiver magnitude compression test, 4-65, 6-55
test port receiver magnitude dynamic accuracy test, 4-55, 6-45
test port receiver phase compression test, 4-68, 6-63
test port receiver phase dynamic accuracy test, 4-63, 6-53
test records, 4-81, 6-78
tests
 calibration coefficients, 4-39
 external source mode frequency range, 4-6
 minimum R channel level, 4-14, 6-12, 6-15
 source frequency range and accuracy, 6-4
 system trace noise (with option 006), 4-48
 system trace noise (without option 006), 4-46, 6-38
 test port crosstalk, 4-34, 6-32
 test port input frequency response, 4-23, 6-25
 test port input impedance, 4-51, 6-40
 test port input noise floor level, 4-19
 test port output frequency range and accuracy, 4-4
 test port output power accuracy, 4-8
 test port output power range and linearity, 4-11, 6-6
 test port receiver magnitude compression, 4-65, 6-55
 test port receiver magnitude dynamic accuracy, 4-55, 6-45

test port receiver phase compression, 4-68, 6-63
test port receiver phase dynamic accuracy, 4-63, 6-53
time stamp, 1-16
troubleshooting, 1-12

V

ventilation requirements, 1-2